

# R&S® DST200

## RF Diagnostic Chamber

Accurate radiated testing  
of wireless devices from  
400 MHz to 18 GHz



# R&S®DST200 RF Diagnostic Chamber At a glance

The R&S®DST200 RF diagnostic chamber is the ideal environment for RF analysis during development. It supports a wide range of radiated test applications for wireless devices and fits on any R&D lab bench, where it can be used at all times during the product design and optimization phase. The R&S®DST200 effectively assists in achieving high first-time pass rates during final type approval, which saves time and money.

High-quality wireless devices have to pass special radiated tests such as desense and coexistence tests to ensure operation without self-interference. Verifying over-the-air (OTA) performance and measuring radiated spurious emissions (RSE) are also mandatory.

The R&S®DST200 provides support for the radiated tests that are required in R&D, quality assurance, production and service. Compared with applications using large EMC anechoic chambers, test setups with the R&S®DST200 are compact and easy to use and generate consistent, comparable results.

## Key facts

- Anechoic RF chamber with highly effective shielding > 110 dB for interference-free testing in unshielded environments
- Wide frequency range from 400 MHz to 18 GHz covering all important wireless standards
- High reproducibility of measurements due to excellent field uniformity at location of equipment under test (EUT)
- Compact dimensions suitable for any lab environment
- Unique mechanical design provides long-term stability and maintains high shielding effectiveness
- Simple and effective front door locking mechanism without pneumatic components
- Automated 3D positioner for OTA and RSE precompliance measurements

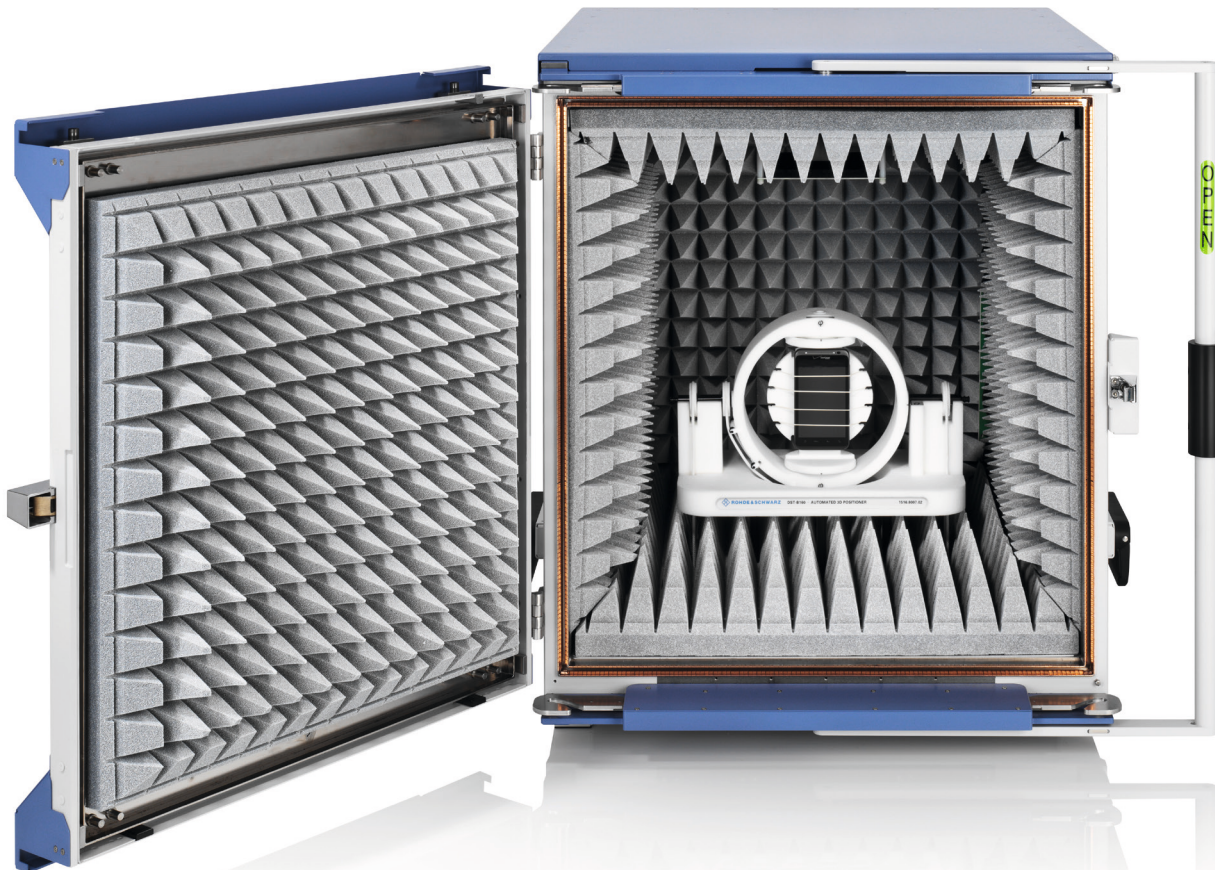

# R&S®DST200

## RF Diagnostic Chamber

### Benefits and key features

#### Shorter product development process ensures faster time to market

- ▮ Low total cost of ownership
  - ▮ Compact dimensions suitable for any R&D lab
- ▷ [page 4](#)

#### Future-oriented design

- ▮ Multiple feedthrough panels – functional test interfaces
  - ▮ Easy integration of RF preamplifiers and RF circuits
  - ▮ Exchangeable test antenna
- ▷ [page 5](#)

#### High measurement accuracy and repeatability

- ▮ Outstanding RF characteristics
  - ▮ High field uniformity for variable EUT positions
  - ▮ Manual 3D positioner
  - ▮ Simple and effective front door locking mechanism
- ▷ [page 6](#)

#### Broadband test and communications antennas

- ▮ Cross-polarized Vivaldi test antenna
  - ▮ Circular-polarized test antenna
  - ▮ Test antenna kit – for tailored applications
  - ▮ Communications antennas
- ▷ [page 8](#)

#### Automated 3D positioner for OTA and RSE measurements

- ▮ R&S®DST-B160 automated 3D positioner
  - ▮ R&S®DST-B165 large automated 3D positioner
- ▷ [page 10](#)

#### Excellent correlation with results of larger OTA and EMC test chambers

- ▮ Correlation of results obtained in different test chambers
  - ▮ Individual calibration of the R&S®DST200 RF diagnostic chamber
- ▷ [page 12](#)

#### Automated measurements with ready-to-use test templates

- ▮ Radiated measurements at a mouse click
  - ▮ Documenting results made easy
- ▷ [page 14](#)

#### Why are radiated tests vital?

Modern smartphones integrate complex technologies into the smallest possible space. Their RF section contains multistandard cellular and wireless modules such as Bluetooth®, WLAN and GPS, as well as several integrated antennas. The display, camera, keypad and touchscreen provide the interface to the user.

This combination of complex functional blocks has to be carefully harmonized to create a perfectly functioning design. At an early stage in the development process, various radiated tests are conducted under free-space conditions to help achieve compliance with the required specifications:

- ▮ Receiver sensitivity tests reveal self-interference (desense) effects in the design and also verify correct operation of multiple radio services by means of coexistence tests
- ▮ Spatial tests of the total radiated power (TRP) and the total isotropic sensitivity (TIS) verify the over-the-air (OTA) antenna performance and ensure high quality of service at the edge of network cells
- ▮ Radiated spurious emissions (RSE) measurements verify that the EUT does not interfere with other radio services

#### What is desense?

The term desense refers to the desensitization of receiver performance. Desense is caused by interference between components resulting, for example, from oscillator harmonics, internal noise on the printed board and antenna crosstalk.

The result is a lower quality of service, e.g. dropped calls on specific channels at the edge of network cells.

#### What is meant by coexistence of radio services?

Coexistence means the simultaneous operation of multiple radio services in a wireless device. Each service can degrade receiver performance for the other services. For example, harmonics of a GSM transmit channel can disrupt a WLAN receive channel. This can cause the quality of service to deteriorate. Disrupted data packets have to be repeated, which lowers data throughput.

# Shorter product development process ensures faster time to market

## Low total cost of ownership

The design of cutting-edge wireless devices such as multi-standard smartphones requires extensive testing and verification. When launching new products, manufacturers are constantly under pressure to maintain or even expand their market position.

This requires a well-planned development process in order to achieve a first-time pass during wireless device type approval. Radiated tests are essential during development and must be conducted using special test tools and environments. To minimize the total cost of ownership, test tools and environments should be flexible enough to be deployed at different sites.

## Compact dimensions suitable for any R&D lab

Thanks to its compact dimensions, the R&S®DST200 fits on any lab bench. Developers no longer depend on large, external EMC test chambers to test and optimize products in the design phase and can thus avoid a bottleneck, since these chambers are usually booked long in advance.

Radiated testing during development ensures faster time to market, reduces costs and keeps the product launch on schedule.

### Test tools and environments must be harmonized to meet all requirements from R&D to type approval

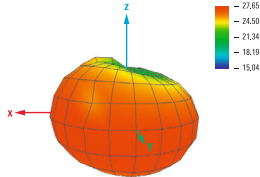
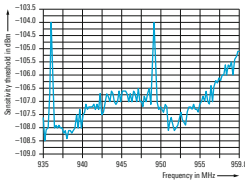

R&S®DST200

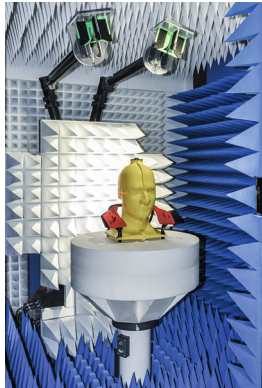

WPTC-XS wireless performance test chamber



5 m OTA test chamber

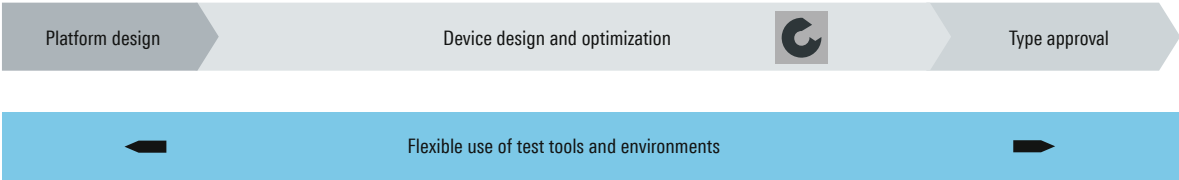

First-time pass!



# Future-oriented design

With a frequency range from 400 MHz to 18 GHz, the R&S®DST200 can be used for testing all common wireless standards. Its modular design with accessible top and bottom compartments provides flexibility for installing additional hardware to accommodate specific test requirements. This concept also ensures that the field characteristics in the measurement region around the EUT remain unaffected.

## Multiple feedthrough panels – functional test interfaces

Many tests require access to the EUT's external interfaces. Typical tests cover charger functionality, operation of the test mode interface, data throughput, and switching on or off of components such as the display or camera.

The bottom compartment provides three locations for installing various RF feedthroughs and filtered lines:

- 9-pin D-Sub lowpass filter and two fiber-optic feedthrough connectors (R&S®DST-B101 option)
- Two N feedthrough connectors (R&S®DST-B102 option)
- USB 2.0 lowpass filter (R&S®DST-B103 option)
- AC lowpass filter (R&S®DST-B104 option)

## Easy integration of RF preamplifiers and RF circuits

An accessible compartment at the top of the R&S®DST200 allows the integration of RF circuits between the test antenna and the test equipment. For example, preamplifiers can be used to extend the dynamic range for emission measurements, or RF switching can be implemented to distribute the test signal to different test instruments.

## Exchangeable test antenna

The R&S®DST-B215 and R&S®DST-B220 broadband test antennas and the R&S®DST-B321 test antenna kit are designed as single modules that can be easily swapped as required for the specific application.



Bottom compartment containing RF and signal feedthrough connectors for conducted testing and path loss calibration.



Top compartment for installing RF circuits.

# High measurement accuracy and repeatability

## Outstanding RF characteristics

The R&S®DST200 is a compact, RF shielded anechoic chamber with an integrated broadband cross-polarized or circular-polarized test antenna for the frequency range from 400 MHz to 18 GHz.

Free-space conditions are achieved at the EUT test position through the optimized design and layout of the pyramidal RF absorbers. This minimizes parasitic loading of the EUT as well as antenna detuning caused by conductive parts of the chamber frame.

For example, testing the performance of GPS receivers down to very low levels of  $-160$  dBm requires perfect RF shielding of the test setup. The R&S®DST200 features outstanding shielding effectiveness of 110 dB and blocks all interferers present, whether they originate from adjacent test setups in the lab or from external sources such as base stations or TV transmitters.

## High field uniformity for variable EUT positions

The R&S®DST-B220 circular-polarized test antenna provides high uniformity of the electric field at the EUT location, allowing reproducible results to be obtained even when the position of the EUT is slightly changed.

RF chambers with near-field antenna couplers typically require a fixture for precise EUT positioning. With the R&S®DST200, the wireless device is simply placed on the table at the bottom of the chamber; no complicated positioning is required.

### Maximum variation of electric field

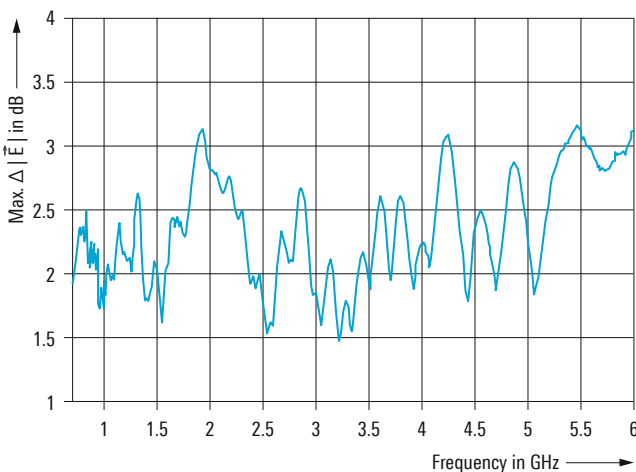

Maximum variation of electric field throughout cylindrical EUT volume above EUT table ( $\varnothing = 200$  mm,  $L = 30$  mm) when using the R&S®DST-B220 circular-polarized test antenna.

### Spatial distribution of electric field radiated by circular-polarized test antenna in two vertical planes

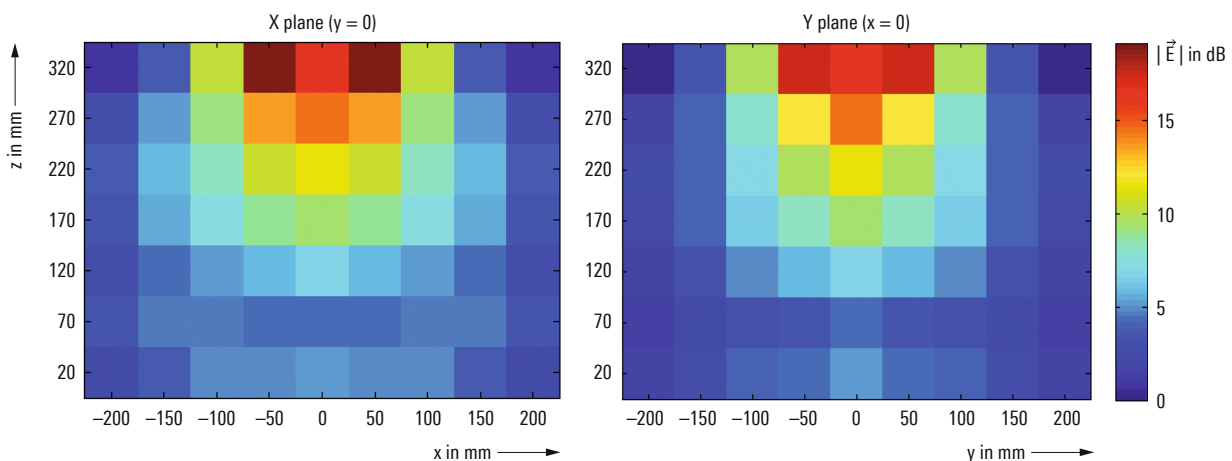

The origin of the coordinate system is at the center of the EUT table;  $f = 950$  MHz.

### Manual 3D positioner

The product design process often requires measurements with the EUT in a specific orientation to verify and optimize the antenna radiation pattern. An easy-to-operate manual 3D positioner (R&S®DST-B150) with two axes of rotation allows any orientation of the EUT in the polar coordinate system. The positioner has an open structure, offering easy access to the EUT buttons, switches or touchscreen for setting specific operating modes. Two angular scales for the two axes of rotation allow accurate EUT positioning and ensure reproducibility of the measurements. The positioner is designed for extremely low perturbation of the electric field at the EUT location.

The R&S®AMS32 measurement software supports interactive testing with manual EUT positioning and automated test data recording.

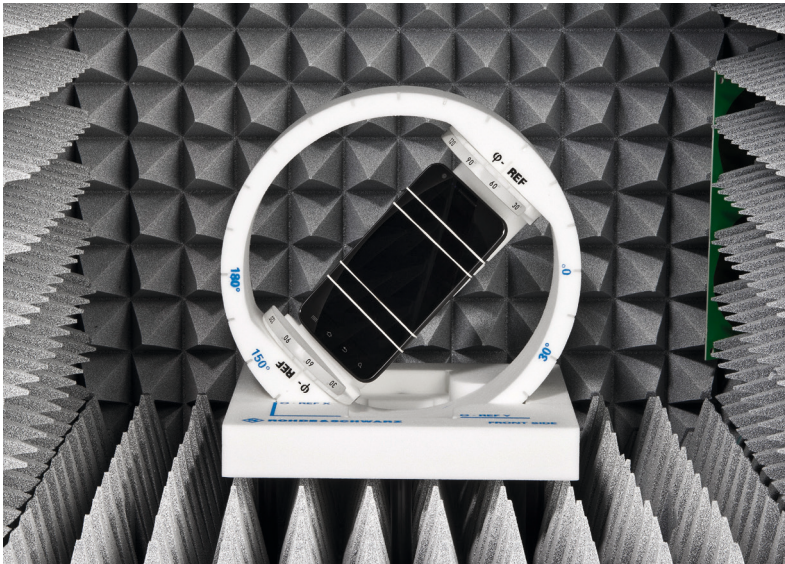

The R&S®DST-B150 manual 3D positioner with two axes of rotation sets the EUT to any desired polar position relative to the test antenna.

### Simple and effective front door locking mechanism

The unique front door locking mechanism significantly contributes toward the excellent RF shielding provided by the R&S®DST200. It is designed to support long-term operation without any pneumatic components.

The mechanically isolated door is locked into the groove of the chamber's main frame with a simple turn of the handle. Abrasion or bending of the RF gaskets is minimized, resulting in high availability and low service costs.

The symmetrical design of the front door allows the hinge to be mounted for left-hand or right-hand opening.



Front door locking mechanism.



# Broadband test and communications antennas

All test antennas for the R&S®DST200 are implemented as single modules and can be easily interchanged by the customer after opening the top cover.

## Cross-polarized Vivaldi test antenna

In OTA and RSE measurements, a series of 3D pattern tests are performed, taking both the  $\Theta$  and  $\Phi$  field components into account.

The R&S®DST-B215 cross-polarized Vivaldi test antenna has two sections arranged at right angles and connected to two RF ports. The antenna<sup>1)</sup> achieves broadband radiation characteristics in the frequency range from 400 MHz to 18 GHz and features a high cross-polarization ratio. The high gain of the R&S®DST-B215 results in increased signal-to-noise ratio for RSE measurements.

<sup>1)</sup> Patent pending.

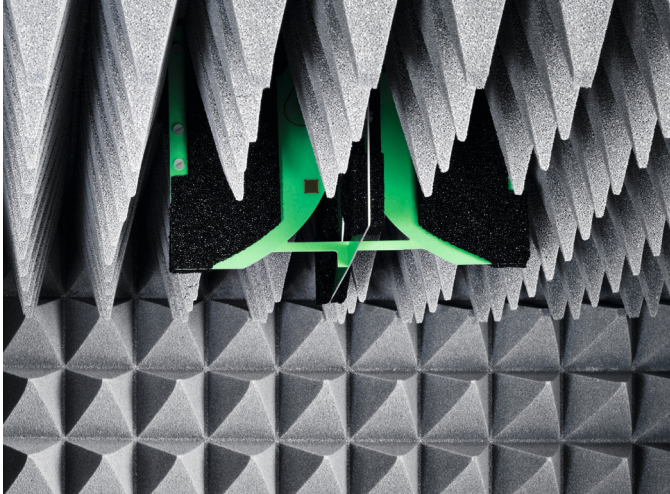

R&S®DST-B215 cross-polarized Vivaldi test antenna.

## Path loss between R&S®DST-B215 test antenna and R&S®DST-B160 3D positioner (typ.)

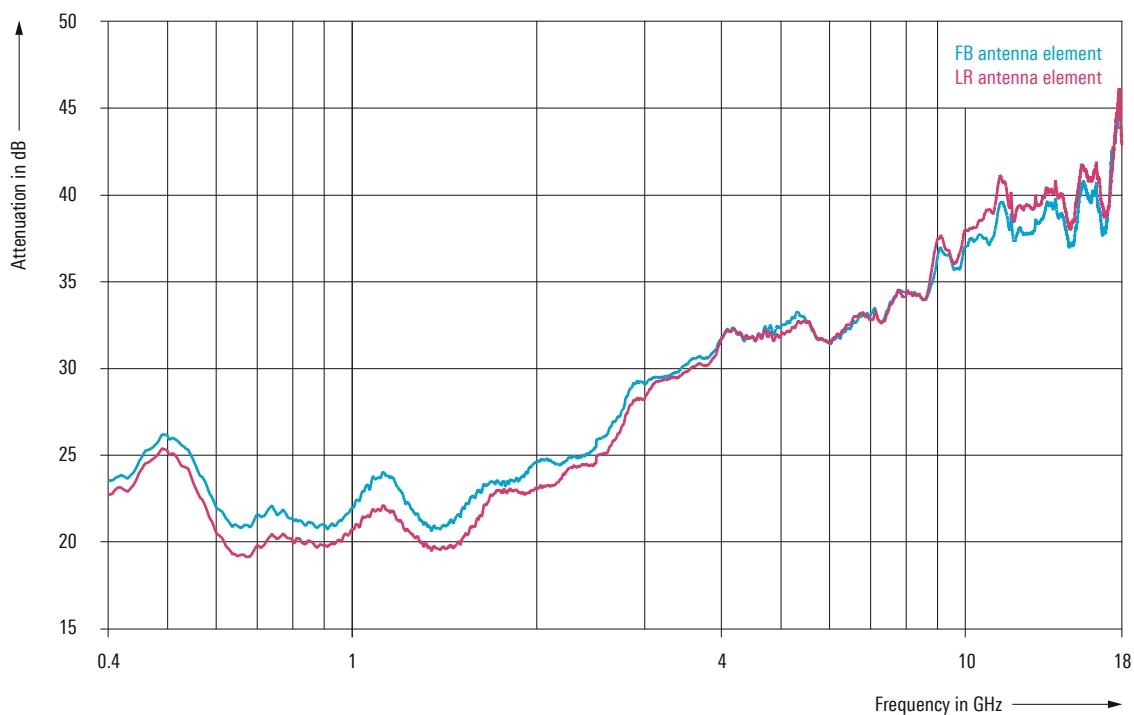



### Circular-polarized test antenna

The R&S®DST-B220 circular-polarized test antenna enables a direct connection to the test instrument input or output without the need of RF switching. The circular field polarization provides repeatable test results, even if the EUT is slightly shifted. Usual applications are desense testing and detection of EMI sources with a spectrum analyzer or test receiver.

### Test antenna kit – for tailored applications

The R&S®DST-B231 test antenna kit provides a basis for integrating a customized antenna for specific applications. It has an RF port outside of the R&S®DST200 and a soldering connector for printed-board antenna elements. RF absorbers – matching with the top absorber panel of the R&S®DST200 – retain the field uniformity. The rear metal plate of the R&S®DST-B231 closes the top compartment and thus maintains the excellent shielding effectiveness. In this case application specific test antennas can be placed at the lower part of the R&S®DST200 – closer to the EUT.

### Communications antennas

OTA measurements require a stable communications link while the EUT is being rotated by the 3D positioner for the pattern measurement. The R&S®DST-B270 option provides a linear-polarized radiation characteristic and is fixed at the bottom area inside the R&S®DST200 – close to the EUT. The R&S®DST-B272 option further improves the link stability with two linear-polarized antennas – combined by a power splitter. Mounting the antennas in horizontal and vertical orientation eliminates the effect of nulls in the 3D pattern to a large extent. Direct connections to the RF frontend of the R&S®CMW500 wideband radio communication tester of both test and communications antennas minimize the test setup. The uplink and downlink signal connections can be individually configured.

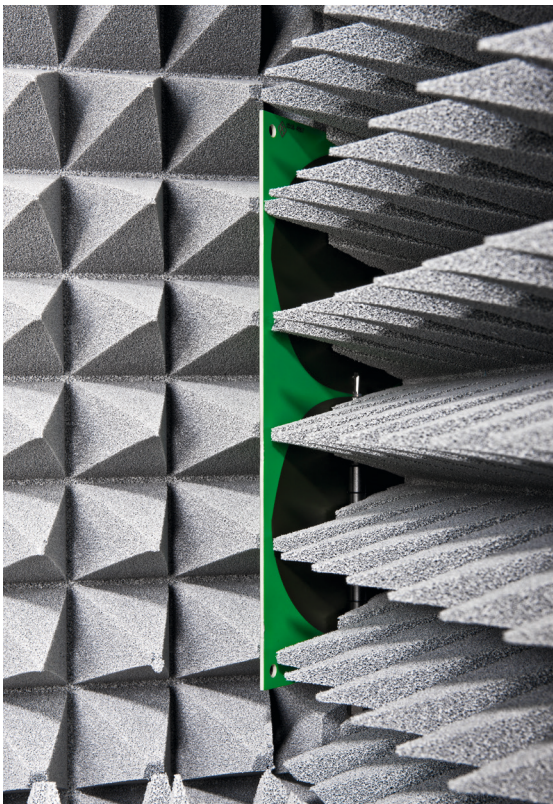

R&S®DST-B270 communications antenna in vertical arrangement – at the rear edge of the R&S®DST200.

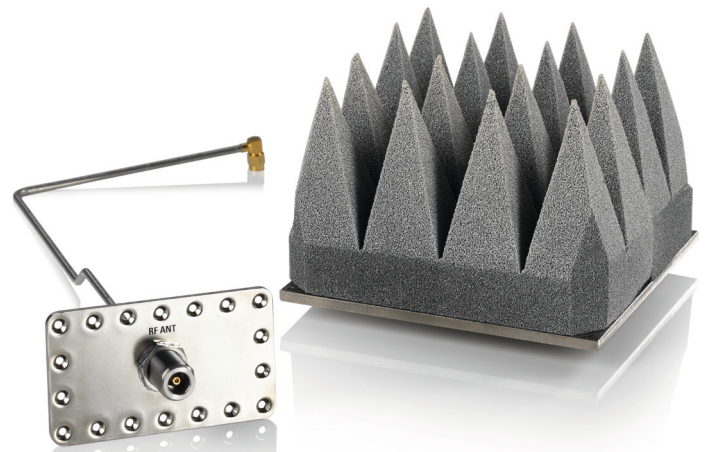

R&S®DST-B231 test antenna kit with single RF port.

# Automated 3D positioner for OTA and RSE measurements

## R&S®DST-B160 automated 3D positioner

The optional R&S®DST-B160 automated 3D positioner is the automated version of the R&S®DST-B150 manual 3D positioner. The EUT is attached to a removable holder at the center of the positioner and is rotated independently about the azimuth and elevation axes by two servomotors. An optical sensor ensures high positioning accuracy, allowing both axes of rotation to be automatically calibrated and reset to a defined start position.

The automated 3D positioner is remotely controlled via its RS-232 serial interface. The R&S®AMS32 OTA performance measurement software and the R&S®EMC32 EMC measurement software include drivers for this interface.

The servomotors and the motor control unit are accommodated in the RF shielded bottom compartment of the R&S®DST200, preventing EMI leakage to the outside, which could affect sensitive receiver measurements such as total isotropic sensitivity (TIS).

### The R&S®DST-B160 automated 3D positioner

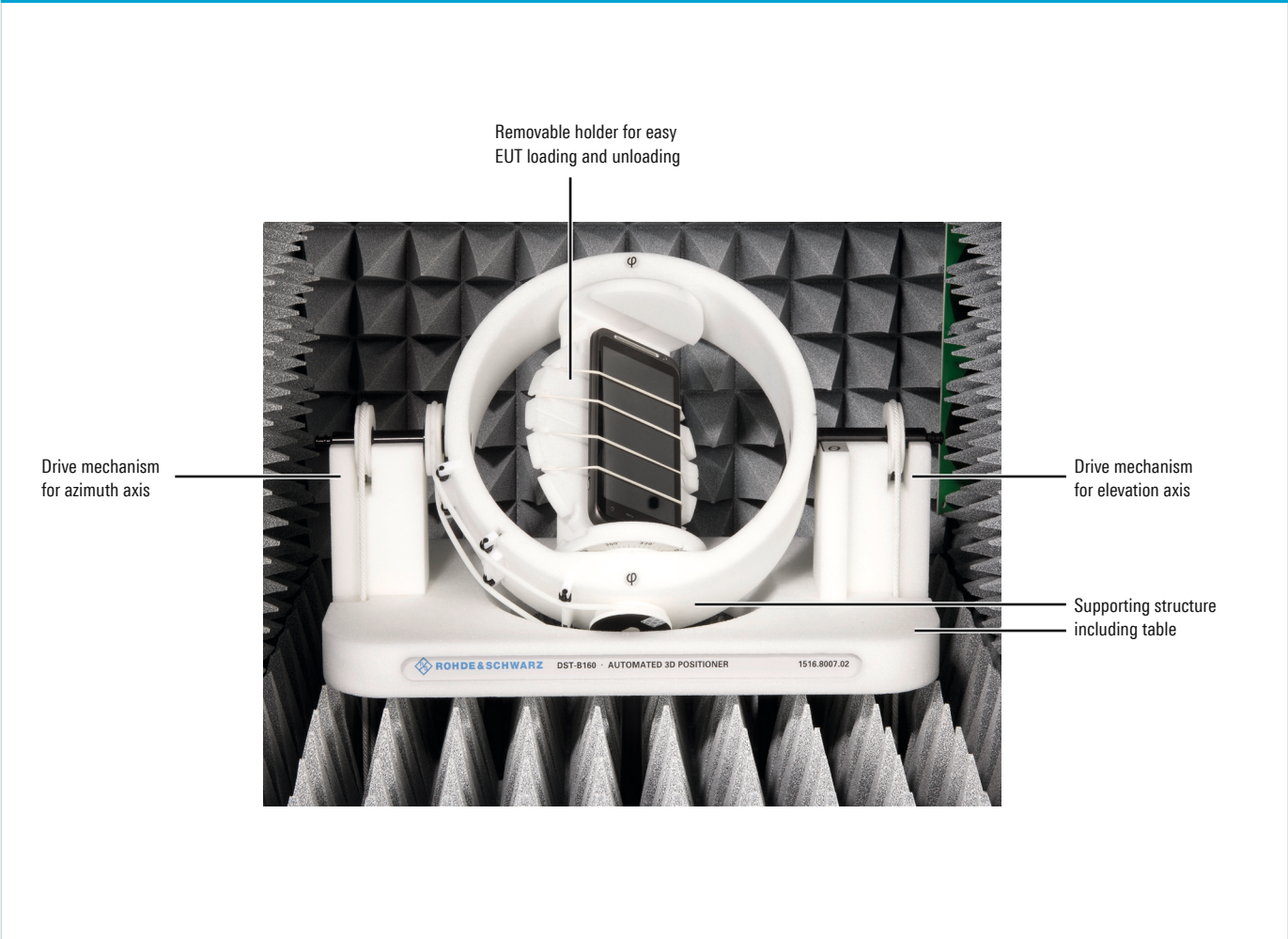



The supporting structure including the table is made of a very low relative permittivity ( $\epsilon_r$ ) material to minimize field perturbation in the EUT quiet zone. The supporting structure can be quickly and easily removed from the R&S®DST200 after releasing the two drive belts. It can be replaced with other EUT tables, for example to accommodate larger EUTs in a fixed test position.

### R&S®DST-B165 large automated 3D positioner

The R&S®DST-B165 large automated 3D positioner enables automated measurements of larger DUTs such as tablets or smartphones. The large positioner has the same mechanical characteristics as the R&S®DST-B160 and is able to perform measurements for heavier EUTs up to 800 grams.

The R&S®DST-U165 upgrade kit for the R&S®DST-B160 makes it possible to retrofit the R&S®DST200 with the larger 3D positioner while keeping the motor unit for both types.



# Excellent correlation with results of larger OTA and EMC test chambers

## Correlation of results obtained in different test chambers

The design of the R&S®DST-B160 automated 3D positioner – using very low relative permittivity ( $\epsilon_r$ ) material – and the radiation pattern of the R&S®DST-B215 cross-polarized test antenna are important factors that help to achieve high correlation of results between the R&S®DST200 and larger anechoic chambers.

This excellent result correlation is demonstrated by the following example: Multiple UEs were measured in a large wireless performance OTA chamber (5.0 m × 5.0 m × 5.0 m) and in the R&S®DST200 RF diagnostic chamber. The measurements made with the R&S®DST200 RF diagnostic chamber were repeated in order to verify reproducibility of results obtained with this chamber. These measurements show an excellent correlation of less than 1 dB.

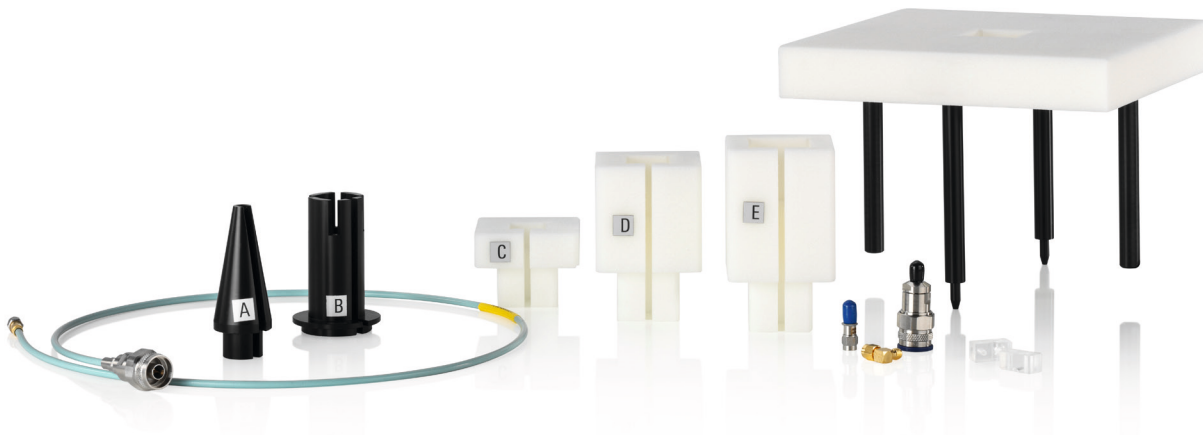

R&S®DST-B120 positioner kit for calibration antennas.

Correlation of OTA measurements between the R&S®DST200 and a 5 m OTA test chamber						
UE	Cellular standard	Test	Channel	Result of 5 m OTA chamber	Result of R&S®DST200	Delta R&S®DST200 vs. OTA chamber
UE1	GSM900	TRP	1	28.72 dBm	30.33 dBm	1.61 dB
	GSM1800	TRP	512	24.95 dBm	25.70 dBm	0.75 dB
	GSM900	TIS RSS	1	-106.7 dBm	-108.10 dBm	-1.40 dB
	GSM1800	TIS RSS	512	-104.81 dBm	-105.55 dBm	-0.74 dB
UE2	GSM900	TRP	1	28.53 dBm	29.59 dBm	1.06 dB
	GSM1800	TRP	512	28.96 dBm	29.16 dBm	0.20 dB



## Individual calibration of the R&S®DST200 RF diagnostic chamber

Every R&S®DST200 with installed R&S®DST-B215 Vivaldi test antenna provides the individual path calibration tables from the factory – ready to be imported to the R&S®AMS32 or R&S®EMC32 measurement software. In order to achieve a good correlation between measurements in an OTA chamber and the R&S®DST200, it is crucial to keep the R&S®DST200 calibration unchanged. Rohde&Schwarz recommends performing a new R&S®DST200 calibration whenever the measurement setup is modified, for example by adding different cables, antennas, etc.

The optional reference antennas for path loss calibration ensure an accurate measurement procedure that can also be performed on-site by the customer. There are two different biconical broadband antennas available depending on the required frequency range. The R&S®TS-RANT3 with a frequency range from 400 MHz to 3 GHz covers the cellular and WLAN low frequency bands. The R&S®TS-RANT18 with a frequency range from 3 GHz to 18 GHz assures precise calibration for higher frequencies.

The R&S®TS-RANT antennas are optionally provided with individual calibration data as gain, antenna factor tables and VSWR table (R&S®TS-RANT3C and R&S®TS-RANT18C options).

It is essential to perform the path loss calibration at the height where the DUT will be placed. The option R&S®DST-B120 is a positioner for calibration antennas as a ready-to-use kit.

The calibration table material used for the 3D positioners has a very low relative permittivity ( $\epsilon_r$ ) value.

It includes a base table and a set of adapters to place the reference antennas at multiple heights representing the center of rotation of the 3D positioners:

- 190 mm for the R&S®DST-B165
- 270 mm for the R&S®DST-B160
- 350 mm for the flat EUT table

An RF cable and RF adapters complete the kit, making it ready to run together with a network analyzer without the need of further components inside the R&S®DST200.

This assures a maximum flexibility when performing a calibration with the R&S®TS-RANT antennas.

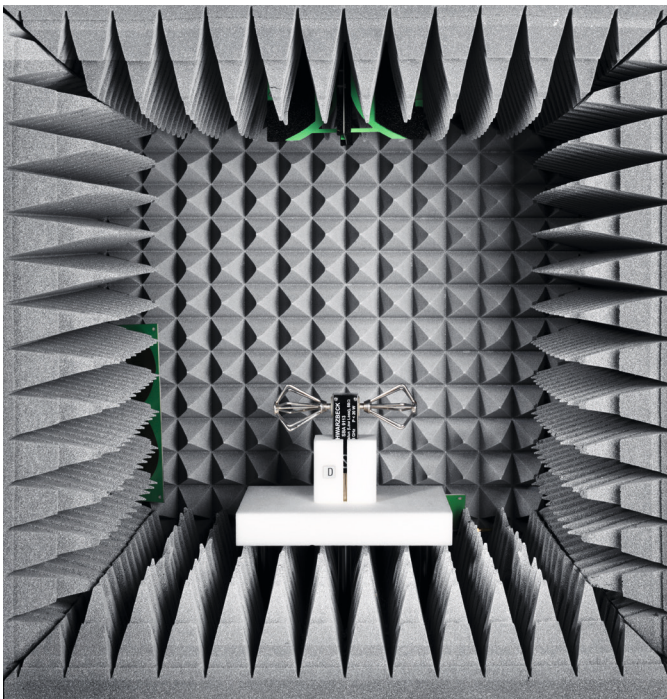

R&S®TS-RANT3 calibration antenna (500 MHz to 3 GHz).

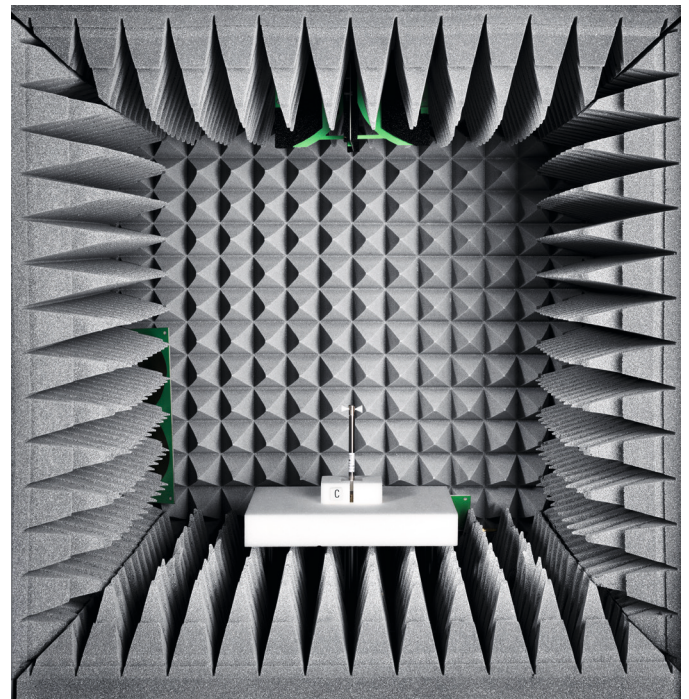

R&S®TS-RANT18 calibration antenna (3 GHz to 18 GHz).

# Automated measurements with ready-to-use test templates

## Radiated measurements at a mouse click

The comprehensive R&S®AMS32 OTA performance measurement software supports various test applications with the R&S®DST200 RF diagnostic chamber:

- Intermediate receiver sensitivity test for determining desense effects across the operating band
- Coexistence test to verify receiver performance with multiple radio services active simultaneously in a wireless device (e.g. LTE or GSM in the presence of Bluetooth®)
- Verification of over-the-air (OTA) performance for SISO and MIMO mode
- Envelope correlation coefficient (ECC) measurement between two receiving antennas

Radiated spurious emissions (RSE) can be measured with the R&S®EMC32 EMC measurement software.

Test templates for all common wireless standards are available for both R&S®AMS32 and R&S®EMC32. The templates require no programming and are ready to use. Tests can be easily configured using a menu-driven setup for parameters such as cellular band, channel list and power level.

## Documenting results made easy

The integrated report function of the R&S®AMS32 and R&S®EMC32 software compiles all measured data such as graphical and numerical results, test environments, EUT data and hardware setup in a single document. The report layout can be customized, and the result file saved in several different standard formats.

During the design optimization process for a wireless device, several cycles with repeated measurements under the same test conditions need to be performed. By importing and displaying previous result graphs, the effects of design changes and improvements can be made visible immediately.

The R&S®AMS32 and R&S®EMC32 software can be used for measurements both with the R&S®DST200 and larger RF test chambers. This reduces operational costs and simplifies the comparison of results.

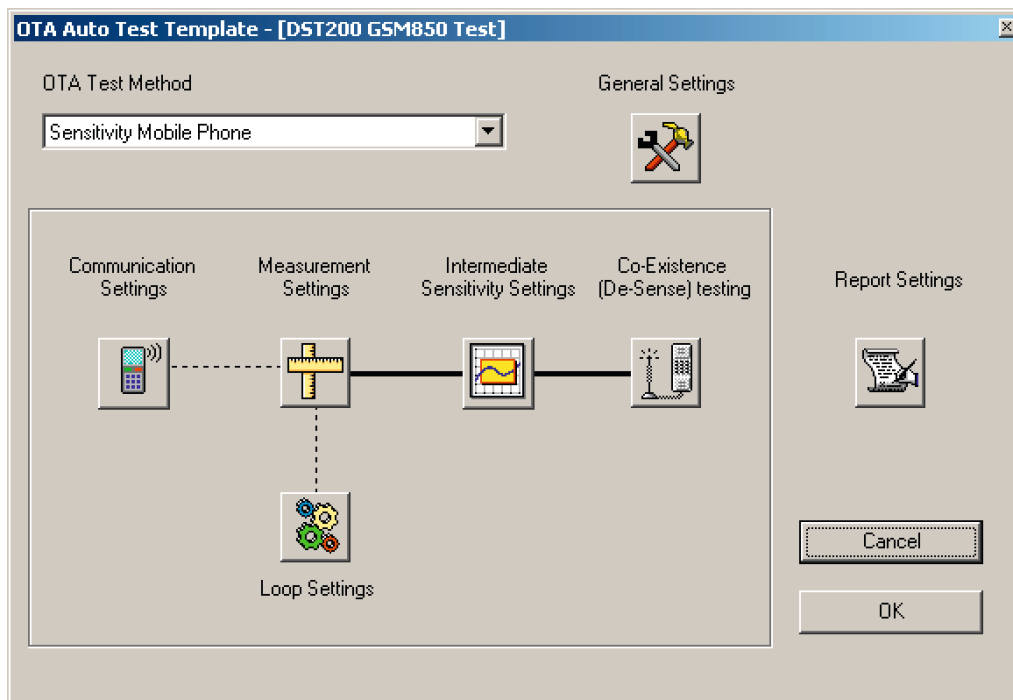

R&S®AMS32 configuration menu for desense and coexistence testing.

# Application

## Radiated performance testing to verify product quality

### Verification of over-the-air (OTA) performance

To measure total radiated power (TRP) and total isotropic sensitivity (TIS) as specified by CTIA and, similarly, 3GPP, the R&S®DST200 supports measurement of both the radiated antenna pattern and the receiving characteristics. The results correlate with those of larger over-the-air (OTA) test chambers. The antenna design of a wireless device can be optimized in the R&D lab, without requiring constant access to large, external test chambers.

### A-GPS testing with the R&S®DST200

Compared with standalone GPS, assisted GPS (A-GPS) reduces the time needed to calculate the position of a wireless device. In addition to satellite information, A-GPS uses information from the base station, such as accurate coordinates of the cell base stations and almanac data. A-GPS capability is a key requirement in order to meet the US Federal Communications Commission (FCC) wireless 911 rules requiring service providers to deliver fast and reliable location information even under poor signal conditions.

The R&S®DST-B160 automated 3D positioner and R&S®DST-B215 cross-polarized test antenna are mandatory options for performing A-GPS measurements with the R&S®DST200. The R&S®SMBV100A vector signal generator simulates eight satellites, whose downlink signals are applied to the test antenna in the R&S®DST200 in the  $\Theta$  and  $\Phi$  orthogonal polarization planes. The EUT extracts information such as position data and received signal level from the satellite data and sends it to the R&S®CMW500 wideband radio communication tester via a cellular link.

A-GPS measurements in conformance with the CTIA OTA test plan can be very time consuming. Testing multistandard smartphones can take several hours, for example. The compact R&S®DST200 makes it possible to perform such measurements right on the lab bench. Product optimization takes place in the lab, and developers no longer require constant access to large OTA test chambers, which are often unavailable at short notice.

Example of antenna pattern showing TRP for LTE band 13 (782 MHz)

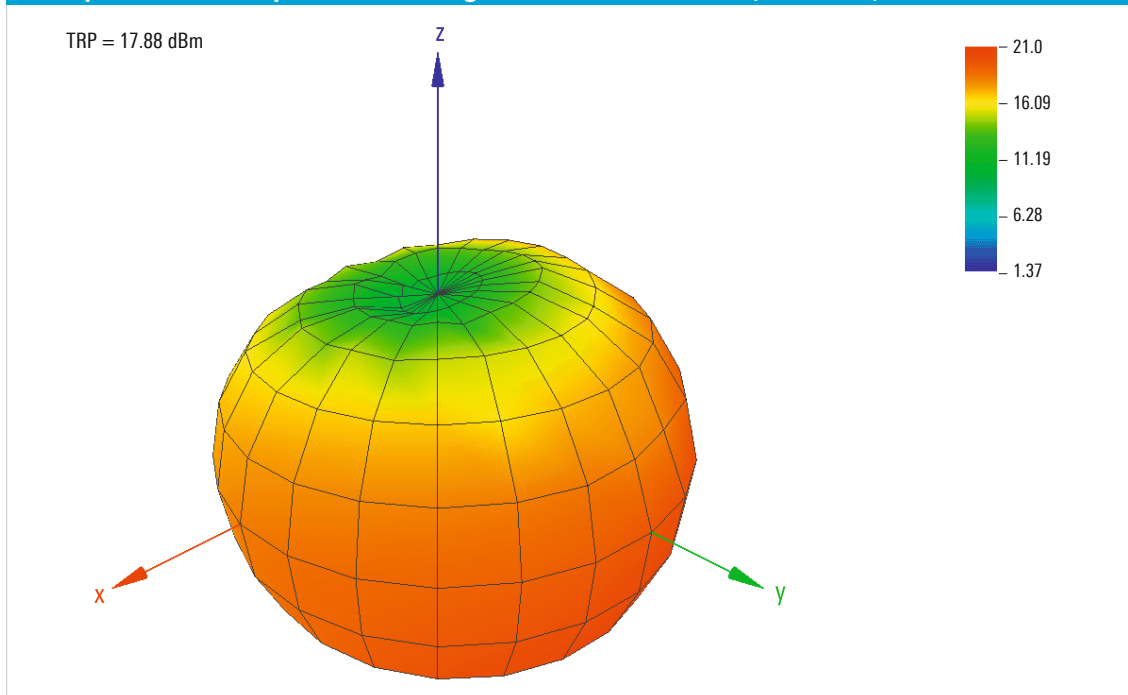

## Easy-to-use test setup for MIMO performance testing

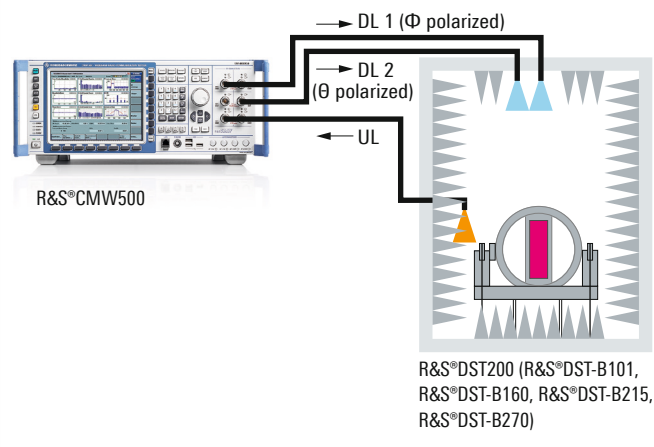

## Result of desense test showing self-interference on two channels of a GSM 900 band

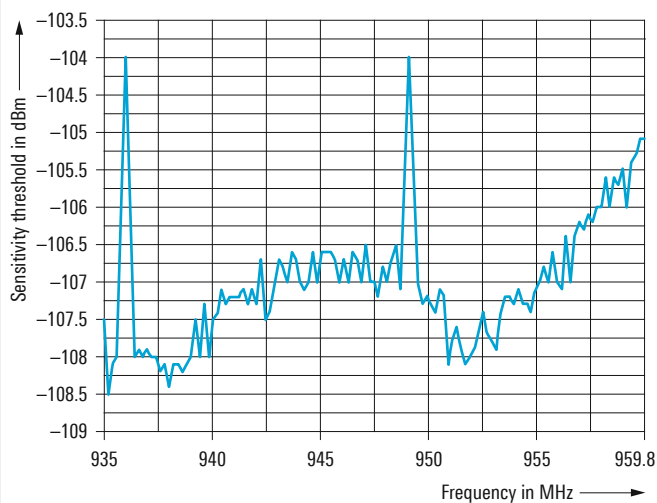

## Result of a GSM 850 RSE test with a third harmonic on the uplink carrier

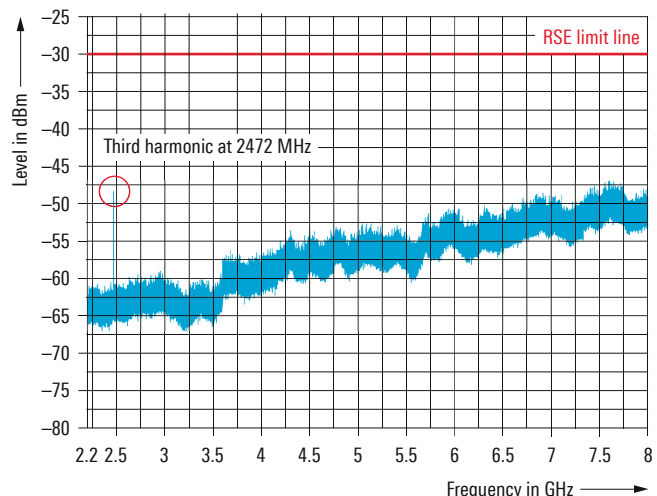

## MIMO performance testing made easy

The performance gain achieved with 2x2 MIMO in the downlink – data throughput twice as high as with SISO – has to be verified at various stages in a product’s lifecycle:

- In R&D, e.g. during antenna design
- In production, for quality assurance
- In servicing, for quality assurance
- In qualification measurements

Pass/fail measurements and qualification measurements on MIMO-enabled wireless devices can be performed with the R&S<sup>®</sup>DST200 using a compact and simple test setup. The two downlink streams from the R&S<sup>®</sup>CMW500, which simulates the base station, are connected to the two ports of the R&S<sup>®</sup>DST-B215 cross-polarized test antenna. The automated 3D positioner aligns the EUT in any desired orientation in the polar coordinate system to provide a complete picture of the spatial MIMO characteristics. Receiver sensitivity is plotted in a 3D diagram that reveals any sensitivity degradation in partial areas. Statistical results are plotted versus the receiver input power level.

## Desense testing (self-interference)

Multistandard smartphones integrate multiple functional blocks in the smallest possible space in order to meet market requirements. The different components can interfere with each other, degrading performance especially in the receiver component. This effect is called desense and is caused by oscillator harmonics, internal noise on the printed board and antenna crosstalk. Emissions from the display, camera or other functional blocks can also cause interference.

Desense measurements require a link with a radio communication tester (such as the R&S<sup>®</sup>CMU200, R&S<sup>®</sup>CMW500 or R&S<sup>®</sup>CBT) to provide the required cellular or wireless service. After the link is established, the bit error rate (BER) or packet error rate (PER) is measured while a potential interference source is active (for example the display).

## Coexistence testing

Another important design test involves verifying the correct, simultaneous operation of multiple cellular or wireless services (such as GSM, LTE, WLAN, GPS, Bluetooth<sup>®</sup> or Wi-Fi) in a wireless device. This is usually done by first setting up a communications link with a potential interference source. Next, the potentially affected service is tested by measuring receiver degradation using the same method as for desense testing.

Test cases for coexistence testing are specified by the CTIA wireless association in the “Test Plan for RF Performance Evaluation of Wi-Fi Mobile Converged Devices”.



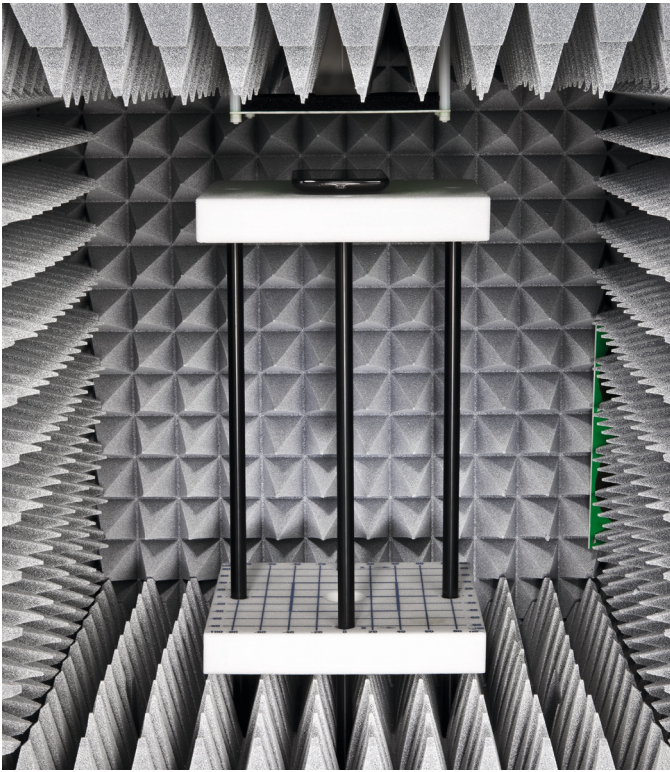

R&S®DST-B130 elevated EUT table.

## Measurement of radiated spurious emissions (RSE)

The frequency spectrum is a valuable resource for service providers. It is therefore crucial that network capacity should not be reduced by spurious emissions from wireless devices. Radiated harmonics and other spurious emissions need to be measured in line with 3GPP and ETSI test specifications for cellular and other wireless standards. Other mandatory tests have been defined by the US Federal Communications Commission (FCC) and also specified in the European R&TTE.

Spurious emissions in the operating band as well as out-of-band emissions that may affect other services have to be below a specified limit. In-band tests require suppression of the carrier frequency to prevent overloading of the test receiver input. The R&S®OSP-F7B modular filter unit includes switchable notch filters that can be configured for specific operating bands. The R&S®OSP-F7B is inserted between the test antenna of the R&S®DST200 and the input of the test receiver. The R&S®OSP-B155 compact filter module enables RSE measurements in all LTE operating bands without the use of notch filters.

## Detection of EMI sources

Oscillator harmonics in the operating band can cause desense effects. To carry out an overview measurement, all that is needed is a test receiver to perform a frequency sweep. The RF transceiver of the EUT remains switched off. For increased sensitivity, the EUT can be moved closer to the test antenna using the R&S®DST-B130 elevated EUT table.



Test setup for desense measurements with the R&S®CMW500 wideband radio communication tester.

# Specifications in brief

Specifications in brief		
<b>RF specifications</b>		
Frequency range		400 MHz to 18 GHz
Antenna polarization	R&S°DST-B215 option	cross-polarized
	R&S°DST-B220 option	right-hand circular-polarized
	R&S°DST-B270 and R&S°DST-B270 options	linear-polarized
Shielding effectiveness	base unit with R&S°DST-B102 option	
	400 MHz to 700 MHz	> 95 dB (meas.)
	700 MHz to 3 GHz	> 110 dB
	3 GHz to 6 GHz	> 100 dB
	6 GHz to 18 GHz	> 75 dB (meas.)
Quiet zone	above EUT table, Ø × L (cylindrical)	200 mm × 30 mm (7.9 in × 1.2 in)
Field uniformity	max. field variation in quiet zone with R&S°DST-B220 option	< 3.2 dB (meas.)
Field perturbation	with R&S°DST-B150 option	
	300 MHz to 2.7 GHz	−0.6 dB to +0.6 dB (meas.)
	2.7 GHz to 6 GHz	−1.5 dB to 1.5 dB (meas.)
	with R&S°DST-B160 option	
	700 MHz to 2.7 GHz	−1 dB to +1 dB (meas.)
	2.7 GHz to 6 GHz	−2.3 dB to +2.3 dB (meas.)
<b>RF connectors</b>		
RF feedthrough connectors	R&S°DST-B102 option	2 × N, female
Test antenna	R&S°DST-B215 option	2 × N, female
	R&S°DST-B220 option	1 × N, female
	R&S°DST-B231 option	1 × N, female
<b>Feedthrough filters</b>		
Lowpass filter panel and fiber-optic interface	R&S°DST-B101 option	1 × 9-pin D-Sub socket adapter, 2 × FSMA
USB lowpass filter panel	R&S°DST-B103 option	1 × USB 2.0 type A connector, female
AC lowpass filter	R&S°DST-B104 option	1 × 100 V to 240 V
<b>General data</b>		
Dimensions	W × H × D, with locking handle	770 mm × 760 mm × 695 mm (30.3 in × 29.9 in × 27.4 in)
Weight		approx. 55 kg (121 lb)
Max. EUT dimensions	W × H × D	400 mm × 330 mm × 400 mm (15.7 in × 13.0 in × 15.7 in)
	R&S°DST-B150 option	150 mm × 100 mm × 20 mm (5.9 in × 3.9 in × 0.8 in)
	R&S°DST-B160 option	149 mm × 100 mm × 20 mm (5.9 in × 3.9 in × 0.8 in)
	R&S°DST-B165 option	257 mm × 190 mm × 20 mm (10.1 in × 7.5 in × 0.8 in)
	Max. EUT weight	allowed on EUT table supplied with R&S°DST200 base unit
	R&S°DST-B150 option	0.2 kg (0.44 lb)
	R&S°DST-B160 option	0.2 kg (0.44 lb)
	R&S°DST-B165 option	0.8 kg (1.6 lb)
Operating cycles	front door locking mechanism	min. 66 000 cycles

For data sheet, see 5214.3600.22 and [www.rohde-schwarz.com](http://www.rohde-schwarz.com).

# Ordering information

Designation	Type	Order No.
<b>Base unit</b>		
RF Diagnostic Chamber	R&S®DST200	1510.9047.02
<b>Base unit configuration, mandatory</b>		
R&S®DST200 Selection: Left-Hand Door Mounting	R&S®DST-S100A	1515.1396.02
R&S®DST200 Selection: Right-Hand Door Mounting	R&S®DST-S100B	1515.1396.03
Cross-Polarized Vivaldi Test Antenna for R&S®DST200 <sup>1)</sup>	R&S®DST-B215	1527.3576.02
Circular-Polarized Test Antenna for R&S®DST200 <sup>1)</sup>	R&S®DST-B220	1518.4509.02
Test Antenna Kit for R&S®DST200 <sup>1)</sup>	R&S®DST-B231	1518.5328.02
<b>Hardware options</b>		
Filter Panel for R&S®DST200, 9-pin D-Sub, fiber-optic	R&S®DST-B101	1514.7778.02
Interface Panel for R&S®DST200, 2 x N, 2 x RF cable	R&S®DST-B102	1514.7784.02
Filter Panel for R&S®DST200, USB 2.0	R&S®DST-B103	1514.7790.02
Filter Panel for R&S®DST200, 100 V to 240 V AC	R&S®DST-B104	1516.8407.02
Positioner for Calibration Antennas	R&S®DST-B120	1516.8659.02
Elevated EUT Table for R&S®DST200	R&S®DST-B130	1515.1467.02
Manual 3D Positioner for R&S®DST200	R&S®DST-B150	1515.1480.02
Automated 3D Positioner for R&S®DST200	R&S®DST-B160	1516.8007.02
Large Automated 3D Positioner for R&S®DST200	R&S®DST-B165	1519.3506.02
Upgrade Kit for the R&S®DST-B160	R&S®DST-U165	1519.3935.02
Cross-Polarized Vivaldi Test Antenna for R&S®DST200 <sup>1)</sup>	R&S®DST-B215	1527.3576.02
Circular-Polarized Test Antenna for R&S®DST200	R&S®DST-B220	1518.4509.02
Test Antenna Kit for R&S®DST200 <sup>1)</sup>	R&S®DST-B231	1518.5328.02
Linear-Polarized Communications Antenna for R&S®DST200	R&S®DST-B270	1518.4515.02
Linear-Polarized Communications Antenna, 2 pcs., power splitter	R&S®DST-B272	1518.4609.02
<b>Software options</b>		
Over-the-Air (OTA) Performance Measurement Software <sup>2)</sup>	R&S®AMS32	1508.6650.02
OTA Measurement Software Basic Package for R&S®DST200 <sup>2)</sup>	R&S®AMS32-DST	1518.5270.02
Software License Package for R&S®AMS32-DST, basic license, includes GSM, CDMA, WCDMA and LTE <sup>3)</sup>	R&S®AMS32-PK20	1518.5286.02
Software License Package for R&S®AMS32-DST, basic license, includes GSM, CDMA, TD-SCDMA, WCDMA, LTE, WLAN and Bluetooth <sup>3)</sup>	R&S®AMS32-PK25	1518.5286.25
EMC Measurement Software <sup>2)</sup>	R&S®EMC32-EB	1300.7010.02
<b>Recommended extras</b>		
Shipping Container for R&S®DST200	R&S®DST-Z5	1518.9530.02
RF Cable, 18 GHz, 1.5 m, 2 x N connector, high shielding effectiveness	R&S®DST-Z18	1515.1473.02
EUT Holder for R&S®DST-B160	R&S®DST-Z160	1518.5205.02
EUT Holder for R&S®DST-B165	R&S®DST-Z165	1519.3941.02
Linear-Polarized Calibration Antenna, 400 MHz to 3 GHz	R&S®TS-RANT3	1516.4224.02
Antenna Calibration Data for R&S®TS-RANT3C: gain, AF, VSWR	R&S®TS-RANT3C	1516.4224.05
Linear-Polarized Calibration Antenna, 3 GHz to 18 GHz	R&S®TS-RANT18	1516.4218.02
Antenna Calibration Data for R&S®TS-RANT18C: gain, AF, VSWR	R&S®TS-RANT18C	1516.4218.05

<sup>1)</sup> Selection of R&S®DST-B215, R&S®DST-B220 or R&S®DST-B231 is mandatory (factory-installed).

<sup>2)</sup> Selection of option as required for your application. Please contact your local Rohde&Schwarz expert.

<sup>3)</sup> Requires R&S®AMS32-DST.

Your local Rohde&Schwarz expert will help you determine the optimum solution for your requirements.

To find your nearest Rohde&Schwarz representative, visit

[www.sales.rohde-schwarz.com](http://www.sales.rohde-schwarz.com)

## Service that adds value

- | Worldwide
- | Local and personalized
- | Customized and flexible
- | Uncompromising quality
- | Long-term dependability

## About Rohde & Schwarz

The Rohde & Schwarz electronics group offers innovative solutions in the following business fields: test and measurement, broadcast and media, secure communications, cybersecurity, radiomonitoring and radiolocation. Founded more than 80 years ago, this independent company has an extensive sales and service network and is present in more than 70 countries. The electronics group is among the world market leaders in its established business fields. The company is headquartered in Munich, Germany. It also has regional headquarters in Singapore and Columbia, Maryland, USA, to manage its operations in these regions.

## Sustainable product design

- | Environmental compatibility and eco-footprint
- | Energy efficiency and low emissions
- | Longevity and optimized total cost of ownership

Certified Quality Management

**ISO 9001**

Certified Environmental Management

**ISO 14001**

## Rohde & Schwarz GmbH & Co. KG

[www.rohde-schwarz.com](http://www.rohde-schwarz.com)

## Rohde & Schwarz training

[www.training.rohde-schwarz.com](http://www.training.rohde-schwarz.com)

## Regional contact

- | Europe, Africa, Middle East | +49 89 4129 12345  
[customersupport@rohde-schwarz.com](mailto:customersupport@rohde-schwarz.com)
- | North America | 1 888 TEST RSA (1 888 837 87 72)  
[customer.support@rsa.rohde-schwarz.com](mailto:customer.support@rsa.rohde-schwarz.com)
- | Latin America | +1 410 910 79 88  
[customersupport.la@rohde-schwarz.com](mailto:customersupport.la@rohde-schwarz.com)
- | Asia Pacific | +65 65 13 04 88  
[customersupport.asia@rohde-schwarz.com](mailto:customersupport.asia@rohde-schwarz.com)
- | China | +86 800 810 82 28 | +86 400 650 58 96  
[customersupport.china@rohde-schwarz.com](mailto:customersupport.china@rohde-schwarz.com)

R&S® is a registered trademark of Rohde & Schwarz GmbH & Co. KG

Trade names are trademarks of the owners

PD 5214.3600.12 | Version 03.00 | April 2016 (ch)

R&S®DST200 RF Diagnostic Chamber

Data without tolerance limits is not binding | Subject to change

© 2010 - 2016 Rohde & Schwarz GmbH & Co. KG | 81671 Munich, Germany



5214360012