

# ShockLine™

## MS46522B, MS46524B Series

### Vector Network Analyzers

MS46522B-010 VNA, 50 kHz to 8.5 GHz, 2-Port

MS46522B-020 VNA, 50 kHz to 20 GHz, 2-port

MS46522B-040 VNA, 50 kHz to 43.5 GHz, 2-port

MS46522B-082 VNA, 55 GHz to 92 GHz, 2-port

MS46524B-010 VNA, 50 kHz to 8.5 GHz, 4-port

MS46524B-020 VNA, 50 kHz to 20 GHz, 4-port

MS46524B-040 VNA, 50 kHz to 43.5 GHz, 4-port



Anritsu



# Table of Contents

---

## Chapter 1—Calibration Overview

1-1	Manual Scope . . . . .	1-1
1-2	Chapter Summary . . . . .	1-1
1-3	Related Documentation . . . . .	1-1
	Product Information, Compliance, and Safety . . . . .	1-1
	ShockLine™ MS46522B/MS46524B . . . . .	1-1
	Calibration, Verification, and System Performance Verification . . . . .	1-1
1-4	Calibration Kits, Verification Kits, and Components . . . . .	1-2
	Calibration/Verification Equipment Part Numbers and General Specifications . . . . .	1-2
1-5	AutoCal™ Automatic Calibration Modules . . . . .	1-4
	Calibrations Available . . . . .	1-4
1-6	SOLT Kits (365xx) . . . . .	1-4
1-7	Offset Short Waveguide Kits (3655X) . . . . .	1-6
1-8	Microstrip/Coplanar Waveguide Kits for the UTF (36804-XXX) . . . . .	1-6
1-9	On-Wafer Calibration Kits . . . . .	1-6
1-10	Calibration Algorithms . . . . .	1-6
1-11	About Calibration . . . . .	1-6
	Match . . . . .	1-6
	Directivity . . . . .	1-7
	Frequency Response . . . . .	1-7
	Calibration Types . . . . .	1-7
	Calibration Algorithms . . . . .	1-8
1-12	Calibration Setup . . . . .	1-9
	Frequency Start, Stop, and Number of Points . . . . .	1-9
	IF Bandwidth, Averaging and Power . . . . .	1-9
1-13	Types of Calibrations . . . . .	1-10
	Full 4 Port . . . . .	1-10
	Full 2 Port . . . . .	1-10
	Full 1 Port . . . . .	1-10
	1 Path 2 Port (Forward or Reverse) . . . . .	1-10
	Reflection and Transmission Frequency Response . . . . .	1-10
1-14	Line Types (Transmission Media) . . . . .	1-12
1-15	Preparing a Sliding Load (Termination) Calibration Kit . . . . .	1-14
	Procedure . . . . .	1-14
1-16	Connector Precautions . . . . .	1-24
	Pin Depth . . . . .	1-24
	Pin Depth Tolerance . . . . .	1-24
	Over-Torquing Connectors . . . . .	1-25
	Teflon Tuning Washers . . . . .	1-25
	Mechanical Shock . . . . .	1-25

## Table of Contents (Continued)

---

1-17	Connector Cleaning . . . . .	1-26
	Required Cleaning Items . . . . .	1-26
	Cleaning Procedure . . . . .	1-26

### Chapter 2—Automatic Calibration

2-1	Chapter Overview . . . . .	2-1
2-2	Automatic Calibration Introduction . . . . .	2-1
	Transfer Calibration . . . . .	2-1
	Calibration Accuracy . . . . .	2-1
2-3	Automatic Calibration Terms . . . . .	2-2
	Insertable and Non-Insertable Devices . . . . .	2-2
	Auto-Sense . . . . .	2-2
	Characterization File . . . . .	2-2
2-4	Calibrator Modules, Adapters and Features . . . . .	2-3
	AutoCal Description, Modules and Adapters . . . . .	2-4
	SmartCal Description, Modules and Adapters . . . . .	2-4
	Connector Care . . . . .	2-4
	Calibration Parameters and Types . . . . .	2-5
	Adapter Removal . . . . .	2-6
	Through Options . . . . .	2-6
	SmartCal Test Port 1 / Port 2 Naming Assignments . . . . .	2-6
	AutoCal Test Port Left/Right Naming Assignments . . . . .	2-6
	Typical Calibrator Connections . . . . .	2-7
2-5	Using the Calibration Module . . . . .	2-9
2-6	Copying the Calibrator Characterization File to the MS4652xB (AutoCal Only) . . . . .	2-10
2-7	Loading a Previously Stored AutoCal Characterization File . . . . .	2-11
	Procedure . . . . .	2-11
2-8	Pre-Calibration Instrument Setup . . . . .	2-12
	Segmented Sweep . . . . .	2-12
	IF Bandwidth (IFBW) and Averaging . . . . .	2-12
	Port Power . . . . .	2-12
	Example Procedure . . . . .	2-12
2-9	Calibration – Full Two Port - Internal Through . . . . .	2-15
	Required Equipment . . . . .	2-15
	Procedure . . . . .	2-15
2-10	Calibration – Two Port Cal - True Through . . . . .	2-20
	Required Equipment . . . . .	2-20
	Procedure . . . . .	2-20
2-11	Calibration – Full Four Port - Internal Through . . . . .	2-25
	Required Equipment . . . . .	2-26
	Procedure . . . . .	2-26
2-12	Calibration – Four Port Cal - True Through . . . . .	2-31
	Required Equipment . . . . .	2-31
	Procedure . . . . .	2-31



## Table of Contents (Continued)

---

2-13	Calibration Module Characterization . . . . .	2-35
	Characterization . . . . .	2-35
2-14	Adapter Removal – M-M or F-F Reference Plane . . . . .	2-36
	Adapter Removal Overview . . . . .	2-36
	Required Equipment . . . . .	2-36
	Prerequisites . . . . .	2-36
	Procedure . . . . .	2-36

### Chapter 3—SOLT/SOLR Calibration

3-1	SOLT/SOLR Introduction . . . . .	3-1
3-2	Definitions . . . . .	3-1
	Shorts . . . . .	3-1
	Opens . . . . .	3-1
	Loads . . . . .	3-1
	Thru . . . . .	3-1
	Reciprocal . . . . .	3-1
3-3	2-Port Cal Setup . . . . .	3-2
	MS46524B Two 2-Port . . . . .	3-3
3-4	SOLT/SOLR Calibration . . . . .	3-8

### Chapter 4—Offset Short (SSLT) Calibration

4-1	SSLT Introduction . . . . .	4-1
4-2	SSLT Calibration Example . . . . .	4-2

### Chapter 5—Triple Offset Short (SSST) Calibration

5-1	SSST Introduction . . . . .	5-1
5-2	SSST and Reflectivity Error Terms . . . . .	5-1
5-3	SSST Waveguide Calibration Example . . . . .	5-4

### Chapter 6—LRL/LRM Calibration

6-1	LRL/LRM Introduction . . . . .	6-1
6-2	LRL/LRM Comparison . . . . .	6-1
	LRL - Line-Reflect-Line . . . . .	6-1
	LRM - Line-Reflect-Match . . . . .	6-1
	Reflection Offset Length and Reflection Type . . . . .	6-4
	Load Model/Characterization for LRM . . . . .	6-4
6-3	LRL/LRM Calibration Step-by-Step Example . . . . .	6-5
	Procedure . . . . .	6-6
6-4	Hints and Suggestions . . . . .	6-9

### Chapter 7—Receiver Calibrations

7-1	Receiver Calibration Overview . . . . .	7-1
7-2	Receiver Calibration Concepts . . . . .	7-1
7-3	Setting Up Receiver Calibrations . . . . .	7-4
7-4	Receiver Calibration Utilities . . . . .	7-9

## Table of Contents (Continued)

---

7-5	Receiver Calibration Uncertainties . . . . .	7-11
	Source Side . . . . .	7-11
	Receiver Side . . . . .	7-11

### Chapter 8—Adapter Removal Calibration and Network Extraction

8-1	Introduction . . . . .	8-1
8-2	Two Related Sets of Reference Planes . . . . .	8-1
	Caveats and Limitations . . . . .	8-2
8-3	Performing an Adapter Removal . . . . .	8-6
	Example Adapter Removal . . . . .	8-7
8-4	Network Extraction . . . . .	8-8
	Type A - Two Full 2-Port Cals . . . . .	8-8
	Type B - Two Tier Two 1-Port Cals . . . . .	8-8
	Type C - Inner and Outer Cal . . . . .	8-9
	Type D - Outer Cals Using the Divide-By-Two Method . . . . .	8-9
8-5	Network Extraction: Type A . . . . .	8-9
8-6	Network Extraction: Type B . . . . .	8-11
8-7	Network Extraction: Type C . . . . .	8-13
8-8	Network Extraction: Type D . . . . .	8-15
8-9	Uncertainty and Sensitivity . . . . .	8-17
8-10	Summary . . . . .	8-20

### Chapter 9—Other Calibration Procedures

9-1	Overview of Other Calibration Procedures . . . . .	9-1
9-2	Through (Thru) Update . . . . .	9-1
9-3	Interpolation . . . . .	9-2

### Chapter 10—Calibration and Measurement Enhancements

10-1	Chapter Overview . . . . .	10-1
10-2	Embedding/De-embedding (E/DE) . . . . .	10-3
	Embedding Tasks . . . . .	10-3
	De-Embedding Tasks . . . . .	10-3
	Embedding On/Off Control . . . . .	10-4
	Types of E/DE Networks . . . . .	10-7
	Entry Mode for Resistive Elements . . . . .	10-8
	Entry Mode for Transmission Lines . . . . .	10-9
	Entry Mode for S2P Defined File-Based Networks . . . . .	10-10
	Saving and Recalling Embedding Network Configuration . . . . .	10-11
10-3	Reference Plane Control . . . . .	10-12
	Auto Button Functions . . . . .	10-12
10-4	Impedance Transformation . . . . .	10-14
10-5	Processing Order . . . . .	10-15
	Reference Plane Processing Sequence . . . . .	10-15
	Group Delay Processing Sequence . . . . .	10-15
10-6	Conversions . . . . .	10-16

## Table of Contents (Continued)

---

### Chapter 11—Measurement Setup Requirements

11-1	Chapter Overview . . . . .	11-1
11-2	Traces Introduction . . . . .	11-1
	Per-System Variables . . . . .	11-1
	Per-Trace Variables . . . . .	11-1
11-3	Channels and the Channel Menu . . . . .	11-2
	Maximum Number of Points Setup . . . . .	11-5
	Channel Variables . . . . .	11-5
11-4	Traces . . . . .	11-6
	Per-Trace Variables . . . . .	11-8
	Complex Trace Setup Example . . . . .	11-10
11-5	Limit Lines . . . . .	11-11
	Limit Test . . . . .	11-11
	Test Result Sign . . . . .	11-11
	Limit Line . . . . .	11-11
	Limit Fail Signal . . . . .	11-11
	Editing of Limit Lines . . . . .	11-12
	Edit Limit Line Menu . . . . .	11-12
11-6	Response Menu . . . . .	11-13
11-7	Averaging and Smoothing . . . . .	11-14
	Overview . . . . .	11-14

### Chapter 12—Measurement - Time Domain (Option 2)

12-1	Chapter Overview . . . . .	12-1
12-2	Introduction . . . . .	12-1
12-3	Basic Time Domain Modes . . . . .	12-2
12-4	General Concepts . . . . .	12-2
	Chirp-Z Transform . . . . .	12-2
	Defects as Impulse Functions in the Time Domain . . . . .	12-2
	One-Way or Round Trip Time . . . . .	12-2
12-5	Low Pass Mode . . . . .	12-3
	Range Setup Menu Functions . . . . .	12-4
	DC Term Menu . . . . .	12-5
	Window Shape Menu . . . . .	12-6
12-6	Bandpass Mode . . . . .	12-10
12-7	Gating . . . . .	12-14
	Gate Menu . . . . .	12-14
	DUT Example - Gate and Window Nominal . . . . .	12-16

### Chapter 13—Measurement - Advanced Time Domain (Option 22)

13-1	Chapter Overview . . . . .	13-1
13-2	Introduction . . . . .	13-1
13-3	Eye Diagram . . . . .	13-2
	Eye Diagram Configuration File . . . . .	13-2
	Eye Diagram Plot and Calculations . . . . .	13-3

## Table of Contents (Continued)

---

13-4	Launching the SI Analysis Tools (ADK mini)	13-4
13-5	Overview of the ADKmini Functions	13-5
	Check Passivity & Causality	13-5
	Combine .SnP Files	13-6
	Plot Eye Diagram	13-7
	Plot Crosstalk	13-9
	Plot TDR, TDT & Skew	13-10
	Perform Compliance Test	13-11
13-6	Example Measurement	13-12
13-7	Summary	13-12
13-8	Signal Integrity Acronyms	13-13

### Chapter 14—Measurement - Sweep Types

14-1	Chapter Overview	14-1
14-2	Introduction	14-1
	Sweep Configuration	14-1
	Sweep Types	14-1
14-3	Setting Up Traditional Frequency Sweeps (Linear and Log)	14-2
	ALC Entry Field	14-3
	Effective Power Field	14-3
	Target Power Field:	14-3
	Example	14-3
14-4	Setting Up Power Sweeps	14-5
14-5	Frequency-Based Segmented Sweep	14-7
14-6	Index-Based Segmented Sweep	14-11

### Chapter 15—Reciprocal Measurements

15-1	Chapter Overview	15-1
15-2	Introduction	15-1
15-3	Line Length Estimate	15-2
15-4	SOLR Calibration	15-2
15-5	Uncertainty and Sensitivity Considerations	15-3

### Chapter 16—Multiport Measurements

16-1	Introduction to Multiport	16-1
16-2	Shockline™ MS46524B VNA	16-1
	Blocking Test Set Combinations	16-2
16-3	Conventional (Single-Ended) S- and User-Defined Parameters	16-2
16-4	Mixed-Mode Parameters	16-5
	MIXED MODE Dialog Box	16-10

## Table of Contents (Continued)

---

16-5	Calibrations . . . . .	16-14
	Tracking . . . . .	16-15
	Isolation . . . . .	16-15
	New Error Model . . . . .	16-15
	Menus . . . . .	16-16
	Transmission Tracking . . . . .	16-17
	Load Match . . . . .	16-17
	Setting Up the Defined Standards Calibration . . . . .	16-18
	Selecting Possible Throughs . . . . .	16-18
	LRL/LRM Calibrations . . . . .	16-22
	4-Port LRL/LRM Calibrations . . . . .	16-23
	Three Port LRL/LRM Calibration . . . . .	16-24
16-6	Uncertainty . . . . .	16-27
	Uncertainty of Derived Mixed-Mode S-Parameters . . . . .	16-29
16-7	Saving SNP Data Files . . . . .	16-31
16-8	Network Extraction . . . . .	16-34
	Type A Network Extraction . . . . .	16-35
	Type E Network Extraction . . . . .	16-36
	Type F Network Extraction . . . . .	16-38
	Type G Network Extraction . . . . .	16-40
16-9	Summary . . . . .	16-42
16-10	References . . . . .	16-42

### **Chapter 17—mm-Wave Measurements (Option 82)**

17-1	Introduction . . . . .	17-1
17-2	Physical Setup for the MS46522B-082 . . . . .	17-1
17-3	Measurement Tips . . . . .	17-2

### **Chapter 18—E/O and O/E Converter Measurements**

18-1	Chapter Overview . . . . .	18-1
18-2	Introduction and Background . . . . .	18-1
18-3	Measurement Setups and Considerations . . . . .	18-6
	Optical linearity . . . . .	18-6
	Laser power and photodetector bias sequencing . . . . .	18-6
	Optical fiber lengths . . . . .	18-6
	Modulator Bias Control . . . . .	18-7
	Connector care . . . . .	18-7
18-4	Example 2-port Procedures . . . . .	18-8
18-5	Example 4-port Procedures . . . . .	18-13
18-6	Uncertainties . . . . .	18-18
18-7	Summary . . . . .	18-19
18-8	References . . . . .	18-19

### **Chapter 19—Multiple Source Control**

19-1	Overview . . . . .	19-1
------	--------------------	------

---

19-2	Introduction . . . . .	19-1
19-3	Multiple Source Control Set Up. . . . .	19-2
	Four Internal Sources for MS46524B VNAs . . . . .	19-2
	Two Internal Sources for MS46522B VNAs. . . . .	19-2
	Frequency Plan Bands . . . . .	19-2
	Linearly Linked Source Frequencies . . . . .	19-2
	Band Start Frequency, Band Stop Frequency, and Runner Variable f . . . . .	19-2
	MULTIPLE SOURCE Menu. . . . .	19-3
	Defining a Multiple Source Band . . . . .	19-4

**Chapter 20—Maximum Efficiency Analysis (MEA)**

20-1	Chapter Overview . . . . .	20-1
20-2	Introduction and Background . . . . .	20-1
	Software Setup for Maximum Efficiency Analysis . . . . .	20-2

# Chapter 1 — Calibration Overview

## 1-1 Manual Scope

The purpose of this Measurement Guide is to introduce the basic calibration and operation of the ShockLine™ MS46522B/MS46524B Series Vector Network Analyzer (VNA) Systems and reduce the time required to become proficient at performing basic measurements. The procedures in this manual assume a working knowledge of, and a familiarity with, vector network analyzers.

## 1-2 Chapter Summary

This chapter discusses general calibration requirements and the benefits of different calibration types, algorithms, and routines. General calibration setup and measurement procedures are described. Technical references to Anritsu and other calibration-related articles are also presented where appropriate. Some sections provide cross-references to more detailed explanations and procedures in subsequent chapters.

## 1-3 Related Documentation

The following ShockLine™ MS46522B/MS46524B Series Vector Network Analyzers documentation is provided on the user documentation USB flash drive.

### Product Information, Compliance, and Safety

- ShockLine™ Product Information, Compliance, and Safety (PICS) – 10100-00067

### ShockLine™ MS46522B/MS46524B

- MS46522B Series VNA Technical Data Sheet – 11410-00858
- MS46524B Series VNA Technical Data Sheet – 11410-00860
- MS46522B/524B Series VNA Operation Manual – 10410-00743
- MS46522B/524B Series VNA User Interface Reference Manual – 10410-00744
- MS46522B/524B Series VNA Programming Manual – 10410-00746
- MS46522B/524B Series VNA Measurement Guide – 10410-00753
- MS46522B/524B Series VNA User Documentation – 2300-559

### Calibration, Verification, and System Performance Verification

- 365xx-x Mechanical Calibration Kit Reference Manual – 10410-00278

## 1-4 Calibration Kits, Verification Kits, and Components

Anritsu and other vendors provide calibration kits for a variety of algorithms and circumstances. In all cases, certain information must be provided to the VNA in order to complete the calibration, but the nature of that information varies by kit and application.

Calibration kits contain the precision components and tools required to calibrate the ShockLine™ MS46522B/MS46524B Series VNA for up to a complete 12-term error-corrected measurement. The calibration kits are available as manual calibration kits. A set of verification kits is also available to verify the accuracy of the calibration kits and the instrument settings.

### Calibration/Verification Equipment Part Numbers and General Specifications

This table summarizes the equipment related to calibration procedures.

**Table 1-1.** Calibration Equipment Listing (1 of 2)

Part Number	Name	Specifications	Connectors
<b>Precision AutoCal Modules</b>			
36585K-2M	Precision AutoCal Module, K	70 kHz to 40 GHz	K (m) to K (m)
36585K-2F			K (f) to K (f)
36585K-2MF			K (m) to K (f)
<b>Type N Connector Manual Calibration Kits</b>			
3653A	Type N Calibration Kit	With fixed loads	Type N
OSLN50A-8	Precision Mechanical Calibration Tee	Open/Short/Load	N(m)
OSLNF50A-8	Precision Mechanical Calibration Tee	Open/Short/Load	N(f)
TOSLN50A-8	Precision Mechanical Calibration Tee	Through/Open/Short/Load	N(m)
TOSLNF50A-8	Precision Mechanical Calibration Tee	Through/Open/Short/Load	N(f)
<b>SMA Connector Manual Calibration Kits</b>			
3650A	SMA/3.5 mm Calibration Kit	Without sliding loads	SMA/3.5 mm
3650A-1	SMA/3.5 mm Calibration Kit	With sliding loads	SMA/3.5 mm
<b>K Connector Manual Calibration Kits</b>			
3652A	K (2.92 mm) Calibration Kit	Without sliding loads	K
3652A-1	K (2.92 mm) Calibration Kit	With sliding loads	K
TOSLK50A-20	Precision Mechanical Calibration Tee	Through/Open/Short/Load	K(m)
TOSLK50A-20	Precision Mechanical Calibration Tee	Through/Open/Short/Load	K(f)
TOSLK50A-40	Precision Mechanical Calibration Tee	Through/Open/Short/Load	K(m)
TOSLK50A-40	Precision Mechanical Calibration Tee	Through/Open/Short/Load	K(f)
<b>Test Port Cables</b>			
14RKFKF50-0.6	Test port Cable, Armored, Phase Stable, Ruggedized	0.6 m	K(f) to K(f)
14RKFKF50-1.0	Test port Cable, Armored, Phase Stable, Ruggedized	1.0 m	K(f) to K(f)
14RKFK50-0.6	Test Port Cable, Armored, Phase Stable, Ruggedized	0.6 m	K(f) to K(m)
14RKFK50-1.0	Test Port Cable, Armored, Phase Stable, Ruggedized	1.0 m	K(f) to K(m)



Table 1-1. Calibration Equipment Listing (2 of 2)

Part Number	Name	Specifications	Connectors
14KFKF50-0.6	Test Port Cable, Armored, Phase Stable	0.6 m	K(f) to K(f)
14KFKF50-1.0	Test Port Cable, Armored, Phase Stable	1.0 m	K(f) to K(f)
14KFK50-0.6	Test Port Cable, Armored, Phase Stable	0.6 m	K(f) to K(m)
14KFK50-1.0	Test Port Cable, Armored, Phase Stable	1.0 m	K(f) to K(m)
15KK50-1.0A	Test Port Cable, Armored, Phase Stable	1.0 m	K(m) to K(m)
15KKF50-1.0A	Test Port Cable, Armored, Phase Stable	1.0 m	K(m) to K(f)
15LL50-1.0A	Test Port Cable, Armored, Phase Stable	1.0 m	3.5 mm(m) to 3.5 mm(m)
15LLF50-1.0A	Test Port Cable, Armored, Phase Stable	1.0 m	3.5 mm(m) to 3.5 mm(f)
15NNF50-1.0B	Test port Cable, Flexible, Phase Stable	1.0 m	N(f) to N(m)
15NNF50-1.5B	Test Port Cable, Flexible, Phase Stable	1.5 m	N(f) to N(m)
15NN50-1.0B	Test port Cable, Flexible, Phase Stable	1.0 m	N(m) to N(m)
<b>Universal Test Fixtures (UTF) and Right Angle Launchers</b>			
3680-20	UTF, DC to 20 GHz	0.5 cm (min) to 10 cm (max)	3.5 mm (f) to (f)
3680K	UTF, DC to 40 GHz	0.5 cm (min) to 5 cm (max)	K (f) to K (f)
36801K	Right Angle Launcher, DC to 40 GHz	1 cm (min) to 4 cm max	

## 1-5 AutoCal™ Automatic Calibration Modules

The auto calibration process represents both a calibration kit and an algorithm that can be used to speed up the calibration process with extremely high accuracy and a minimal number of manual steps.

The 36585X AutoCal module calibrates the VNA by a process known as “transfer calibration.” There are a number of impedance and transmission states in the module designed to be extremely stable in time and these states are carefully “characterized,” generally by the Anritsu factory but also in a customer laboratory in certain cases. When the same states are re-measured during an actual calibration, and the results compared to the characterization data, an accurate picture can be generated of the behaviors and error terms of the VNA and setup being calibrated.

A very high calibration accuracy is maintained through the use of certain principles:

- The use of many impedance and transmission states.
- The creation of very stable states that are further enhanced with a constant-temperature thermal platform inside the module.
- The use of very reliable and repeatable solid-state switching constructed to provide a great variety of state impedances (for better calibration stability) and clean transmission paths.
- The use of a very careful characterization process that can generate excellent starting data.

The resulting accuracy can exceed that obtained with a typical mechanical calibration performed in a laboratory. The AutoCal results may not be better than that of an exotic manual calibration (such as is performed during factory characterization) but will be far better than that done typically. Since it is a very high performance calibration, connector care is of the utmost importance and is discussed in detail later in this chapter.

The AutoCal consists of the calibration module itself, a separate external power supply, a serial control cable that runs to the VNA, and the characterization data provided on a USB memory device.

A Serial to USB adapter (2000-1809-R) is also required for operating the AutoCal module on a MS46500B series VNA.

### Calibrations Available

Of the various calibration types described for the instrument, most are available with the AutoCal unit. Frequency response calibrations are omitted since the AutoCal unit would provide no benefit in these cases (since only a through or high reflect standard is needed for these calibrations). Available calibrations include:

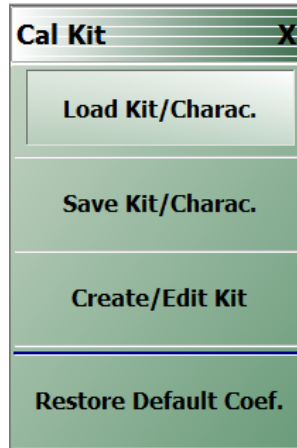
- Full 2-Port calibration
- Reflection only (full 1-Port calibration); either port or both can be specified
- 1-Path 2-Port (1p2p); either direction can be specified (i.e., calibrate  $S_{11}$  and  $S_{21}$  or calibrate  $S_{22}$  and  $S_{12}$ )
- Full 4-Port calibration

## 1-6 SOLT Kits (365xx)

This kit, based on short-open-load-through, require data describing all of the reflection standards (provided by the factory) be loaded into the instrument on a serial number basis. If this media (a USB key) is not available, average default coefficients are available within the VNA that may suffice for some measurements.

Typically these calibration kits are loaded using the CAL KIT/AUTOCAL utility menu ([Figure 1-1](#)) but user-defined kits can also be created using the parameters described above. If calibration kits from another manufacturer are used or to create a calibration kit, the following parameters are typically entered into one of the user-defined kits:

- Open definition (M and F typically)
- Short definition (M and F typically)
- Load definition (M and F typically)



**Figure 1-1.** CAL KIT/AUTOCAL Utility Menu

The CAL KIT/AUTOCAL utility menu is shown here. This menu allows calibration kit details to be loaded from external files (as provided with Anritsu calibration kits), saved to a file (for user-defined cal kits), defaulted (for standard connector types), or simply displayed.

## 1-7 Offset Short Waveguide Kits (3655X)

Waveguide calibration kits based on offset short calibrations are also provided for different waveguide bands. Here two different offset-length shorts (accomplished with flush shorts and two different insert lengths), loads, and a through must be specified. Some of the standard kits are pre-defined and user-defined kits are possible as usual. Additional pieces of information here due to line type are the cutoff frequency and dielectric constant. Items as part of the definition:

- Load definition
- Short 1 definition
- Short 2 definition
- Waveguide cutoff frequency

## 1-8 Microstrip/Coplanar Waveguide Kits for the UTF (36804-XXX)

For certain microstrip and coplanar waveguide measurements, the Universal Test Fixture (UT) can accommodate a range of substrate sizes and thicknesses (see 3680 brochure for more information). The 36804 series of calibration kits provide opens, shorts, loads and a variety of transmission line lengths on alumina that can be used for different calibration algorithms. User-defined kits must be generated based on the information provided with the kits.

## 1-9 On-Wafer Calibration Kits

A variety of calibration standard substrates or impedance standard substrates are available from other vendors that contain opens, shorts, loads, and transmission lines for on-wafer calibrations. A variety of calibration algorithms may be used depending on the application. For the defined-standards calibrations, a user-defined kit will have to be generated.

## 1-10 Calibration Algorithms

The ShockLine MS4652xB series VNA provides for the following calibration methods:

- Short-Open-Load-Through (SOLT) with Fixed or Sliding Load
- Short-Open-Load-Reciprocal (SOLR)
- Reciprocal or Unknown Through Method
- Line-Reflect-Line (LRL) / Line-Reflect-Match (LRM) AutoCal

## 1-11 About Calibration

The most important central concept to making good VNA S-parameter measurements is the calibration of the instrument. The background on calibration mathematics and theory will only be lightly covered in this section; more information is available in Anritsu Application Notes and in the reference literature. While the VNA is a highly linear receiver and has sufficient spectral purity in its sources to make good measurements, there are a number of imperfections that limit measurements done without calibrations:

### Match

Because the VNA is such a broadband instrument, the raw match can be good but not excellent. Even a 20 dB match, which is physically very good, can lead to errors of greater than 1 dB. By correcting for this raw match, the potential error can be greatly reduced.

## Directivity

A key component of a VNA is a directional coupler that allows separation of the signal incident on the DUT from the reflected back from the DUT. While the couplers used in the VNA are of very high quality, there is an amount of coupled signal even when a perfect termination is connected. This is related to directivity and can impact measurements of very small reflection coefficients.

## Frequency Response

While the internal frequency response of the VNA could be calibrated at the factory, any cables connected externally will have some frequency response that must be calibrated out for high quality measurements.

The calibration is a method of correcting for these and other defects. There are an enormous number of possible calibration algorithms and many of them are implemented within the MS4652xB ShockLine Series VNAs. The choice between them is largely determined by the media used, the calibration standards available, and the desired accuracy/effort trade-off. Some of the choices to be made are:

- **Calibration Type**  
Which ports are being corrected and to what level are they being corrected?
- **Calibration Algorithm**  
How is the correction being accomplished?

## Calibration Types

**Table 1-2.** MS4652xB ShockLine Calibration Types

VNA Mode	Type	Parameters Calibrated	Uses
2-Port VNA Mode	Full 2-Port	$S_{11}$ , $S_{12}$ , $S_{21}$ , and $S_{22}$	Most complete calibration
	Full 1-Port	$S_{11}$ or $S_{22}$	Reflection calibration only
	1 Path 2-Port	$S_{11}$ and $S_{21}$ or $S_{22}$ and $S_{12}$	1-Port reflection plus simple transmission (faster, lower transmission accuracy unless DUT very lossy)
	Frequency Response	Any one parameter (or pairs of symmetric parameters such as $S_{12}$ and $S_{21}$ )	Normalization only. Fast, lower accuracy
4-Port VNA Mode	When in 4-Port mode, additional calibration types of 4-Port and 3-Port become available in the CALIBRATION menus with an associated expansion of S-Parameters, User-Defined, and Mixed-Mode options in the RESPONSE menus.		See <a href="#">Chapter 16, "Multiport Measurements"</a>

## Calibration Algorithms

The use of acronyms for the various calibration algorithms is often inconsistent. The following table presents calibration algorithm acronyms as used in Anritsu documentation.

**Table 1-3.** Calibration Algorithms

Calibration Algorithm	Description	Advantages	Disadvantages
SOLT (Short-Open-Load-Through)	Common coaxially	Simple, redundant standards; not band-limited	Requires very well-defined standards, poor on-wafer, lower accuracy at high frequencies
SOLR, like above but with “Reciprocal” instead of “Through”	Like the above but when a good through is not available	Does not require well-defined through	Some accuracy degradation but slightly less definition, other disadvantages of parent cal
LRL (Line-Reflect-Line, also called Through-Reflect-Line or TRL)	High performance coax, waveguide or on-wafer	Highest accuracy, minimal standard definition	Requires very good transmission lines, less redundancy so more care is required, band-limited
ALRM, advanced line-reflect-match, simplifies to: LRM (Line-Reflect-Match) or TRM (Through-Reflect-Match)	Relatively high performance	High accuracy, only one line length so easier to fixture/on-wafer, not band-limited usually	Requires load definition. Reflect standard setup may require care depending on load model used

The following table relates the Calibration Types to the Calibration Algorithms.

**Table 1-4.** Calibration Types and Calibration Algorithms

VNA Mode	Type	SOLT	SSLT	SSST	SOLR/SSLR/SSSR	LRL	ALRM
2-Port Mode	Full 2 Port	YES	YES	YES	YES	YES	YES
	Full 1 Port	YES	YES	YES	Can be selected for these types, but the reciprocal nature is not used and will function like the base calibration	–	–
	1 Path 2 Port	YES	YES	YES		–	–
	Frequency Response	YES	YES	YES		–	–
4-Port Mode	The calibration types and modes change when the VNA is in multiport (4-Port) mode. See <a href="#">Chapter 16, “Multiport Measurements”</a> for a discussion of multiport calibration methods and types.						

## 1-12 Calibration Setup

Before proceeding to the calibrations and some of the alternatives available, there are certain instrument setup issues that must be discussed first since they will affect the performance of all calibrations. In almost all cases, the current VNA settings will be used during the calibration so setting up the VNA as desired beforehand will help.

### Frequency Start, Stop, and Number of Points

The Start Frequency, Stop Frequency, and number of points should be decided and set in the VNA before performing a calibration. Segmented sweeps should also be set up in advance if a more custom frequency list is desired.

### IF Bandwidth, Averaging and Power

These parameters control the digital filtering and post-processing that determine the effective noise floor, the amount of trace noise and, in some special cases, the immunity to interfering signals. The trade-off for improved noise performance is slower sweep speed.

- **IF Bandwidth (IFBW)**

Settings of 10 Hz to 500 kHz on the MS46522B/MS46524B are allowed with the RMS trace noise ranging from < 6 m dB at the low end to a few hundred m dB at the high end (for high level signals, more for lower level signals). Sweep time will be roughly proportional with the reciprocal of IFBW once below 100 kHz IFBW.

- **Point-by-Point vs. Sweep-by-Sweep Averaging**

- Point-by-Point averaging incurs additional measurements at each given frequency point and will increase sweep time roughly proportionally. Because the additional measurements are taken at once, the effect is similar to proportional change in IFBW.
- Sweep-by-sweep averaging acquires additional measurements on subsequent sweeps and is better at removing lower frequency variations than point-by-point averaging or IFBW reduction. Sweep-by-sweep averaging is a rolling average so the time to fully stabilize from a sudden DUT change is roughly proportional to the average count.

- **Power**

Port power is somewhat less critical because of the excellent linearity of the MS4652xB ShockLine VNA receivers.

## 1-13 Types of Calibrations

The types of calibrations are defined by what ports are involved and what level of correction is accomplished (see [Table 1-2, “MS4652xB ShockLine Calibration Types”](#) on page 1-7).

### Full 4 Port

This is the most commonly used and most complete calibration involving four ports. All sixteen S-parameters ( $S_{11}$ ,  $S_{12}$ ,  $S_{21}$ ,  $S_{22}$ ,  $S_{13}$ ,  $S_{23}$ ,  $S_{33}$ ,  $S_{31}$ ,  $S_{32}$ ,  $S_{14}$ ,  $S_{24}$ ,  $S_{34}$ ,  $S_{41}$ ,  $S_{42}$ ,  $S_{43}$ , and  $S_{44}$ .) are fully corrected.

### Full 2 Port

This is the most commonly used and most complete calibration involving two ports. All four S-parameters ( $S_{11}$ ,  $S_{12}$ ,  $S_{21}$ , and  $S_{22}$ ) are fully corrected.

### Full 1 Port

A single reflection parameter is fully corrected in this case ( $S_{11}$  or  $S_{22}$ ). Both ports can be covered but only reflection measurements will be corrected. This calibration type is useful for reflection-only measurements including the possibility of doing two reflection-only measurements at the same time.

### 1 Path 2 Port (Forward or Reverse)

In this case, reflection measurements on one port are corrected and one transmission path is partially corrected (load match is not). Here forward means  $S_{11}$  and  $S_{21}$  are covered while reverse means  $S_{12}$  and  $S_{22}$  are covered. This technique may be used when speed is at a premium, only two S-parameters are needed and either the accuracy requirements on the transmission parameter are low or the DUT is very lossy ( $\cong >10\text{-}20$  dB insertion loss).

## Reflection and Transmission Frequency Response

This calibration is essentially a normalization and partially corrects one parameter (although two can be covered within the cal menus). Only the frequency response, or tracking slope, of the parameter is corrected so directivity and match behaviors are not taken into account. This technique is valuable when accuracy requirements are not at a premium and a quick measurement is all that is needed.

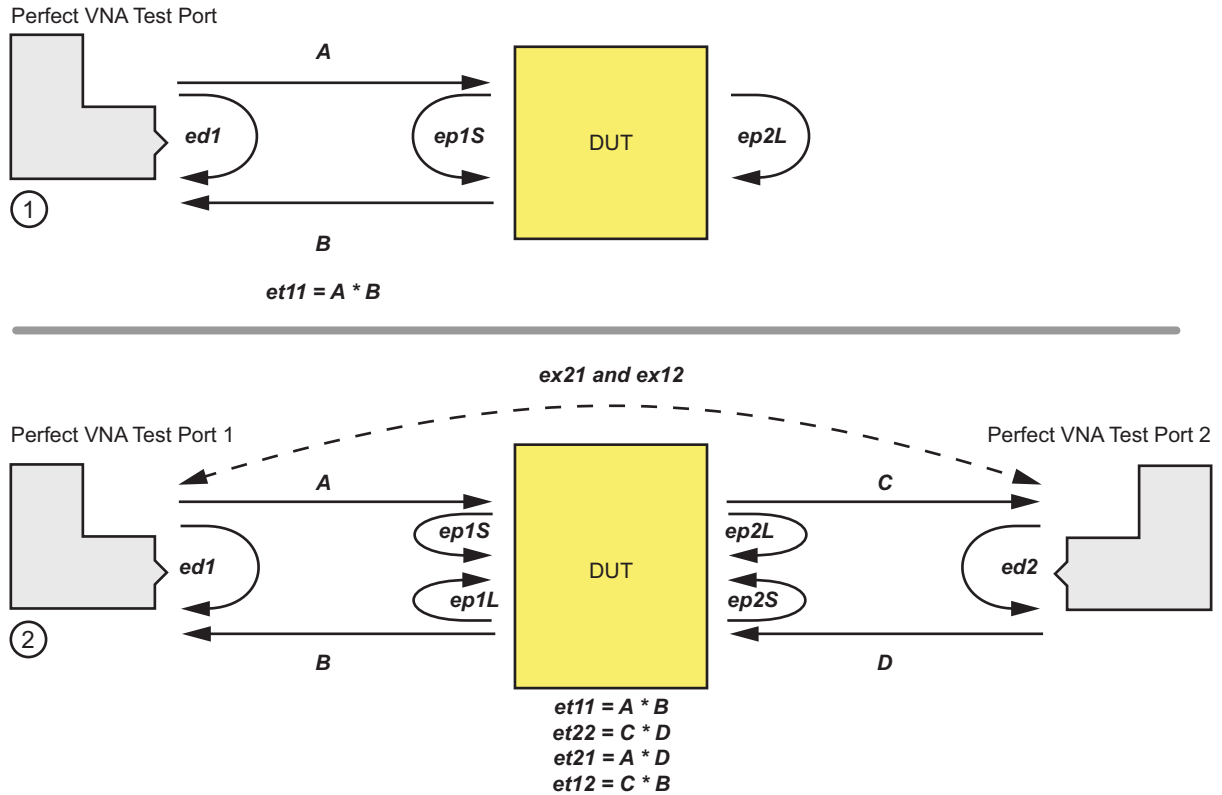
Each of these calibrations has an associated error model that describes what is being corrected. The error coefficients used fall into several categories that roughly describe the physical effect that they are responsible for correcting.

To establish a context for these error terms, consider the usual model where all of the VNA/setup errors are lumped into error boxes (that act like S-parameters) between a perfect VNA and the DUT reference planes (see [Figure 1-2 on page 1-11](#)).

**Note**

The calibration types and modes change when the VNA is in multiport (4-Port) mode. See [Chapter 16, “Multiport Measurements”](#) for a discussion of multiport calibration methods and types.





- |  |  |
|--|--|
| 1. At top, a classic One-Port Error Model. | 2. At bottom, a classic Two-Port Error Model |
|--|--|

**Figure 1-2.** Classic One- and Two-Port Error Models

Two slightly different error models are used: one where each port is considered to be driving separately (so one can clearly delineate source match from load match) and one where both ports are present and no driving distinction is made (requiring some preprocessing to take care of source match-load match differences).

**Directivity:**

Directivity (ed1 and ed2) describes the finite directivity of the bridges or directional couplers in the system. Partially includes some internal mismatch mechanisms that contribute to effective directivity.

**Source Match:**

Source match (ep1S and ep2S) describes the return loss of a driving port.

**Load Match:**

Load match (ep1L and ep2L) describes the return loss of a terminating port. In the 8-term error models used as a basis for the LRL/LRM and other calibration families, this is treated as the same as source match but the incoming data is precorrected to take into account the (measured) difference in match between driving and terminating states.

**Reflection Tracking:**

Reflection tracking (et11 and et22) describes the frequency response of a reflect measurement including loss behaviors due to the couplers, transmission lines, converters, and other components.

**Transmission Tracking:**

Transmission tracking (et12 and et21) is the same as above but for the transmission paths. The tracking terms are not entirely independent and this fact is used in some of the calibration algorithms.

**Isolation:**

Isolation (ex12 and ex21) takes into account certain types of internal (non-DUT dependent) leakages that may be present in hardware. It is largely present for legacy reasons and is rarely used in practice since this type of leakage is typically very small in modern VNAs.

## 1-14 Line Types (Transmission Media)

Part of the calibration definition is the selection of line type. The main purpose of this is to assign a dispersion characteristic that will be needed later. Dispersion is the dependence of the phase velocity on the line with frequency. Media such as coax and coplanar waveguides are largely dispersion-free; that is, we can define phase velocity by a single number:

$$v_{ph} = \frac{c}{\sqrt{\epsilon_r}}$$

= Phase velocity for coaxial and non-dispersive media

### Equation 1-1

Where:

- $c$  is the speed of light in a vacuum (~2.9978108 m/s) and
- $\epsilon_r$  is the relative permittivity of the medium involved.

Coaxial cable has its own selection since it is intrinsic to the instrument while other non-dispersive media can be selected separately.

One type of dispersive media is regular waveguide. The phase velocity here is defined by:

$$v_{ph} = \frac{c}{\sqrt{\epsilon_r} \times \sqrt{1 - \left(\frac{f_c}{f}\right)^2}}$$

$$= \frac{c}{\sqrt{\epsilon_r - \left(\frac{f_{c0}}{f}\right)^2}}$$

= phase velocity for waveguide

### Equation 1-2

Where:

- $\epsilon_r$  is the dielectric constant
- $f_c$  is the cutoff frequency of the waveguide (with dielectric) and
- $f_{c0}$  is the cutoff frequency of the waveguide in a vacuum (which is what is entered).

The system will compute the required values. This information is needed for computing distances when in time domain and when adjusting reference planes.

Microstrip lines are another example of dispersive media that can be selected. Here the dimensions of the line together with the dielectric material determine the phase velocity behavior. An intermediate quantity, called the effective dielectric constant ( $\epsilon_{r,eff}$ ), is used and a suggested value computed by the VNA but this value can be overridden. At low frequencies, the structure can be considered non-dispersive (like coax) with a phase velocity given by:

$$v_{\text{ph}} = \frac{c}{\sqrt{\epsilon_{r, \text{eff}}}}$$

= low frequency limit

### Equation 1-3

At higher frequencies when additional mode behavior becomes important, dispersion must be handled. The dielectric constants (media-based and effective) together with a transition frequency  $f_t$  are used to compute this effect which is heavily dependent on the dielectric thickness:

$$v_{\text{ph}} = \frac{c}{\sqrt{\frac{\epsilon_{r, \text{eff}} + \epsilon_r \cdot \left(\frac{f}{f_t}\right)^2}{1 + \left(\frac{f}{f_t}\right)^2}}} \quad \text{where} \quad f_t = \frac{Z_c \epsilon_0 \sqrt{\epsilon_r} c^2}{2t \sqrt{\epsilon_{r, \text{eff}}}}$$

### Equation 1-4

Where:

- $Z_c$  is the characteristic impedance of the microstrip line
- $t$  is the dielectric thickness

## 1-15 Preparing a Sliding Load (Termination) Calibration Kit

Sliding terminations (loads) are the traditional  $Z_0$  calibration-reference devices for vector network analyzer calibration. When correctly used and perfectly aligned, they can be more accurate than precision fixed loads. However, sliding terminations have a low frequency limit dependent on connector type and must be used with a fixed load for full frequency-range coverage. The connector frequency limits are:

- 26.5 GHz for 3.5 mm Connector sliding loads
- 40 GHz for K Connector sliding loads

Sliding terminations consist of a connector, a long section of precision transmission line, and a microwave load that is movable within the transmission line. Pin depth is the relationship between the interface positions of the outer and center conductors and is the most critical parameter that you can control in a sliding termination. An example of its criticality is that an incorrect pin depth of 0.001 inch can cause a reflection return loss of 44 dB. Since you are usually calibrating to accurately measure a greater than 40 dB return loss, correct pin depth is essential.

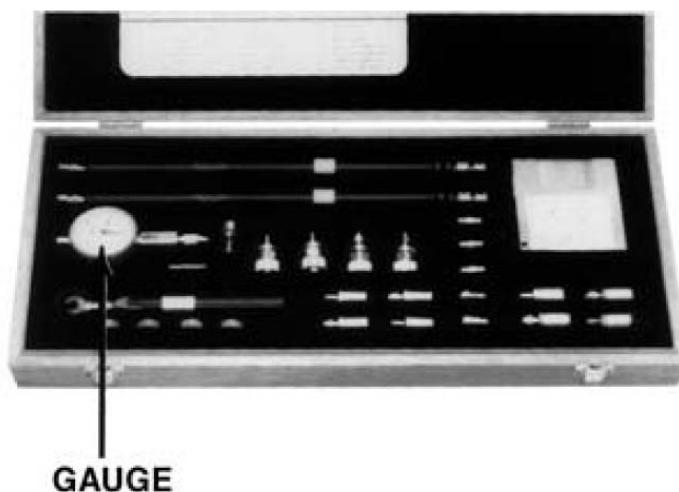
Since setting an accurate pin depth is so important, this discussion centers on describing how to set the pin depth for male and female sliding terminations. Calibration with the sliding termination is essentially the same as described below for the broadband load.

The procedure below uses the Model 3652 Calibration Kit and its 17KF50 and 17K50 Sliding Terminations. Calibration is similar for the Model 3650 SMA/3.5mm Kit

### Procedure

1. Remove the **Pin Depth Gauge** from the kit, place it on the bench top.

**Note** The gauge is convertible between male and female. The following procedure describes the zeroing process for the female fitting. The procedure for the male fitting begins with [Step 16](#) below.



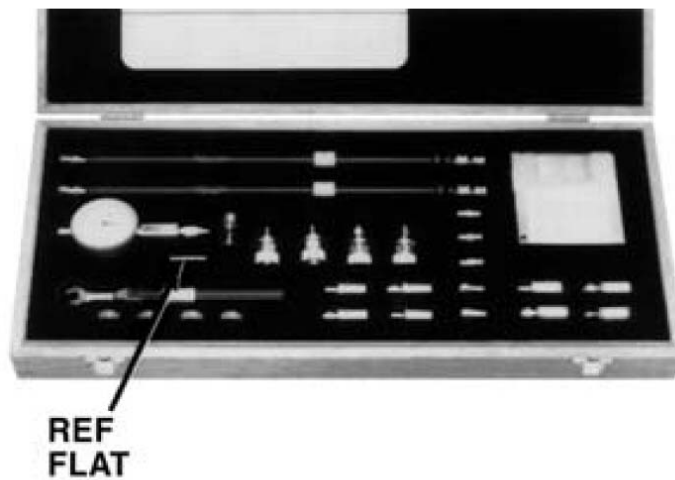
**Figure 1-3.** Calibration Kit

2. Push the outer locking ring towards the gauge to expose the center pin.
- 



**Figure 1-4.** Exposing the Center Pin

3. Take the **01-210 Reference Flat (Ref Flat)** from the kit.
- 



**Figure 1-5.** Reference Flat in Case

4. While holding the gauge as shown, press the **Ref Flat** firmly against the end of the exposed center pin.



**Figure 1-6.** Setting Pointer to “0”

5. While pressing the **Ref Flat** against the center pin, check that the pointer aligns with the “0” mark. If it does not, loosen the bezel lock screw and rotate the bezel to align the pointer with the “0” mark. Tighten the **bezel lock screw**.

**Note**

Gently rock the Ref Flat against the center pin to ensure that it is fully depressed and you have accurately set the gauge for zero.



**Figure 1-7.** Dial Bezel and Pointer at “0”

6. Remove the **Sliding Termination** with the female-connector (17KF50, for this example) from the kit, and slide the load all the way toward the end closest to the connector.



**Figure 1-8.** F-F Sliding Terminator, Towards End Closest to Connector

**Caution**

The center pin of the sliding load is floating. The load should be sighted from the connector end and rotated to allow gravity to pull the center pin such that it is concentric with the outer housing. Note the orientation of the sliding load assembly and ensure this orientation is preserved when making connections to the sliding load to avoid damaging the center pin.

7. With either hand, pick up the sliding termination near its connector end.



**Figure 1-9.** Holding F-F Sliding Terminator

8. Cup the **Sliding Termination** in your palm, and support the barrel between your body and crooked elbow.



**Figure 1-10.** Holding F-F Sliding Terminator, Ready to Measure

9. Remove the **Flush Short** by holding its body and unscrewing its connector.



**Figure 1-11.** F-F Sliding Terminator, Removing Flush Short



10. Ensure that the orientation of the sliding load is such that the center pin is concentric with the outer housing and install the gauge onto the end of the sliding termination.



**Figure 1-12.** F-F Sliding Terminator, Installing Gauge

11. If the factory-set **COARSE SET** adjustment has not moved, the inner dial on the gauge will read "0." If it does not, perform the **Coarse Set Adjustment** in [Step 15](#) below.



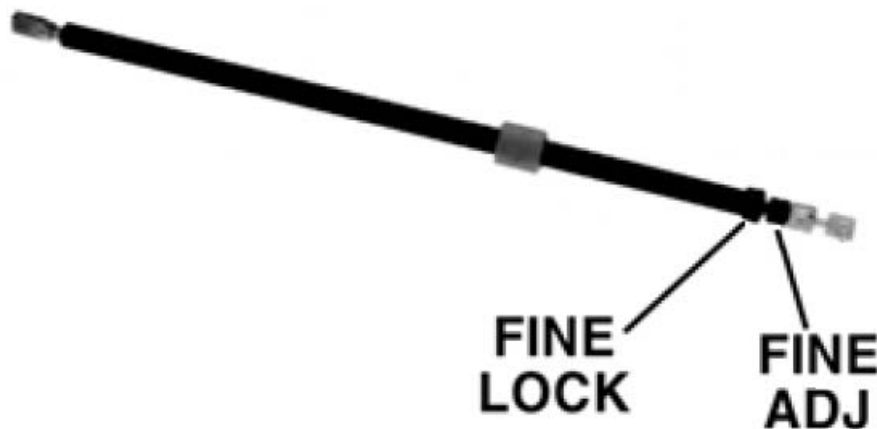
**Figure 1-13.** Gauge Reading, Outer Dial Reading, Inner Dial Reading

- Place the sliding termination, with the gauge attached, on the bench top.



**Figure 1-14.** F-F Sliding Terminator with Attached Dial Gauge

- Loosen the **FINE LOCK** ring and turn the **FINE ADJ** ring to position the gauge pointer 0-3 small divisions on the “-” side of zero. The Sliding Load Pin Depth specification is from 0.000 inches to -0.0003 inches (0.000 in to -0.0003 in).



**Figure 1-15.** Using the Fine Lock Ring and Fine Lock Adjustment

- Turn the **FINE LOCK** ring clockwise to both tighten the adjustment and place the pointer exactly to “0.” The Sliding Termination is now ready to use.

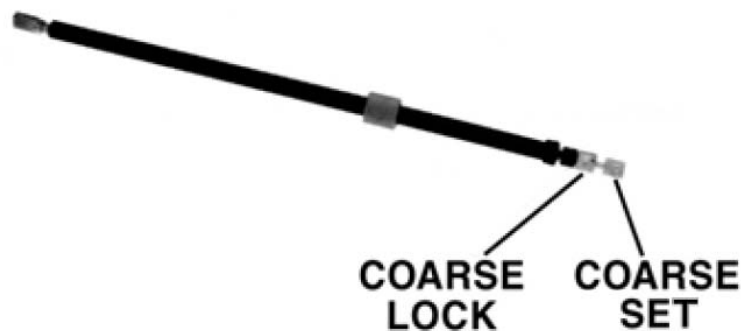
**Note**

Insure that the inner dial reads “0.” The following step is not normally necessary and it needs to be performed only if the adjustment has changed since it was set at the factory.



**Figure 1-16.** Fine Lock Adjustment with Gauge Inner Dial Reading “0”

15. With the **01-211 Flush Short** installed, loosen the **COARSE LOCK** and gently push the **COARSE SET** adjustment rod in as far as it will go. This coarsely sets the center conductor to be flush against the attached short. Return to [Step 2](#) above.



**Figure 1-17.** M-M Sliding Terminator

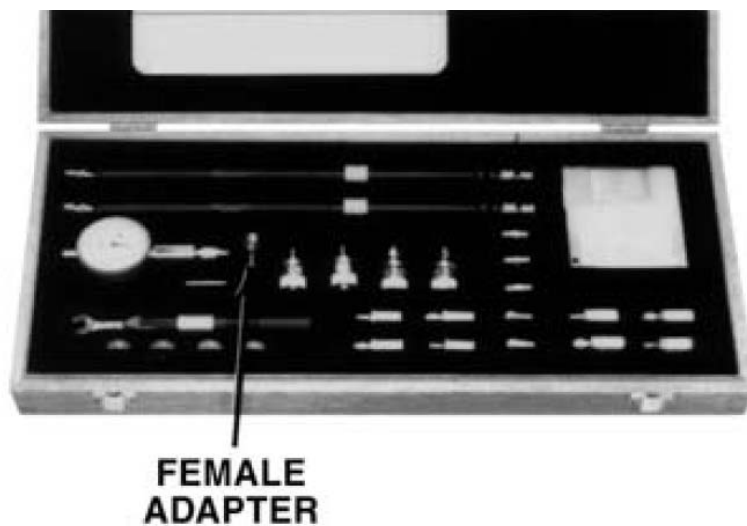
16. The procedure for adjusting the male-connector sliding termination is essentially the same as that described above. The only difference is that you must install the female adapter on the end of the gauge shaft, over the center conductor. To install this adapter, proceed as follows:
  - a. Zero-set the gauge as described in [Step 2](#) through [Step 5](#) above.
  - b. Push the outer locking ring back toward the gauge and turn it clockwise onto the exposed threads.

- c. Loosen the lock ring one turn in a counterclockwise direction.
- 



**Figure 1-18.** Preparing the Gauge for the Female Adapter

- 17. Remove the **01-223 Female Adapter** (“F ADAPTER FOR PIN GAUGE”) from the kit.
- 



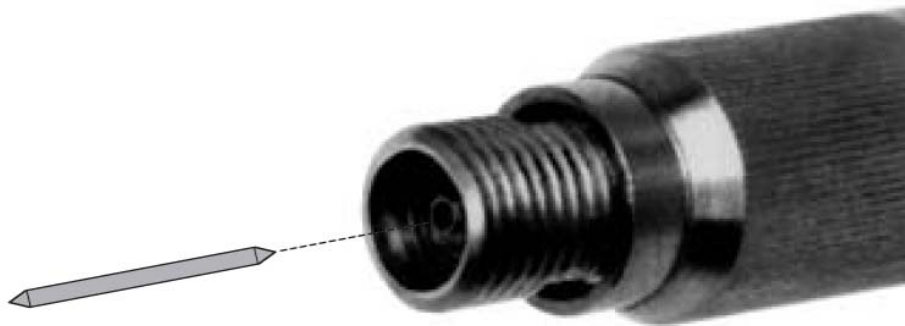
**Figure 1-19.** Female Adapter Location in Case

18. Install the female adapter over the center pin and screw it into the locking ring, and tighten the outer ring until it is snug against the housing.



**Figure 1-20.** Installing the Female Adapter on the Gauge

19. Inspect the end of the adapter, you should see no more than two exposed threads. If so, repeat [Step 7](#) through [Step 10](#) above.



**Figure 1-21.** Inspecting the End of the Female Adapter

20. Insert the **Female Alignment Pin – 7862** as shown in [Figure 1-21](#) to aid in center-pin alignment with the pin-depth gauge.
21. Connect the gauge to the sliding termination and zero set the center pin using the **FINE ADJ** as previously described in [Step 2](#) through [Step 5](#) above.

# 1-16 Connector Precautions

## Pin Depth

Before mating, measure the pin depth (Figure 1-22) of the device that will mate with the RF component, using an **Anritsu Pin Depth Gauge** or equivalent (Figure 1-23). Based on RF components returned for repair, destructive pin depth of mating connectors is the major cause of failure in the field. When an RF component is mated with a connector having a destructive pin depth, damage will likely occur to the RF component connector. (A destructive pin depth has a center pin that is too long with respect to the reference plane of the connector.)

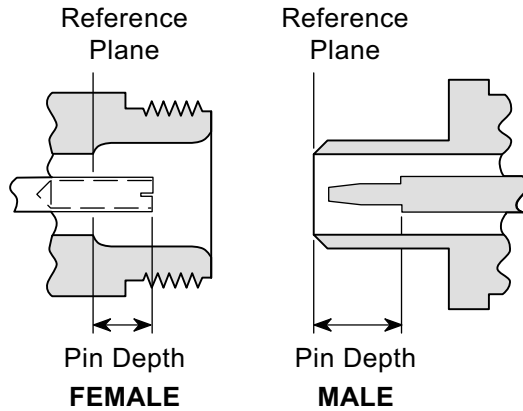
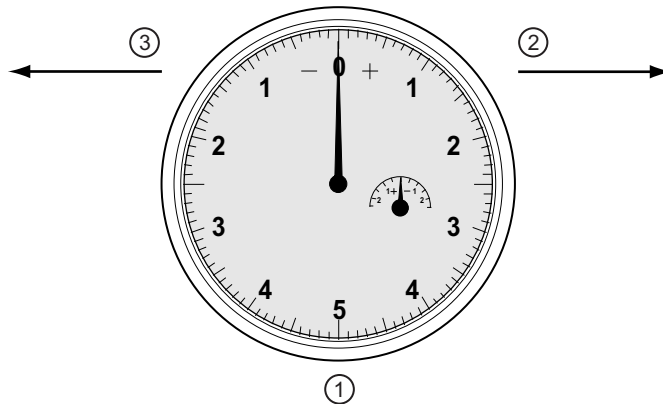


Figure 1-22. N Connector Pin Depth

## Pin Depth Tolerance

The center pin of RF component connectors has a precision tolerance measured in mils (1/1000 inch). Connectors on test devices that mate with RF components may not be precision types and may not have the proper depth. They must be measured before mating to ensure suitability. When gauging pin depth, if the test device connector measures out of tolerance as listed in Table 1-5, “Pin Depth Tolerances” on page 1-25 in the “+” region of the gauge (Figure 1-23), the center pin is too long. Mating under this condition will likely damage the termination connector.



Index	Description
1	Pin Depth Gauge with needle setting at zero.
2	Positive needle direction clockwise to right.
3	Negative needle direction counter-clockwise to left.

Figure 1-23. Pin Depth Gauge

On the other hand, if the test device connector measures out of tolerance in the “–” region, the center pin is too short. While this will not cause any damage, it will result in a poor connection and a consequent degradation in performance.

**Table 1-5.** Pin Depth Tolerances

Connector Type	Pin Depth (Inch)	Pin Depth (mm)
N Male	–0.207	– 5.258
	–0.210	–5.334
N Female	+0.207	+5.258
	+0.204	+5.182
3.5 mm Male	–0.0025	–0.0635
3.5 mm Female	–0.0035	–0.0889
K Male (2.92 mm)	+0.000	+0.000
K Female (2.92 mm)	–0.0050	–0.127

### Over-Torquing Connectors

Over torquing connectors is destructive; it may damage the connector center pin. Finger-tight is usually sufficient, especially on Type N connectors.

<p><b>Caution</b> Never use pliers to tighten connectors.</p>
---

### Teflon Tuning Washers

The center conductor on most RF components contains a small teflon tuning washer located near the point of mating (interface). This washer compensates for minor impedance discontinuities at the interface. The location of the washer is critical to the performance of the RF components.

<p><b>Caution</b> Do not disturb the teflon tuning washer in connectors.</p>
--

### Mechanical Shock

RF components are designed to withstand years of normal bench handling. However, do not drop or otherwise treat them roughly. They are laboratory-quality devices, and like other such devices, they require careful handling.

## 1-17 Connector Cleaning

To prevent unnecessary early failure and inaccurate measurements, connector interfaces must be kept clean and free of dirt and other debris. With repeated connections and disconnections, the threads and outer conductor mating interface builds up a layer of dirt and metal chips which can severely degrade connector electrical and mechanical performance. This debris can also increase the coupling torque required for a good connection which can then damage the mating interfaces.

**Caution** Use the correct sized cotton swabs that are made specifically for cleaning small areas. Oversized cotton swabs can put lateral pressure on the center pin and damage it. Be sure that no cotton strands get caught in the connector.

### Required Cleaning Items

- Low-pressure dry, compressed air (oil free, solvent free), maximum pressure: 40 PSI,
- Lint-free cotton swabs
- Isopropyl alcohol (IPA), 90 %
- Microscope

**Caution** Do not use compressed air on power sensors. Some power sensors have components internally located near the connector that can be damaged from excessive air pressure.

#### Teflon Tuning Washers:

**Note** The center conductor on some RF components contains a small teflon tuning washer located near the point of mating (interface). This washer compensates for minor impedance discontinuities at the interface. The washer's location is critical to the RF component's performance. Be careful not to disturb it with a cotton swab or compressed air and don't apply alcohol to it.

### Cleaning Procedure

Do not use industrial solvents or water to clean the connector. Use 90 % Isopropyl Alcohol (IPA) only.

**Caution** Do not spray alcohol directly onto connector surfaces. Do not saturate the swab with alcohol. Instead, lightly dampen it by touching the tip onto a bead of alcohol formed at the bottle tip as shown.

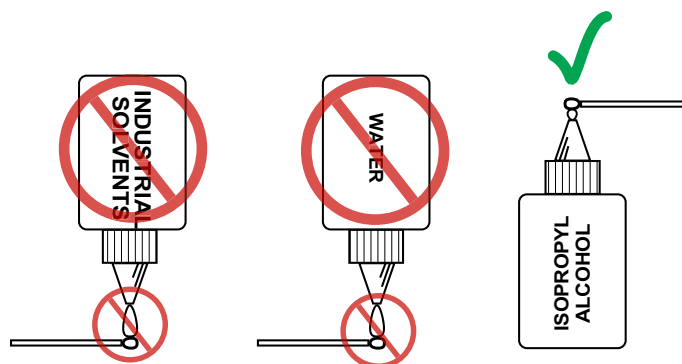
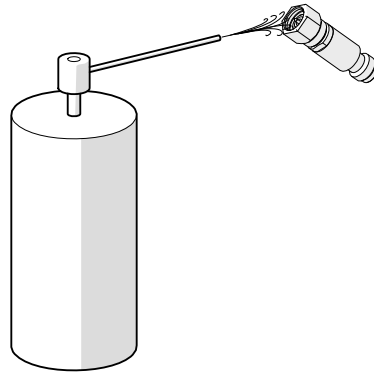


Figure 1-24. Isopropyl Alcohol Only



1. Remove loose particles on the mating surfaces, threads, and similar surfaces using low-pressure (42 PSI max) compressed air applied at a shallow angle so dirt is not forced down into the connector.



**Figure 1-25.** Low Pressure Compressed Air Cleaning

2. Clean the threads of the connector with a lint-free cotton swab dampened with IPA.

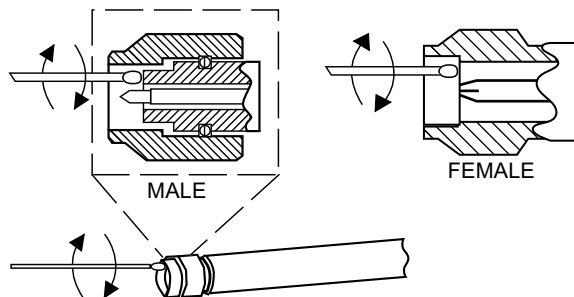
**Caution** Do not insert cotton swabs at an angle. Doing so can damage the center pin. Do not use a cotton swab that is too large. It can stress and damage the center pin.



**Figure 1-26.** Avoid Angled or Large Swab

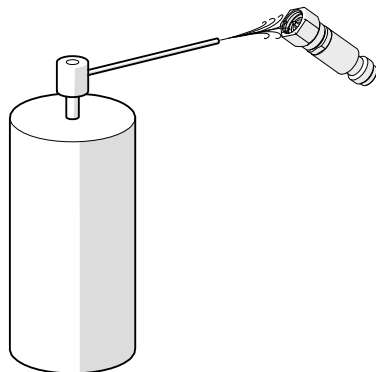
3. Clean the mating plane surfaces and connector threads by gently moving the cotton swab around the center pin. Do *not* touch the center pin.

When the connector is clean, you should be able to hand tighten the connector to within approximately one half turn of the specified torque.



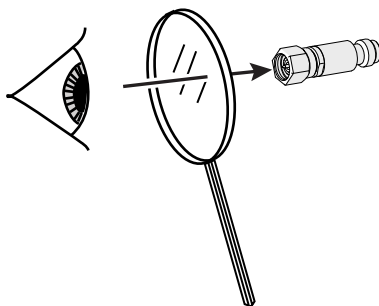
**Figure 1-27.** Cleaning Connector with Cotton Swabs

4. After cleaning with swabs, again use low-pressure compressed air to remove any remaining small particles and dry the connector surfaces.



**Figure 1-28.** Compressed Air Drying

5. With the aid of magnification and adequate lighting, inspect the connectors for damage, cotton strands or other debris.



**Figure 1-29.** Final Inspection

# Chapter 2 — Automatic Calibration

## 2-1 Chapter Overview

This chapter describes common procedures for both Internal Through and True-Through calibration using Anritsu the 36585-Series Precision AutoCal Modules and the MN252x8A SmartCal Modules. This chapter provides two examples of using a precision adapter with an AutoCal and SmartCal unit to create difference-gender reference planes as is adapter removal with an AutoCal and SmartCal unit.

## 2-2 Automatic Calibration Introduction

<b>Note</b>	In some menus and screens, S11 is used to represent the $S_{11}$ calibration parameter, S12 for $S_{12}$ , S21 for $S_{21}$ , and S22 for $S_{22}$ , and so on.
-------------	---

The auto calibration process represents both a calibration kit and an algorithm that is used to speed up the calibration process with extremely high accuracy, minimizing the number of manual steps and test operator involvement.

### Transfer Calibration

The 36585x-Series Precision AutoCal and the MN252x8A SmartCal Module calibrates the VNA by a process known as “transfer calibration.” There are a number of impedance and transmission states in the module designed to be extremely stable in time and these states are carefully “characterized”, generally by the Anritsu factory but also in a customer laboratory in certain cases.

When the same states are re-measured during a calibration, and the results compared to the characterization data, an accurate picture can be generated of the behaviors and error terms of the VNA and setup being calibrated.

### Calibration Accuracy

A very high calibration accuracy is maintained through the use of certain principles

- The use of many impedance and transmission states
- The creation of very stable states that are further enhanced with a constant-temperature thermal platform inside the module.
- The use of very reliable and repeatable solid-state switching constructed to provide a great variety of state impedances (for better calibration stability) and clean transmission paths.
- The use of a very careful characterization process that can generate excellent starting data.

The resulting accuracy can exceed that obtained with typical mechanical calibration typically performed in a metrology laboratory. The automatic calibration results may not be better than that of an calibration performed during factory characterization, but is far better than that typically done.

## 2-3 Automatic Calibration Terms

This section defines various terms used with SmartCal and AutoCal calibration modules and procedures used with the MS4652xB VNA.

<b>Note</b>	Since either module can be utilized in most cases using the same setups described in this chapter, they are referred to as Calibration Modules or Calibrators.
-------------	--

### Insertable and Non-Insertable Devices

Insertable devices have an insertable connector pair such as a male input connector and a female output connector. These devices can be measured after a through calibration. A non-insertable device has a non-insertable pair of connectors such as female connectors on both ports or different connector types such as a DUT with both a K and N connector. Non-insertables cannot be connected directly into the measurement path without an adapter.

- **Through (“Thru”)**

A *thru* (properly called a “through”) is a connection of the two test ports. Two kinds of through connections, internal through and true through, are defined for the Calibration calibration.

- **Internal Through (“Internal Thru”)**

An Internal Through is an internal path through the calibrator requiring no operator involvement in the Calibration Module setup.

- **True Through (“True Thru”)**

A True Through is a direct cable connection between the test ports, with no intervening connectors. An internal through is not as accurate as a true through but requires more operator involvement and takes more time to accomplish. The true through can be more accurate than the internal through (if very well-matched and of very low loss) but the length and loss must be entered. The return loss of the adapters must be very good to avoid added error.

### Auto-Sense

- **AutoCal Module**

A selectable function of the AutoCal module where, if enabled, the AutoCal module decides the left/right test cable assignment. If not enabled, the operator defines the port number to left/right assignment.

- **SmartCal Module**

A selectable function of the SmartCal module where, if enabled, the SmartCal module decides the A/B test cable assignment. If not enabled, the operator defines the port number to A/B assignment.

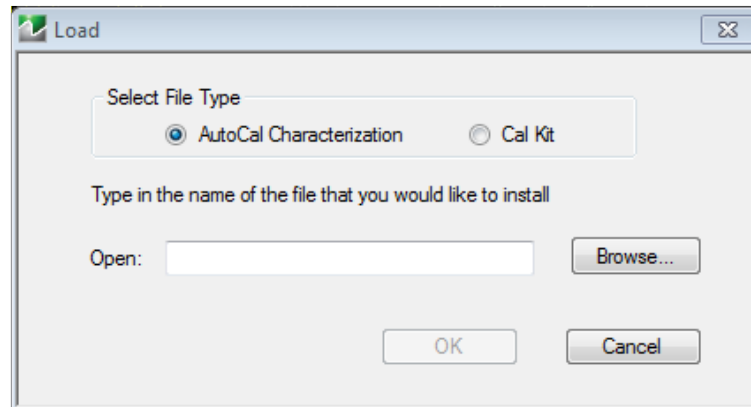
### Characterization File

Each calibrator module has a file containing data which characterizes each standard in the calibrator. This file also contains information (identification number, start and stop frequencies) concerning the capabilities of the calibrator. Each characterization file has the extension “.acd.”

When AutoCal modules are changed, the appropriate new characterization file must be installed. The files are typically stored on a Characterization Memory Device (USB memory device). Insert the Characterization Memory Device into a VNA USB port. This file can be installed by navigating to the INSTALL (AUTOCAL CHARACTERIZATION/CAL KIT) dialog box shown in [Figure 2-1 on page 2-3](#).

- MAIN MENU | Calibration | CALIBRATION | Cal. Kit Options | LOAD KIT / CHARAC. |

Note that when SmartCal modules are changed, there is no need for installing characterization files because all calibration data needed for the SmartCal is located in the SmartCal memory. Simply connect the SmartCal module and it is ready.



**Figure 2-1.** Load CalKit Dialog Box

From the dialog box, navigate to the location of the Characterization Memory Device. Select the file, and copy it to a location within the C:\AnritsuVNA folder. In addition, each calibration module can be re-characterized using the VNA, although specifications are only valid if Anritsu has performed the characterization (recommended re-characterization interval is 12 months). A valid 12-term calibration must be active, which is used to characterize the standards within the module.

## 2-4 Calibrator Modules, Adapters and Features

The two calibrator module models available are the SmartCal Module and the AutoCal Module ([Figure 2-2](#)).



1. MN252x8A SmartCal Module With N Connectors

2. 36585K AutoCal Module With K Connectors

**Figure 2-2.** Automatic Calibration Modules

## AutoCal Description, Modules and Adapters

The AutoCal unit consists of the Calibrator Module itself, a separate external power supply, a control cable that runs to the VNA, and the characterization data that is initially provided on a USB memory device. The AutoCal unit should be powered up and allowed to warm up prior to use (typically a few minutes, the blue Operate LED will illuminate when the unit is at temperature). Allow 90 minutes warm-up time for calibrations. The control cable should be connected to the serial port on the back of the VNA.

The table below shows the available modules.

**Table 2-1.** Precision and Standard AutoCal Kits and Adapters

Part Number	Name	Frequency Range and Connectors
<b>Precision AutoCal Kits</b>		
36585V-Series Precision AutoCal Modules can be used with ShockLine VNAs with adapters. The calibration range is limited to that of the VNA.		
36585K-2M	Precision AutoCal Kit, K (m-m), 2-Port	70 kHz to 40 GHz, K (m) to K (m)
36585K-2F	Precision AutoCal Kit, K (f-f), 2-Port	70 kHz to 40 GHz, K (f) to K (f)
36585K-2MF	Precision AutoCal Kit, K (m-f), 2-Port	70 kHz to 40 GHz, K (m) to K (f)

## SmartCal Description, Modules and Adapters

The SmartCal module is a plug and play device that automatically powers on and loads calibration coefficients from its on-board memory into ShockLine software. SmartCal has auto sense and port mapping features, allowing it to auto sense the VNA port number to which it is connected. In addition, port mapping allows the user to assign any SmartCal port to any of the VNA ports.

**Table 2-2.** SmartCal Automatic Calibration Units

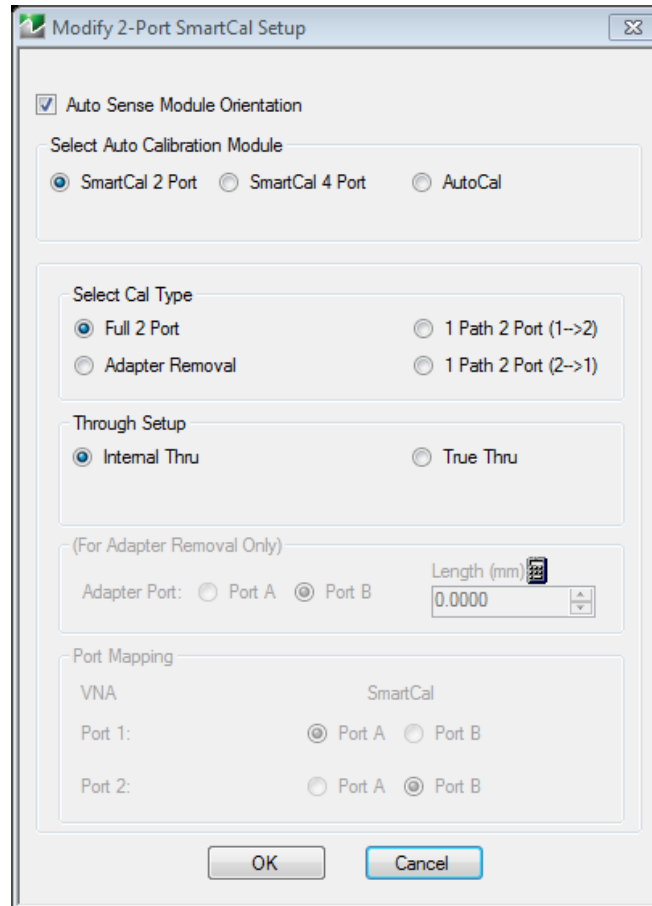
Part Number	Name	Frequency Range and Connectors
<b>Two Port SmartCal</b>		
MN25208A-001	SmartCal Automatic Calibration Unit, N (f-f), 2-Port	300 kHz to 8.5 GHz, N (f) to N (f)
MN25208A-002	SmartCal Automatic Calibration Unit, K (f-f), 2-Port	300 kHz to 8.5 GHz, K (f) to K (f)
MN25208A-003	SmartCal Automatic Calibration Unit, 3.5 mm (f-f), 2-Port	300 kHz to 8.5 GHz, 3.5 mm (f) to 3.5 mm (f)
MN25208A-004	SmartCal Automatic Calibration Unit, SMA (f-f), 2-Port	300 kHz to 8.5 GHz, SMA (f) to SMA (f)
MN25218A-002	SmartCal Automatic Calibration Unit, K (f-f), 2-Port	1 MHz to 20 GHz, K (f) to K (f)
<b>Four Port SmartCal</b>		
MN25408A-001	SmartCal Automatic Calibration Unit, N (f-f), 4-Port	300 kHz to 8.5 GHz, N (f) to N (f)

## Connector Care

Since an automatic calibration is a very high performance calibration, connector care is of the utmost importance. See [Section 1-16 “Connector Precautions” on page 1-24](#) and [Section 1-17 “Connector Cleaning” on page 1-26](#)

## Calibration Parameters and Types

The AutoCal and SmartCal require four general parameters be defined, as shown in the dialog box: [Figure 2-3](#)



**Figure 2-3.** MODIFY 2-PORT SMARTCAL or AUTOCAL SETUP Dialog Box

The parameters are:

- the calibration type required
- the through type to be used
- whether to automatically or manually define the left/right test port assignments
- whether an adapter will be used.

Most standard calibration types are available with the AutoCal units. Frequency response calibrations are the only ones omitted since the SmartCal and AutoCal unit would provide no benefit in these cases since only a through or high reflect standard is needed for these calibrations. The SmartCal and AutoCal modules support:

- Full Two Port (also called Full 2-Port) calibration
- Full Port 1 ( $S_{11}$ ) reflection only calibration
- Full Port 2 ( $S_{22}$ ) reflection only calibration
- 1 Path 2 Port Forward ( $S_{11}$ ,  $S_{21}$ ) calibration
- 1 Path 2 Port Reverse ( $S_{22}$ ,  $S_{12}$ ) calibration

## Adapter Removal

The DUT may require a different connector configuration than is on the current calibrator unit (e.g., F-F DUT and the auto cal is M-F). Adapter removal is one way of handling this situation by performing two auto calibrations with an adapter connected to the AutoCal module (not currently available on SmartCal). The instrument will guide the user through the required connections.

## Through Options

For each calibration type above, there are two Thru calibration options:

- **Internal Thru**

The calibration module provides the internal through connections without the user having to move or reconnect the test cables. The benefit is speed of calibration balanced against potentially less accuracy and accommodates inexperienced operators such as in an assembly line testing station.

- **True Thru**

The calibration modules can also be configured to allow True Thru where the user is prompted when and how to connect the test cables to complete the calibration. The benefit is a higher accuracy calibrations balanced against a longer calibration time and more operator involvement.

## SmartCal Test Port 1 / Port 2 Naming Assignments

The SmartCal module setup allows the user to specify the Port 1,2 identification of the test port cables as either:

- **SmartCal Module Orientation = Port A**

Where the module determines the Port A / Port B identification of the test port cables

- **SmartCal Module Orientation = Port B**

Where the module determines the Port A / Port B identification of the test port cables

## AutoCal Test Port Left/Right Naming Assignments

The AutoCal module setup allows the user to specify the left/right identification of the test port cables as either:

- **Auto Sense Module Orientation = ON**

Where the module determines the left/right identification of the test port cables

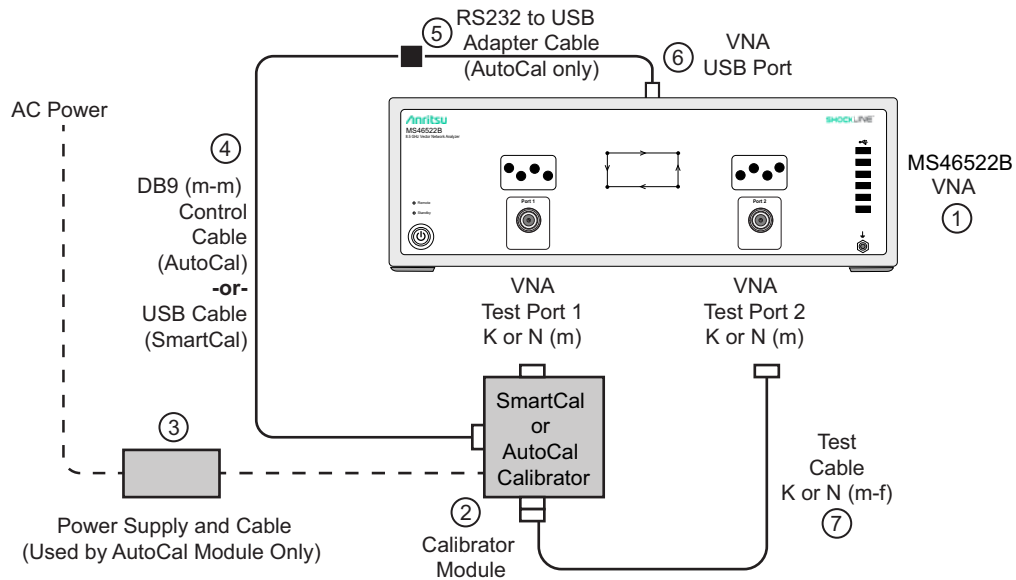
- **Auto Sense Module Orientation = OFF**

Where the user defines either Left = Port 1 and Right = Port 2, or Left = Port 2 and Right = Port 1. This setting is useful where the VNA orientation is different for the operator.



## Typical Calibrator Connections

The typical calibrator connections are shown below in [Figure 2-4](#).

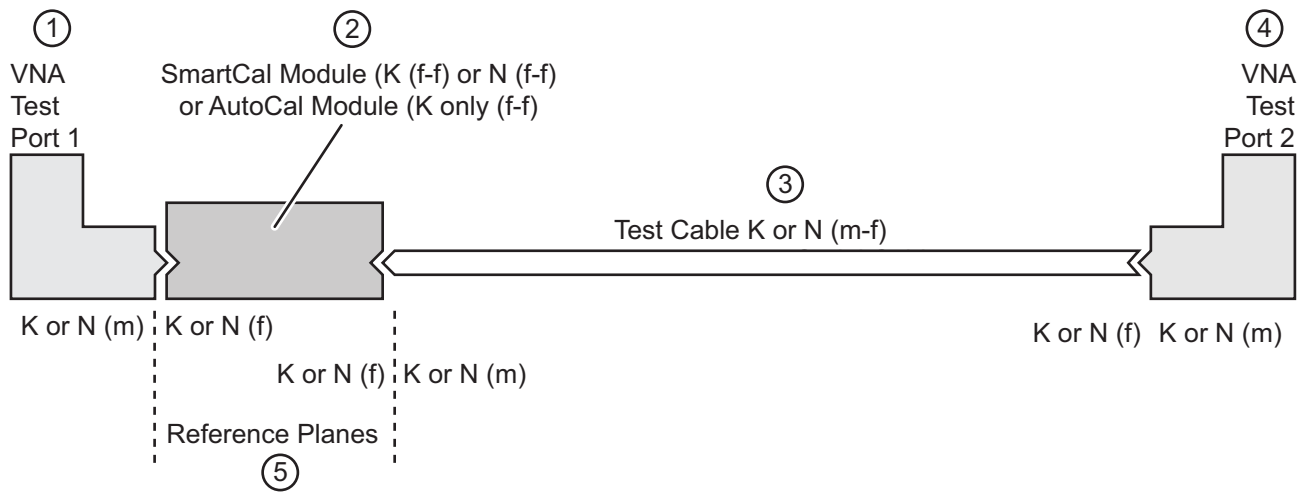


- |   |  |
|---|--|
| <ol style="list-style-type: none"> <li>MS46522B VNA</li> <li>SmartCal (K or N) or AutoCal (K) Calibrator (AutoCal does not support N connectors)</li> <li>AutoCal Power Supply Module with extension able to local AC Mains power (Used with AutoCal module only).</li> </ol> | <ol style="list-style-type: none"> <li>DB9 (m-m) Control Cable (<b>AutoCal</b>) -or- USB Cable (<b>SmartCal</b>)</li> <li><b>AutoCal</b>: RS232 to USB Adapter Cable (2000-1809-R) or USB Cable<br/><b>SmartCal</b>: USB Cable</li> <li>VNA USB Port</li> <li>Test Cable K or N (m-f)</li> </ol> |
|---|--|

**Figure 2-4.** Calibration Module Connections for Internal Through

- Prepare the **MS46522B** and power it up.
- Connect the **Calibration Module** directly to **VNA Test Port 1**.
- The **AutoCal** module is then connected to its **AC Power Supply Module** and it to AC power.  
The **SmartCal** module is powered from the USB of the VNA.
- If using **AutoCal**, connect the **Serial to USB Adapter** between the DB-9 connector on the Calibration Module and the **USB Port** on the MS46522B rear panel.  
If using **SmartCal**, connect the USB cable between the Calibration Module and a USB port on the MS46522B front or rear panel.
- The second **Calibrator** connector is connected to the end of the **Test Cable**. The test cable can be changed depending on measurement requirements. Cables on both VNA ports may be used, different types of cables may be used, or other configurations established. Then connect the end of the **Test Cable** to the **VNA Test Port 2**.

Schematically, this setup is shown in [Figure 2-5](#).



<ol style="list-style-type: none"> <li>1. VNA Test Port 1 with K or N (m) connectors</li> <li>2. SmartCal (K or N) or AutoCal Module (K) (AutoCal does not support N connectors)</li> <li>3. K or N (m-f) Test Cable</li> </ol>	<ol style="list-style-type: none"> <li>4. VNA Test Port 2 with K or N (m) connectors</li> <li>5. Resultant reference planes</li> </ol>
---	--

**Figure 2-5.** Schematic of the Calibrator Connections for Internal Thru

For optimal results, use the shortest cable lengths that do not require excessive bending when performing calibration or measurements. Results will be improved using the most practical phase- and amplitude-stable cables.

The power supply and control cables may be bundled for ease of routing or may be separated for convenience in some cases.

## 2-5 Using the Calibration Module

The calibration procedure can be broken up into several simple steps:

1. Power up the VNA and connect the control cable to the Calibration unit.
2. Install the characterization file if not already done.

<b>Note</b>	The SmartCal Characterization File is provided internally within the SmartCal memory and can be installed directly from that device.  The AutoCal Characterization File (ACD file) is provided on a USB memory device and can be installed directly from that device. These files can also be copied from the USB memory device to the MS4652xB hard drive and installed from there. The preferred method is to copy all ACD files onto the hard drive, and then install the file for the specific AutoCal being used.
-------------	--

3. Setup the Calibrator and the VNA by connecting:

- Calibrator Module directly to one **VNA Test Port**
- A test cable between the Calibrator and **VNA Test Port**
- For **SmartCal**, the USB cable connects between the Calibrator module and the VNA USB port.  
For **AutoCal**, the Serial to USB cable will be placed in the path between the Calibrator module and the VNA USB port.

4. For **SmartCal**, power is supplied through the USB cable.

For **AutoCal**, connect the Calibration module to its power supply and AC power

- For the SmartCal Module, the yellow Power LED illuminates immediately. When the module is recognized, the green Operate LED will illuminate.
- For the AutoCal Module, the green Power LED illuminates immediately. When the module is at operating temperature, the blue Operate LED will illuminate.

5. Setup the VNA instrument for the desired calibration:

- The required minimum settings are Frequency Start, Frequency Stop, and Number of Points.
- If required, optional settings for Segmented Sweep, IF Bandwidth, and/or Averaging are applied.

6. Select the Calibrator parameters of interest and connect the test port cables to the Calibrator unit. Make the required selections for Cal Type, Thru Select, Adapter Removal, and Auto Sense Module.

7. Perform the calibration by clicking **Begin Cal** to start the auto calibration.

8. A status dialog box with a progress bar appears after an Calibration sequence has started. The status messages define how far the program has progressed and if any user actions are required.

9. At any time, the Calibration sequence can be canceled by clicking the dialog box **Abort** button.

10. If any manual steps are requested such as specifying a true-through, a dialog box will prompt for the action.

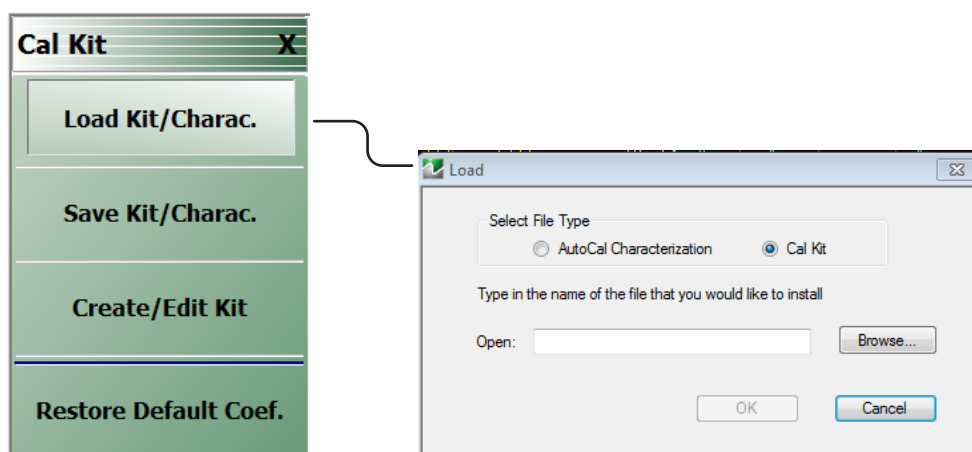
11. When the calibration is complete, a status message appears with a statement about assurance passing or failing. On the Calibration menu, the **Cal Status** field button shows **ON**.

Each procedure is described in greater detail in the following sections.

## 2-6 Copying the Calibrator Characterization File to the MS4652xB (AutoCal Only)

The AutoCal Characterization File (.acd file) is provided on a USB memory device.

1. Inspect the Calibrator kit and make a note of its serial number. Typical Calibrator Kit serial numbers are six-digit integers such as “123456.”
2. Insert the AutoCal Characterization Memory Device (USB memory device) into one of the MS4652xB USB Ports.
3. Navigate to the CAL KIT menu:
  - MAIN | Calibration | Cal Kit Options| CAL KIT



**Figure 2-6.** CAL KIT Utility Menu – INSTALL CHARACTERIZATION FILE Dialog Box

4. On the CAL KIT menu, select Load Kit/Charac. The Install (AutoCal Characterization/CalKit) dialog box appears.
5. Select the AutoCal Characterization radio button and then click Browse. The Open (AutoCal ACD File) dialog box appears.
6. Navigate to the USB port location holding the USB memory device and select the file “v123456 .ACD ,” where “123456” is the serial number of the Calibration kit.
7. Click the dialog box Open button. The Open dialog box closes; the Install dialog box re-appears.
8. Click OK in the Install dialog box. Another install dialog box appears (this one showing the Calibration controller serial number, which is not the module serial number). Click Install in this box close it.
9. On the CAL KIT menu, select Save Kit/Charac. The Save (AutoCal Characterization) dialog box appears. Click OK.
10. Navigate to the required storage directory for the characterization file. The recommended directory destination on the MS4652xB is C:\AnritsuVNA\AutoCal
11. Click Save. The Save dialog box closes, the CAL KIT menu reappears.
12. Repeat the steps above to copy each new Calibration Characterization File to the MS4652xB.

## 2-7 Loading a Previously Stored AutoCal Characterization File

This procedure applies to AutoCal only. Use this procedure if the Calibration Characterization File has already been copied onto the MS4652xB hard drive.

### Procedure

1. Navigate to CAL KIT menu.
  - MAIN | Calibration | CALIBRATION | CalKit Options | CAL KIT
2. On the CAL KIT menu, select Load Kit/Charac.
3. Select the AutoCal Characterization radio button and then click Browse.
4. Navigate to the hard drive (or USB memory device) location of the Calibration Characterization file for the Calibration module in use. The recommended directory destination on the MS4652xB is  
C:\AnritsuVNA\AutoCal
5. Select the Calibration Characterization file, such as “V123456.ACD,” where “123456” is the serial number of the Calibration kit. Click Open.
6. Click OK in the Install dialog box. Another install dialog box appears (this one showing the Calibration Module controller serial number, which is not the module serial number). Click Install in this box close it.
  - The Install dialog box closes and the CAL KIT menu is again available.

## 2-8 Pre-Calibration Instrument Setup

Use this procedure to setup the minimum required instrument configuration parameters:

- Frequency Start
- Frequency Stop
- Number of Points

Any other required measurement parameters must be defined and applied before the Calibration procedure. This section provides a highlight of typical additional measurement parameters.

### Segmented Sweep

If required, segmented sweep must be setup in advance if the calibration needs a custom frequency list. See [“Frequency-Based Segmented Sweep” on page 14-7](#).

### IF Bandwidth (IFBW) and Averaging

IF Bandwidth and Averaging control the digital filtering and post-processing that determine the effective noise floor, the amount of trace noise, and, in some cases, the immunity to interfering signals. The trade-off for improved noise performance is slower sweep speed.

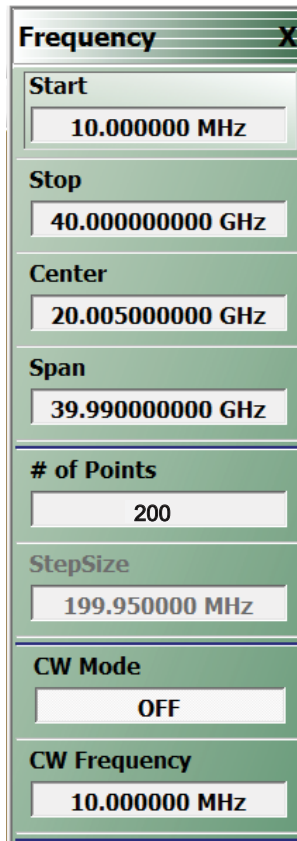
### Port Power

Port power is less critical than IFBW or Averaging due to the excellent linearity of the ShockLine VNA receivers. The Calibration Module unit has an absolute maximum power limit of +10 dBm. The preferred calibration power is -10 dBm for improved accuracy at frequencies <100 MHz.

### Example Procedure

This example procedure assumes the MS4652xB VNA is equipped with the Option 40: 50 kHz to 43.5 GHz and that only Frequency Start, Frequency Stop, Number of Points, and CW Mode settings are required.

1. Determine the values for the minimum setup parameters:
  - Frequency Start: 10 MHz
  - Frequency Stop: 40 GHz
  - Number of Points: 200
  - CW Mode: OFF
  - Segmented Sweep: Not required
  - IFBW: Defaults to 1 kHz
  - Averaging: Defaults to no averaging
2. Power up the MS4652xB and allow it to stabilize its internal temperature.
3. Navigate to the FREQUENCY menu:
  - MAIN | Frequency | FREQUENCY



The screenshot shows a 'Frequency' menu with the following settings:

Parameter	Value
Start	10.000000 MHz
Stop	40.000000000 GHz
Center	20.005000000 GHz
Span	39.990000000 GHz
# of Points	200
StepSize	199.950000 MHz
CW Mode	OFF
CW Frequency	10.000000 MHz

#### 1 – FREQUENCY Menu

**Figure 2-7.** FREQUENCY Menu - Setting Initial Calibration Parameters

4. On the FREQUENCY menu, click the Start frequency button
  - The frequency Start toolbar appears just below the icon toolbar
5. Enter the required start frequency number value.
  - For this example, set the start frequency value at 10 MHz.
6. Enter the required start frequency units.
  - For this example, set the units to megahertz by clicking MHz.
  - The Start frequency field button now shows 10 MHz
7. On the FREQUENCY menu, click the Stop frequency field button
  - The frequency Stop toolbar appears
8. On the Stop frequency toolbar, enter the required frequency number value and units.
  - For this example, set the stop value at 40 and click the GHz units button.
  - The Stop frequency button now shows 40.000000000 GHz
9. The Center and Span display buttons show calculated values based on settings made above
  - The Center frequency field button shows a value of 20.005000000 GHz.
  - The Span frequency field button shows a value of 39.990000000 GHz.
10. On the Frequency menu, click the # of Points (Number of Points) button
  - The # of Points toolbar appears

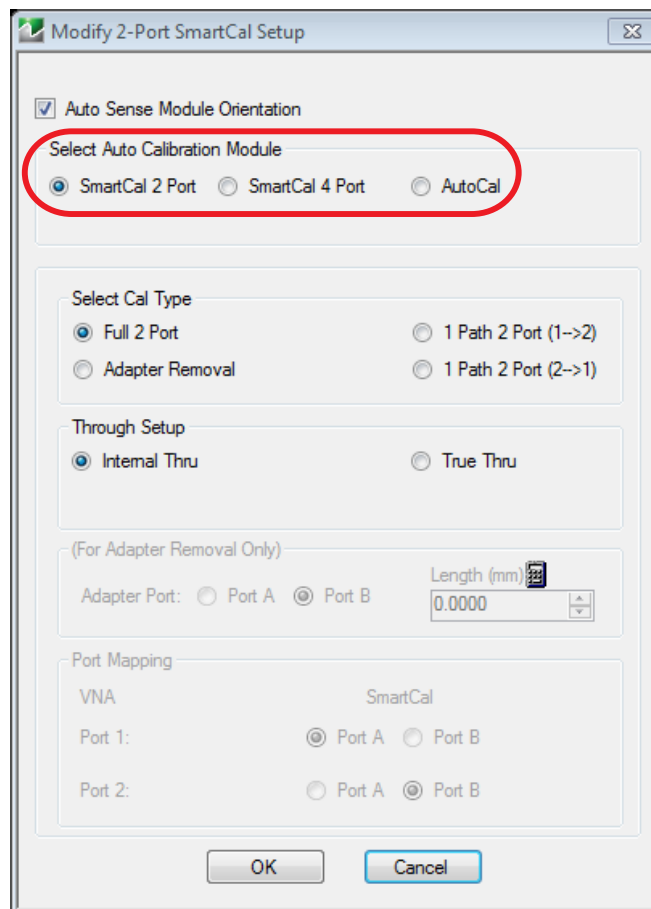
11. On the # of Points toolbar, enter the required number of points.
  - In this example, set the # of Points to 200 and then click Enter on the toolbar.
  - The # of Points field button shows 200
  - The Step Size display button automatically calculates the step size of 199.950000 MHz.
12. Click the CW Mode toggle button so it is set to OFF.
13. If optional parameters are required, do any of the following optional procedures described elsewhere in this manual:
  - [“Frequency-Based Segmented Sweep” on page 14-7.](#)
  - Averaging
  - Power and Attenuation
14. If no optional parameters are required, the Calibration is ready to proceed.
  - [“Calibration – Full Two Port - Internal Through” on page 2-15.](#)



## 2-9 Calibration – Full Two Port - Internal Through

This procedure performs a calibration using a full two port calibration with an internal through, which is sufficiently accurate for most DUTs. When the SmartCal module is plugged into the VNA, the Calibration Characterization file is then loaded onto the VNA.

**Note** The navigational path to the Calibration setup applies to both the SmartCal and AutoCal calibration modules. Make the selection of the calibration module once you navigate through:  
 MAIN | Calibration | CALIBRATION | AutoCal| AUTOCAL | 2-Port Cal | SMARTCAL SETUP |  
 Any selection in the SMARTCAL SETUP menu brings up the menu similar to the one in [Figure 2-8](#). This is where you choose the SmartCal or AutoCal module for your application.



**Figure 2-8.** MODIFY 2-PORT SMARTCAL SETUP DIALOG – SmartCal Selected

### Required Equipment

- MS46522B VNA with K (m) or N (f) test port connectors
- Calibrator Module with K or N (f) connectors and required power and control cables. For AutoCal, the Calibration Characterization File has been loaded onto the MS46522B VNA.
- Test port cable K (f) or N (m) to K (m) or N (m)

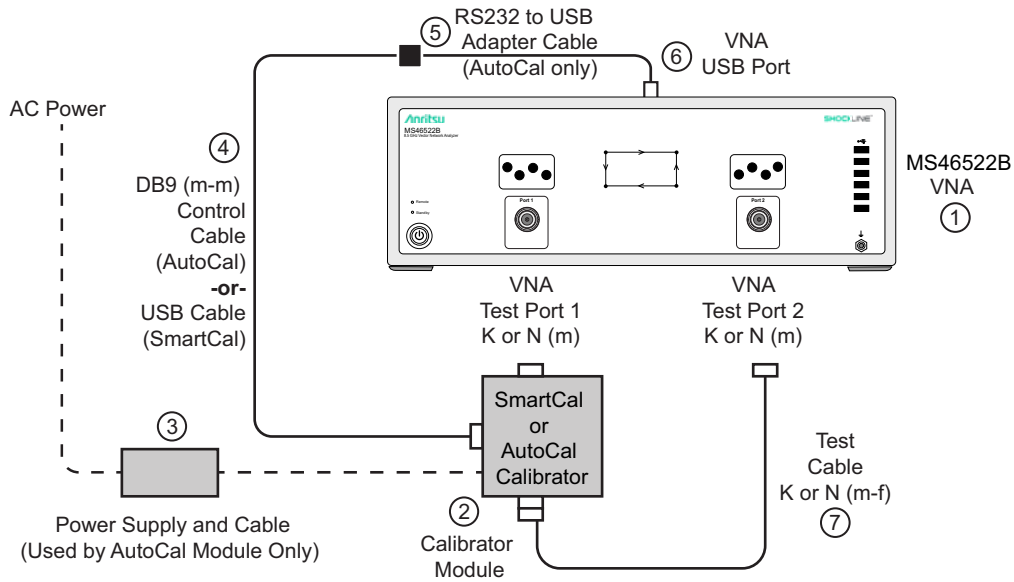
### Procedure

1. Power up the MS46522B VNA.

2. Set the required Frequency Start, Frequency Stop, and Number of Points parameters.
  - See “Pre-Calibration Instrument Setup” on page 2-12.
3. If required, set up other parameters as required such as Segmented Sweep, IFBW, Averaging, and Power and Attenuation.
4. Navigate to CAL KIT menu.
  - MAIN | Calibration | CALIBRATION | AutoCal| AUTOCAL | 2-Port Cal| SMARTCAL SETUP| Thru Type

**Calibrator Module Connections**

5. Connect the **Calibrator** connector directly to the MS46522B **Test Port 1**.
6. If using **AutoCal**, connect the **Serial to USB Adapter** between the DB-9 connector on the Calibration Module and the **USB Port** on the MS46522B rear panel.  
 If using **SmartCal**, connect the USB cable between the Calibration Module and a USB port on the MS46522B front or rear panel.
7. Connect the coaxial power plug from the **Power Supply Module** (AutoCal Module only) to the **AutoCal Module**. (SmartCal is powered by USB.)
8. Once connected to power, the **Calibration Module Power LED** will illuminated green. When the module has warmed up to operating temperature, the **LED** illuminates blue for the **AutoCal Module** and green for the **SmartCal Module**.
9. Connect the **test cable** between **Test Port 2** and the remaining **AutoCal** port.

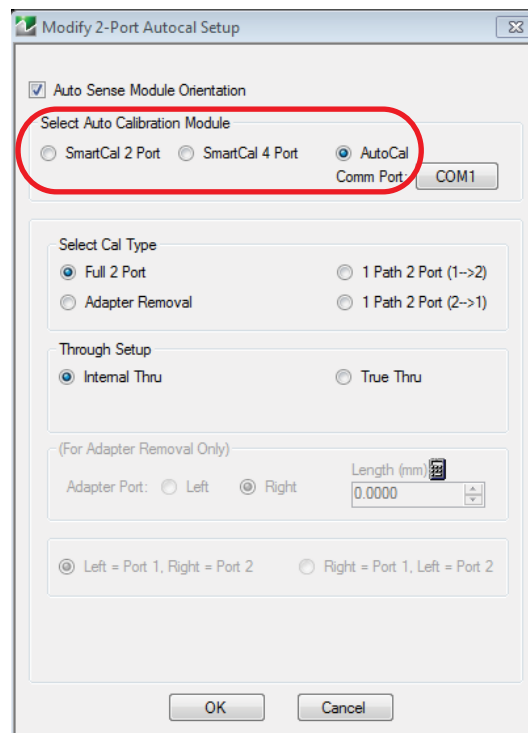


- |   |   |
|---|---|
| <ol style="list-style-type: none"> <li>1. MS46522B VNA with K or N Test Port Connectors</li> <li>2. SmartCal (K or N) or AutoCal (K) Calibrator (AutoCal does not support N connectors)</li> <li>3. AutoCal Power Supply Module (Used with AutoCal module only).</li> </ol> | <ol style="list-style-type: none"> <li>4. DB9 (m-m) Control Cable (<b>AutoCal</b>) -or- USB Cable (<b>SmartCal</b>)</li> <li>5. RS232 to USB Adapter Cable (2000-1809-R) (Autocal only)</li> <li>6. VNA USB Port</li> <li>7. Test Cable K or N (m-f)</li> </ol> |
|---|---|

**Figure 2-9.** Calibrator Cable Connections for Internal Through

10. Navigate to the AUTOCAL SETUP (2-Port) menu:
  - MAIN | Calibration | CALIBRATION | Calibrate | CALIBRATE | AutoCal | AUTOCAL | 2-Port Cal | AUTOCAL SETUP (2-Port)

11. On the AUTOCAL SETUP (2-Port) menu, if the Port Selection, Cal Type, Thru Type, and Module Orientation display buttons do not show the correct values, click the Modify Cal Setup button.
  - The MODIFY AUTOCAL SETUP dialog box appears. The exact name depends on the VNA mode and the user selections for the number of ports. The dialog box can be named:
    - MODIFY 1-PORT AUTOCAL SETUP dialog box
    - MODIFY 2-PORT AUTOCAL SETUP dialog box
    - MODIFY 4-PORT AUTOCAL SETUP dialog box
12. In this example, the required settings are for a Full 2 Port Calibration, with Auto Sense Module Orientation ON, and Internal Through while running on a VNA in 2-Port Mode. The resultant configuration dialog box is names MODIFY 2-PORT AUTOCAL SETUP.

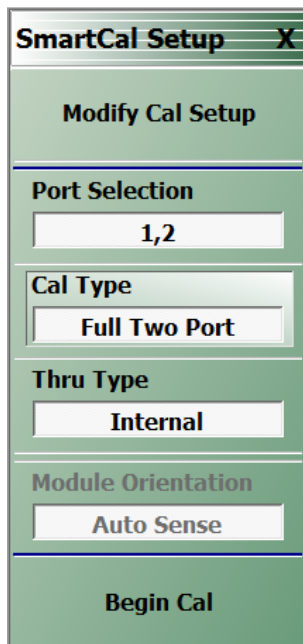


**Figure 2-10.** MODIFY 2-PORT AUTOCAL SETUP Dialog – AutoCal Selected

13. On the MODIFY 2-PORT AUTOCAL SETUP dialog box, select the settings:
  - a. Cal Type Select area: Select the Full Two Port radio button.
  - b. Thru Select area: Select the Internal Thru radio button.
  - c. Auto Sense Module Orientation check box selected: Allows the AutoCal module to determine left/right cable identification or the SmartCal Port A/B cable identification.
  - d. When the settings are complete, select OK to close the dialog box.
14. The AUTOCAL SETUP (2-Port) menu reappears with new values for Cal Type, Thru Type, and Module Orientation.
15. The window area at the bottom of the instrument display area appears with general instructions:
  - a. Ensure correct cable connections to Calibration module.
  - b. Ensure that the **Power** and **Operate LEDs** are both illuminated.
  - c. Ensure characterization file is loaded before starting Cal. To load characterization file, go to the LOAD (AUTOCAL CHARACTERIZATION) dialog box.

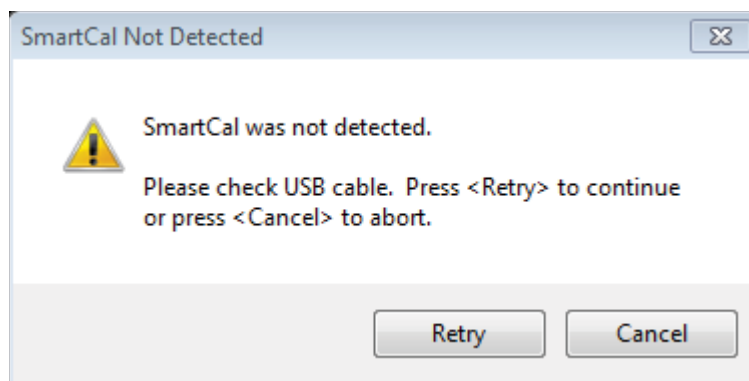
- MAIN | Calibration | CALIBRATION | CalKit Options | CAL KIT | Load Kit/Charc. | LOAD (AUTOCAL CHARACTERIZATION)

d. Existing system setups such as averaging, power level, etc. will be applied during the cal.



**Figure 2-11.** Configured SmartCal 2-Port Menu Setup

16. When ready, click the **Begin Cal** button.
17. If the Calibration module is connected incorrectly, the SMARTCAL MODULE NOT DETECTED warning message appears.
  - Correct the connections as required and click **Retry**.



**Figure 2-12.** If the Calibration module is connected incorrectly, the AUTOCAL MODULE NOT DETECTED warning message appears. Correct connections as required and click the **Retry** button.

**Note**

A different dialog box may appear if the RF cables are connected incorrectly (with Autosense on) that states that Autosense was unable to determine the orientation of the module. If this dialog appears, and a large amount of loss is not present between the port and the Calibration module, check the connections. If a known large amount of loss is present (from the test fixtures or the use of very long cables), the orientation should be manually entered.

18. When the calibration is complete, the **Status Message** dialog box will close and the display will return to the **CALIBRATION** menu with the **Cal Status** button set to **ON**. The assurance dialog will remain up with the pass/fail message, and must be manually closed.

## 2-10 Calibration – Two Port Cal - True Through

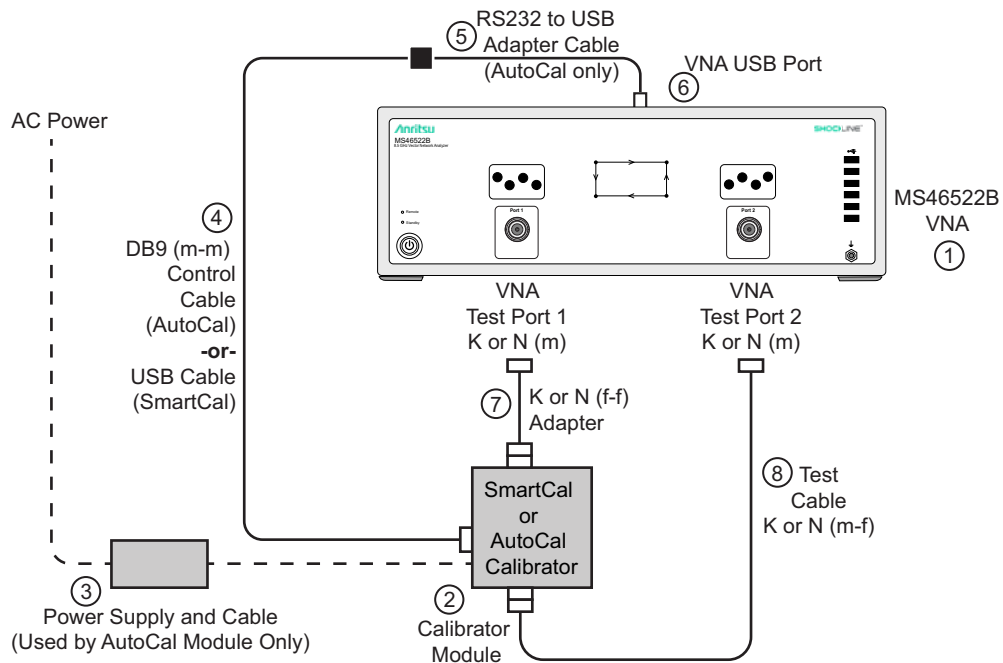
This procedure performs a Calibrator procedure using a full two port calibration where a True Through (or external through) is required.

### Required Equipment

- MS46522B VNA with K (m) or N (f) test port connectors
- Calibrator Module with K or N (with (f) and (m) connectors) and required power and control cables. For AutoCal, the Calibration Characterization File has been loaded onto the MS46522B VNA.
- Test port cable K or N (f) to K or N (m)
- Test port cable K or N (f) to K or N (f), or a K or N (f) to K or N (f) adapter.

### Procedure

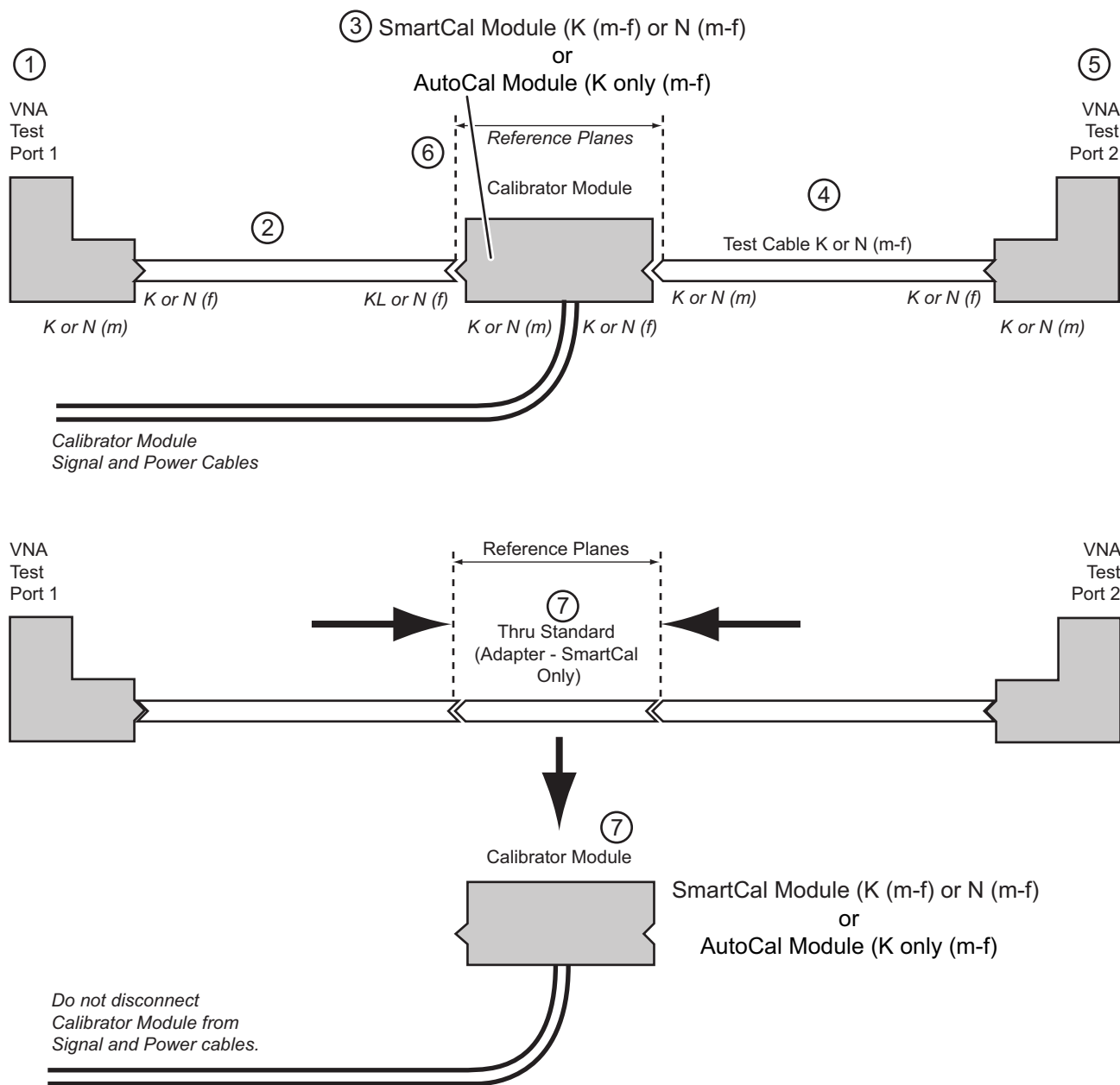
1. Power up the MS46522B.
2. Set the required Frequency Start, Frequency Stop, and Number of Points parameters.
  - [“Pre-Calibration Instrument Setup” on page 2-12.](#)
3. If required, set up other parameters as required such as Segmented Sweep, IFBW, Averaging, and Power and Attenuation.
4. Make the necessary cable connections between the **Calibrator Module** and the **MS46522B** ([Figure 2-13 on page 2-21](#)):
  - a. Connect the **Test Cable** between Test Port 2 and the Calibrator port.
  - b. Connect the **Test Cable** between Test Port 1 and the Calibrator port.
  - c. If using **AutoCal**, connect the **Serial to USB Adapter** between the DB-9 connector on the Calibration Module and the **USB Port** on the MS46522B rear panel.  
If using **SmartCal**, connect the USB cable between the Calibration Module and a USB port on the MS46522B front or rear panel.
  - d. Connect the **coaxial power plug** on the Power Supply Module (AutoCal Module only) to the AutoCal Module and the other end to AC power.
5. Once connected to power, the **Power LED** illuminates as green. When the Calibration module has warmed up, the **LED** illuminates as blue.



- |  |  |
|--|--|
| 1. MS46522B VNA with K or N (m) Test Port Connectors                                   | 4. DB9 (m-m) Control Cable ( <b>AutoCal</b> ) -or- USB Cable ( <b>SmartCal</b> ) |
| 2. SmartCal (K or N) or AutoCal (K) Calibrator (AutoCal does not support N connectors) | 5. RS232 to USB Adapter Cable (2000-1809-R)                                      |
| 3. AutoCal Power Supply Module connected to AC Power (Used with AutoCal module only).  | 6. VNA USB Port  |
|  | 7. K or N (f-f) Adapter connected to VNA Test Port 1                             |
|  | 8. K or N (m-f) Test Cable connected to VNA Test Port 2                          |

**Figure 2-13.** Calibrator Cable Connections for True Through

Schematically, the connections shown in Figure 2-13 above are shown in Figure 2-14.



**Part 1 – Calibration True Thru Procedure**

1. VNA Test Port 1 – K or N (m) Connector
2. K or N (f-f) Test Cable
3. SmartCal (K or N) or AutoCal (K) Calibrator (AutoCal does not support N connectors)
4. K or N (m-f) Test Cable

**Part 2 – Calibration True Thru Procedure**

5. VNA Test Port 2 – K or N (m) Connector
6. Resultant reference planes during first Calibration procedure.
7. After initial calibrations, user is directed to remove Calibration module and connect test cables.  
**Note:** For SmartCal, the Thru adapter is required.
8. Connect the two Test Cables together to complete the through calibration.

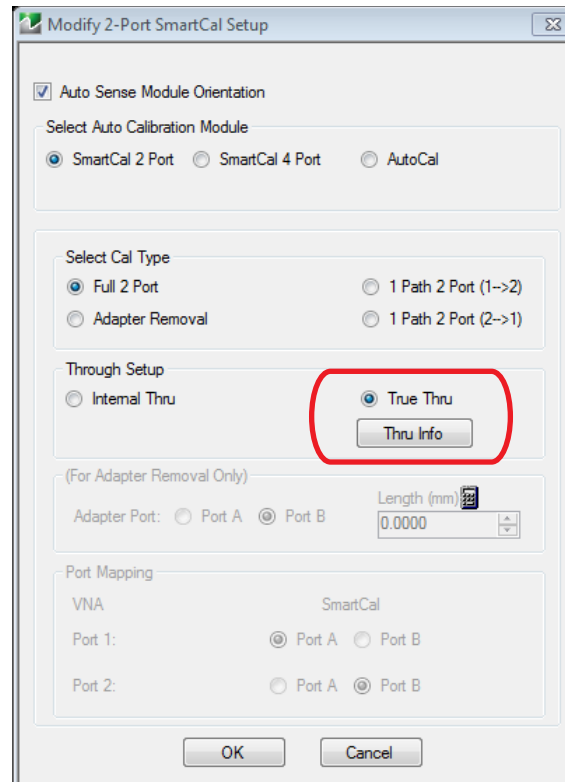
**Figure 2-14.** Calibration Module True-Through Connections



6. Navigate to the AUTOCAL SETUP menu:

- MAIN | Calibration | CALIBRATION | Calibrate | CALIBRATE | AutoCal | AUTOCAL PORTS | 2-Port Cal | SMARTCAL SETUP

7. On the AUTOCAL SETUP menu, if the Cal Type, Thru Type, and Module Orientation display buttons do not show the correct values, select the Modify Cal Setup button.



**Figure 2-15.** True Thru Selected

- The MODIFY 2-PORT AUTOCAL SETUP dialog box appears.
- Change the settings as required.
- In the Cal Type Select area: Select the Full Two Port radio button.
- In the Thru Select area, select THRU INFO dialog box appears.
- Enter information about the through line. Enter 0 length and 0 dB/mm loss (and a reference frequency of 0, which forces it to use that loss at all frequencies) and 50 ohm impedance. Select OK to close the dialog box.
- Select the Auto Sense Module Orientation check box
- Click OK to close the dialog box.

**Note** All existing system setups such as IF Bandwidth, Averaging, and Power Level will be applied during the calibration procedure.

8. When ready, click the Begin Cal button.

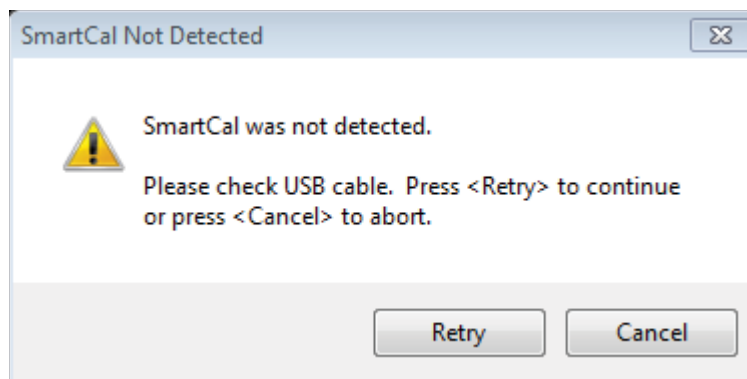
9. A status dialog box with a progress bar appears after an Calibration sequence has started.

The status messages define how far the program has progressed and if any user actions are required.

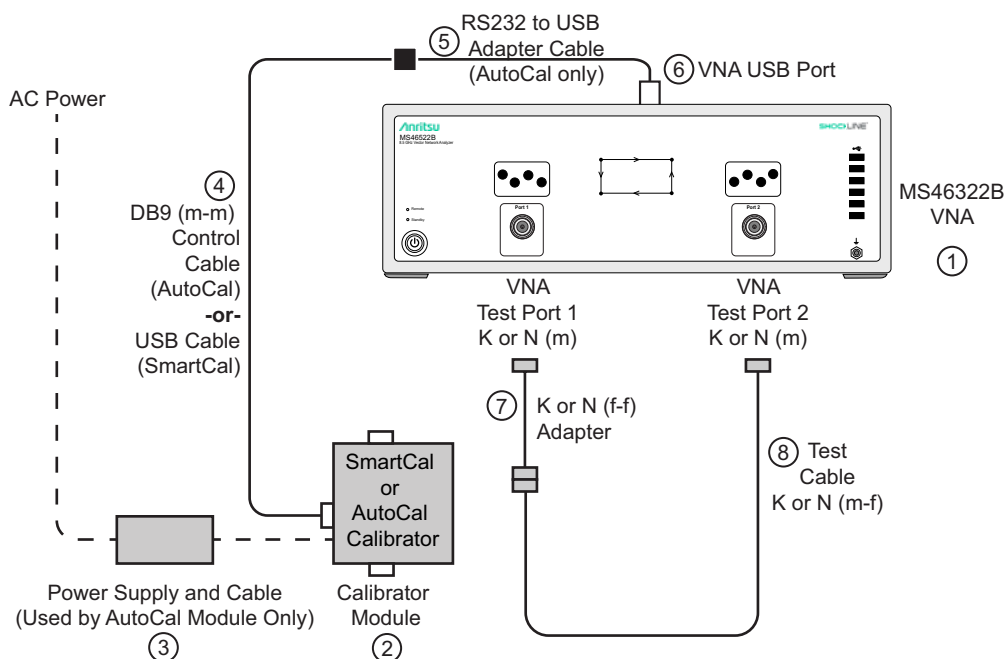
10. At any time, the Calibration sequence can be canceled by clicking the dialog box Abort button.

11. A dialog box will appear when the true through is to be connected.

12. Connect the **Test Port 1 test cable** to the **Test Port 2 test cable**.



**Figure 2-16.** If the Calibration module is connected incorrectly, the SmartCal MODULE NOT DETECTED warning message appears. Correct connections as required and click the Retry button.



- |  |  |
|--|--|
| 1. ShockLine VNA with K or N Test Port Connectors  | 4. DB9 (m-m) Control Cable ( <b>AutoCal</b> ) -or- USB Cable ( <b>SmartCal</b> ) |
| 2. SmartCal (K or N) or AutoCal (K) Calibrator (AutoCal does not support N connectors)   | 5. RS232 to USB Adapter Cable (2000-1809-R)                                      |
| 3. AutoCal Module Power Supply connected to AC Power. (Used with AutoCal module only.) At all times during the calibration procedure, the AutoCal module must be connected to the VNA and to AC power. | 6. VNA USB Port  |
|  | 7. K or N (f-f) Adapter connected to VNA Test Port 1                             |
|  | 8. K or N (m-f) Test Cable connected to VNA Test Port 2                          |

**Figure 2-17.** True-Through Connections - Module Removed

13. After connecting the through, select Continue.

14. When the auto calibration is complete, a status message appears with a statement about assurance passing or failing. On the CALIBRATION menu, the Cal Status field button shows ON.

15. Closing the dialog box returns to the CALIBRATION menu.

## 2-11 Calibration – Full Four Port - Internal Through

Using a SmartCal module, this procedure performs a calibration using a full four port calibration with an internal through, which is sufficiently accurate for most DUTs.

The navigational path to the Calibration setup applies to both the SmartCal and AutoCal calibration modules. Make the selection of the calibration module once you navigate through:

**Note** MAIN | Calibration | CALIBRATION | AutoCal| AUTOCAL | 2-Port Cal | SMARTCAL SETUP |  
Any selection in the SMARTCAL SETUP menu brings up the menu similar to the one in [Figure 2-18](#). This is where you choose the SmartCal or AutoCal module for your application.

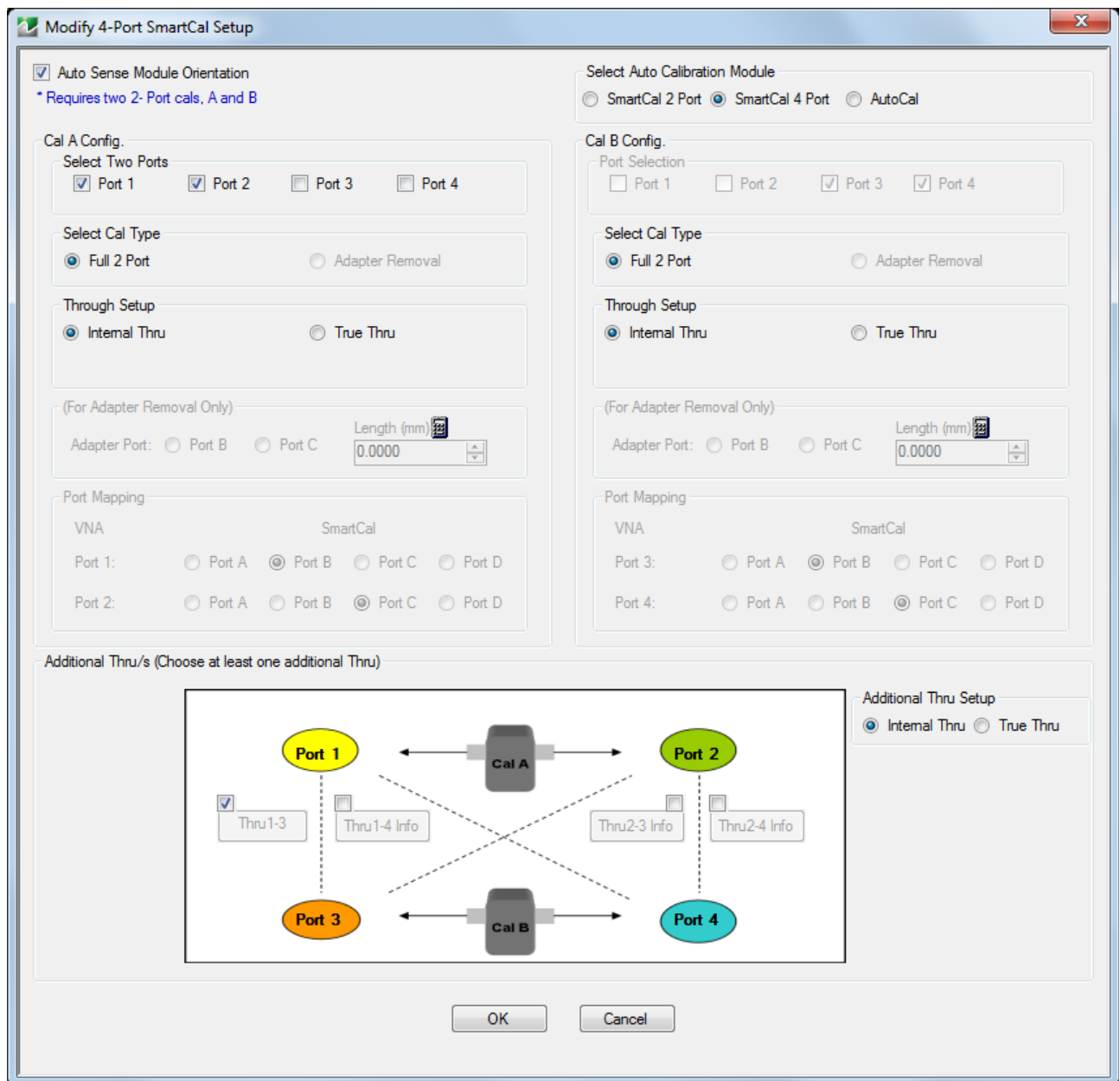


Figure 2-18. MODIFY 4-PORT SMARTCAL SETUP DIALOG – SmartCal 4-Port Selected

## Required Equipment

- MS46524B VNA with K or N test port connectors.
- SmartCal Calibrator Module with K or N connectors and required power and control cables.
- Test port cable, K or N (f-m)

### Note

AutoCal does not come as a 4 port calibrator but a 4 port calibration can be done as two 2-port calibrations. However, SmartCal is available with a 4-port calibrator option.

## Procedure

1. Power up the MS46524B VNA.
2. Set the required Frequency Start, Frequency Stop, and Number of Points parameters.
  - See “Pre-Calibration Instrument Setup” on page 2-12.
3. If required, set up other parameters as required such as Segmented Sweep, IFBW, Averaging, and Power and Attenuation.
4. Navigate to SmartCal Setup menu and dialog.
  - MAIN | Calibration | CALIBRATION | AutoCal| AUTOCAL | 4-Port Cal | SMARTCAL SETUP | Modify Cal Setup | Modify 4-Port SmartCal Setup dialog

## Calibrator Module Connections

5. Make the necessary cable connections between the **Calibrator Module** and the **MS46524B**:
  - a. Connect the **Test Cables** between the VNA Test Ports and the Calibrator ports.
  - b. Connect the **USB Cable** between the Calibration Module and the **USB Port** on the MS46524B front or rear panel.
6. Once connected to power, the **Calibration Module Power LED** will illuminated green on the **SmartCal Module**.

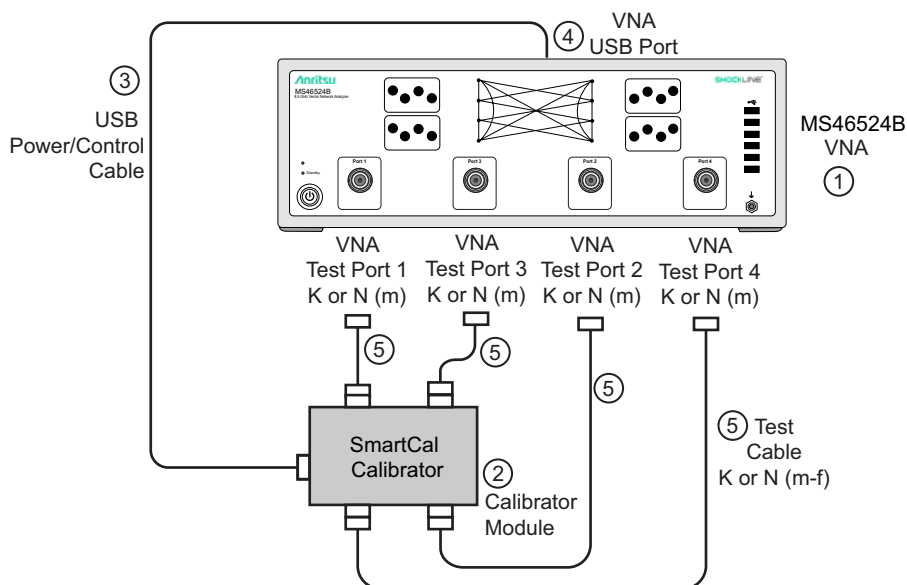


Figure 2-19. Calibrator Cable Connections for Internal Through (1 of 2)

<p><b>Note:</b> Typical connections. Calibrator ports can be connected in any configuration.</p> <ol style="list-style-type: none"><li>1. MS46524B VNA with K or N Test Port Connectors</li><li>2. SmartCal (K or N)</li><li>3. USB Power/Control cable</li></ol>	<ol style="list-style-type: none"><li>4. VNA USB Port</li><li>5. K or N (m-f) Test Cable connected to VNA Test Port 2</li></ol>
---	---

**Figure 2-19.** Calibrator Cable Connections for Internal Through (2 of 2)

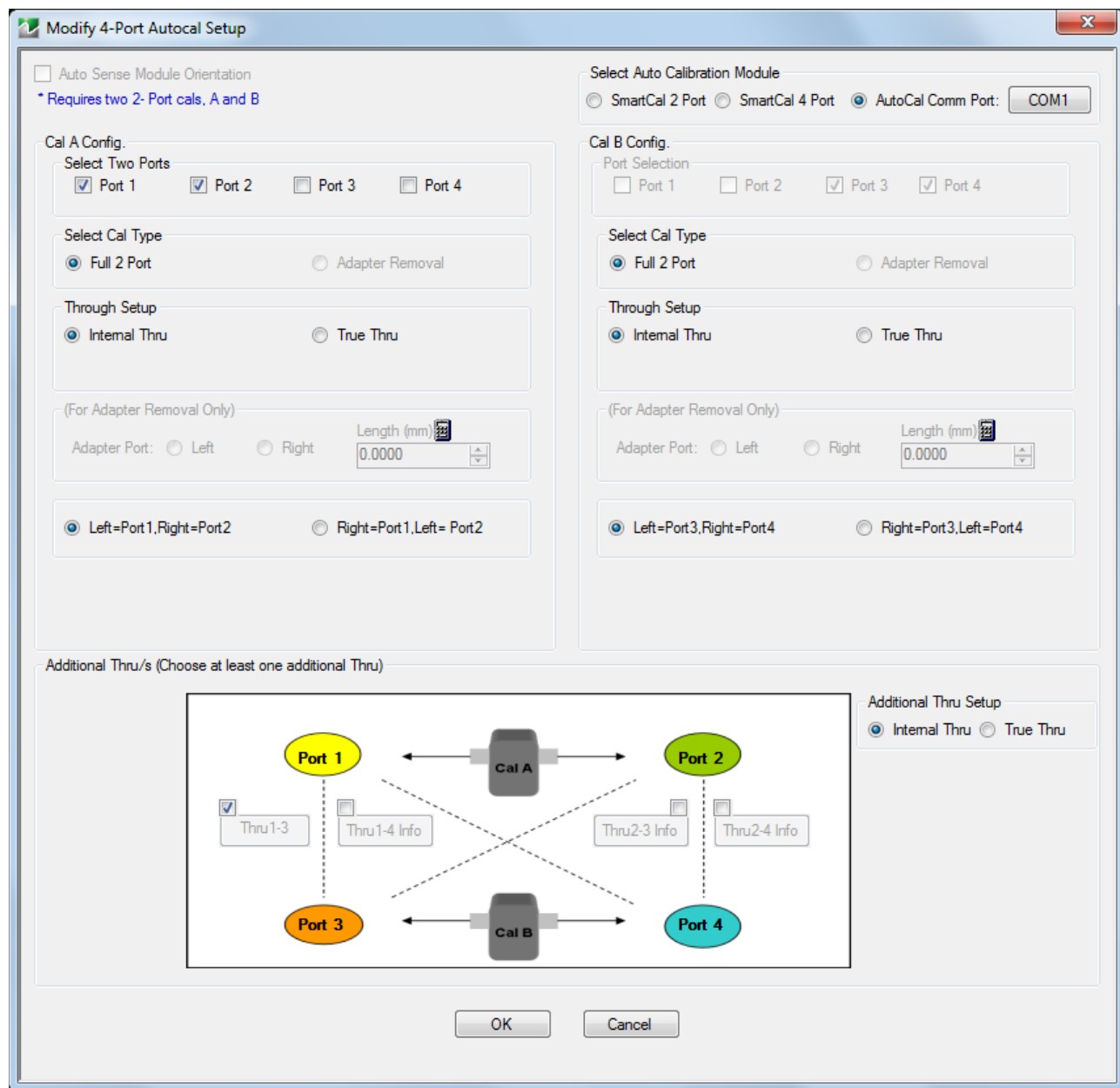
7. Navigate to the AUTOCAL SETUP (2-Port) menu:

- MAIN | Calibration | CALIBRATION | Calibrate | CALIBRATE | AutoCal | AUTOCAL | 2-Port Cal | AUTOCAL SETUP (2-Port)

8. On the AUTOCAL SETUP (2-Port) menu, if the Port Selection, Cal Type, Thru Type, and Module Orientation display buttons do not show the correct values, click the Modify Cal Setup button.

- The MODIFY AUTOCAL SETUP dialog box appears. The exact name depends on the VNA mode and the user selections for the number of ports. The dialog box can be named:
  - MODIFY 1-PORT AUTOCAL SETUP dialog box
  - MODIFY 2-PORT AUTOCAL SETUP dialog box
  - MODIFY 4-PORT AUTOCAL SETUP dialog box

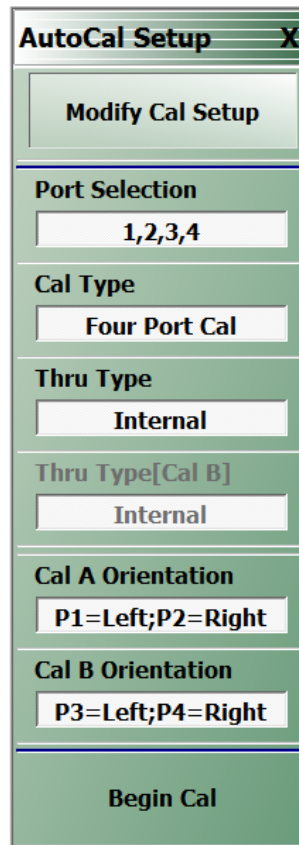
9. In this example, the required settings are for a Full 2 Port Calibration, with Auto Sense Module Orientation ON, and Internal Through while running on a VNA in 2-Port Mode. The resultant configuration dialog box is names MODIFY 4-PORT AUTOCAL SETUP.



**Figure 2-20.** MODIFY 4-PORT AUTOCAL SETUP Dialog – AutoCal Selected

10. On the MODIFY 4-PORT AUTOCAL SETUP dialog box, select the settings:
- Cal Type Select area: Select the Full Two Port radio button.
  - Thru Select area: Select the Internal Thru radio button.
  - Auto Sense Module Orientation check box selected: Allows the AutoCal module to determine left/right cable identification or the SmartCal Port A/B cable identification.
  - When the settings are complete, select OK to close the dialog box.

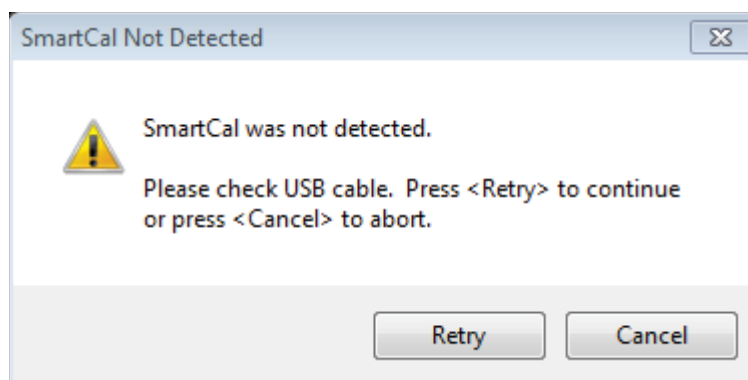
11. The AUTOCAL SETUP (2-Port) menu reappears with new values for Cal Type, Thru Type, and Module Orientation.
12. The window area at the bottom of the instrument display area appears with general instructions:
  - a. Ensure correct cable connections to Calibration module.
  - b. Ensure that the **Power** and **Operate LEDs** are both illuminated.
  - c. Ensure characterization file is loaded before starting Cal. To load characterization file, go to the LOAD (AUTOCAL CHARACTERIZATION) dialog box.
    - MAIN | Calibration | CALIBRATION | CalKit Options | CAL KIT |Load Kit/Charc. | LOAD (AUTOCAL CHARACTERIZATION)
  - d. Existing system setups such as averaging, power level, etc. will be applied during the cal.



**Figure 2-21.** Configured SmartCal 2-Port Menu Setup

13. When ready, click the **Begin Cal** button.
14. If the Calibration module is connected incorrectly, the SMARTCAL MODULE NOT DETECTED warning message appears.

- Correct the connections as required and click Retry.



**Figure 2-22.** If the Calibration module is connected incorrectly, the AUTOCAL MODULE NOT DETECTED warning message appears. Correct connections as required and click the Retry button.

**Note**

A different dialog box may appear if the RF cables are connected incorrectly (with Autosense on) that states that Autosense was unable to determine the orientation of the module. If this dialog appears, and a large amount of loss is not present between the port and the Calibration module, check the connections. If a known large amount of loss is present (from the test fixtures or the use of very long cables), the orientation should be manually entered.

15. When the calibration is complete, the Status Message dialog box will close and the display will return to the CALIBRATION menu with the Cal Status button set to ON. The assurance dialog will remain up with the pass/fail message, and must be manually closed.



## 2-12 Calibration – Four Port Cal - True Through

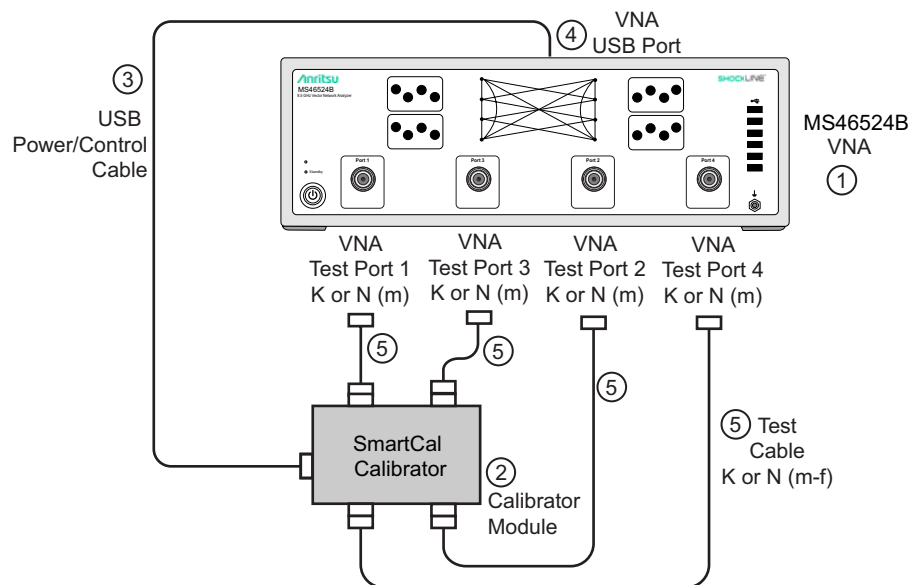
This procedure performs a Calibrator procedure using a full four port calibration where a True Through (or external through) is required.

### Required Equipment

- MS46524B VNAs with K or N (m) test port connectors.
- SmartCal Calibrator Module, with K or N connectors and required power and control cables.
- Test port cable with K or N (f-m) connectors
- Test port cable with K or N (f-f) connectors, or, a K or N (f-f) adapter.

### Procedure

1. Power up the MS46524B.
2. Set the required Frequency Start, Frequency Stop, and Number of Points parameters.
  - “Pre-Calibration Instrument Setup” on page 2-12.
3. If required, set up other parameters as required such as Segmented Sweep, IFBW, Averaging, and Power and Attenuation.
4. Make the necessary cable connections between the **Calibrator Module** and the **MS46524B**:
  - a. Connect the **Test Cables** between VNA Test Ports and the Calibrator ports.
  - b. Connect the **USB Cable** between the Calibration Module and the **USB Port** on the MS46524B front or rear panel.
5. Once connected to power, the **Power LED** illuminates as green.



**Note:** Typical connections. Calibrator ports can be connected in any configuration.

1. MS46524B VNA with K or N Test Port Connectors
2. SmartCal (K or N)

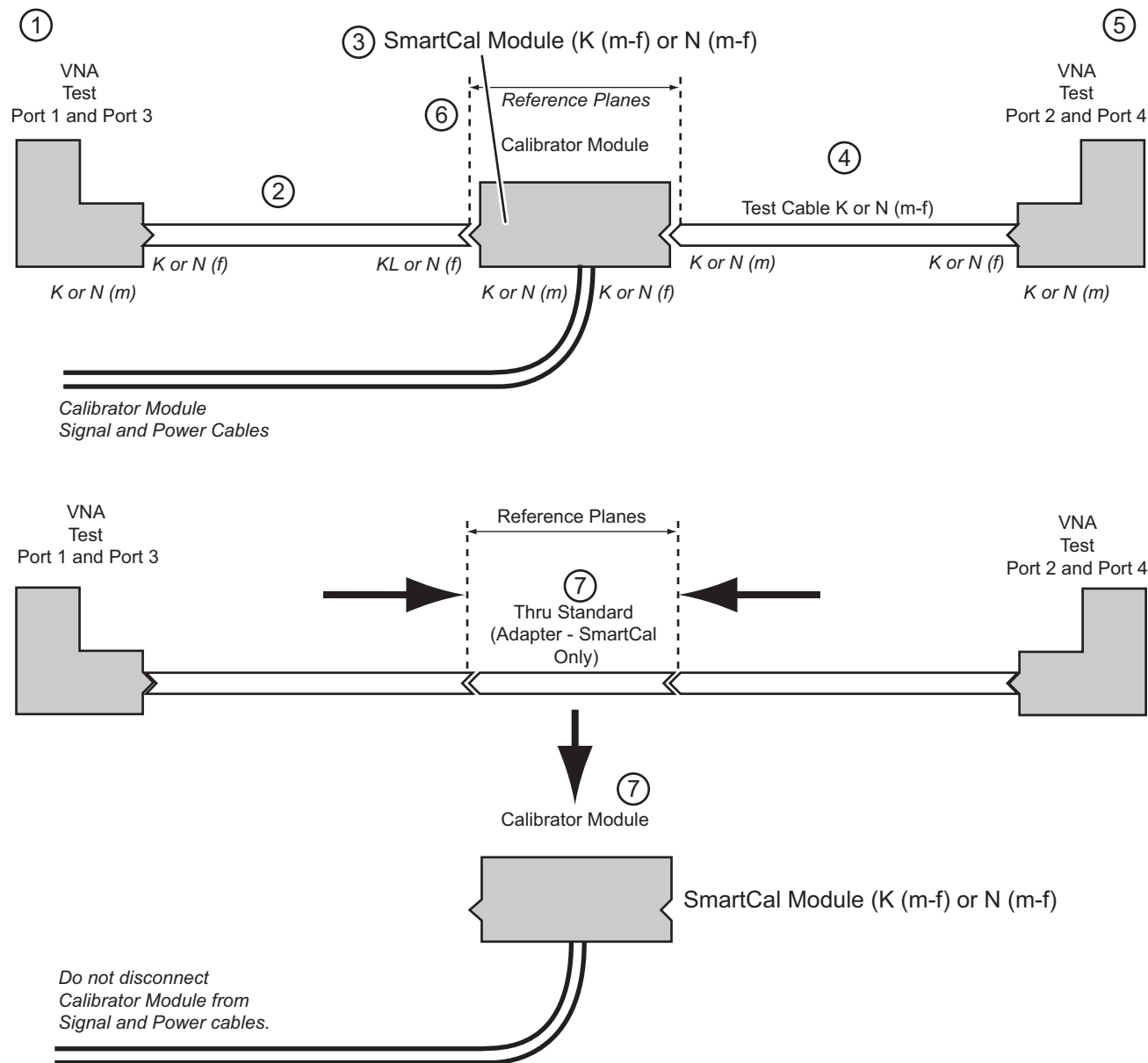
3. USB Power/Control cable

4. VNA USB Port

5. K or N (m-f) Test Cable connected to VNA Test Ports

**Figure 2-23.** Calibrator Cable Connections for True Through

Schematically, the connections shown in [Figure 2-23](#) above are shown in [Figure 2-24](#).



#### Part 1 – Calibration True Thru Procedure

1. VNA Test Port – 1 K (m) or N (f) Connector
2. K or N (f-f) Test Cable
3. Calibrator Module
4. K or N (m-f) Test Cable
5. VNA Test Port 2 – K or N (m) Connector
6. Resultant reference planes during first Calibration procedure.

#### Part 2 – Calibration True Thru Procedure

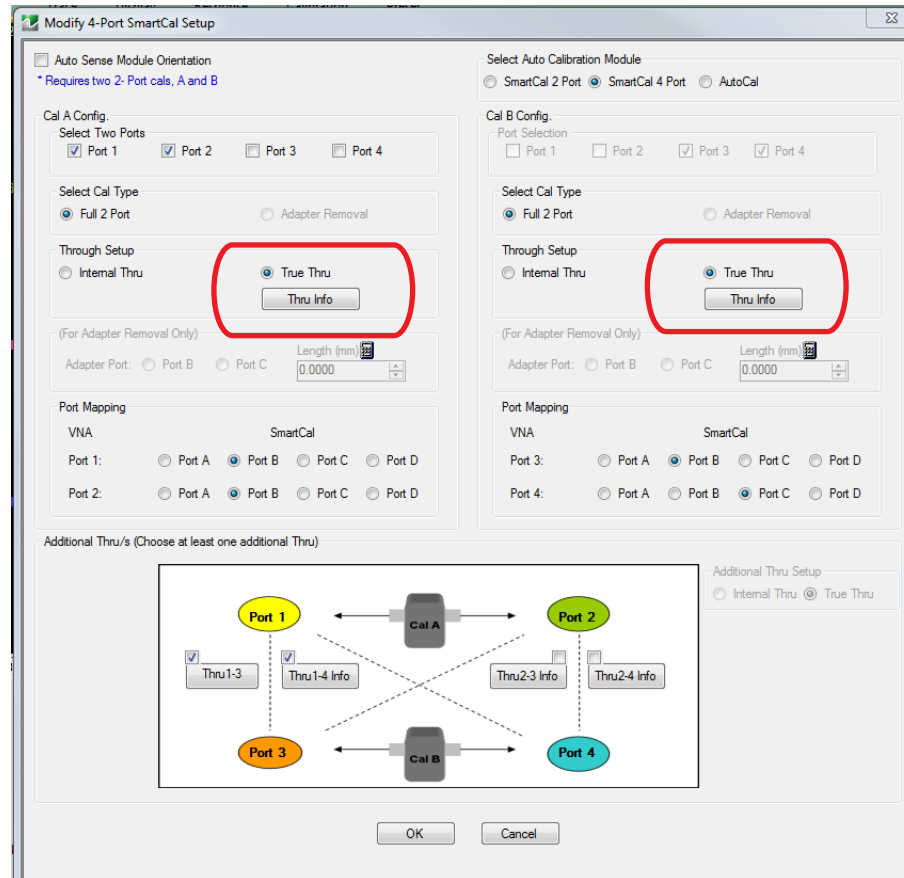
7. After initial calibrations, user is directed to remove Calibration module and connect the True Thru standard (adapter) between the test cables.
8. Follow the remaining instructions until calibration is complete.

**Figure 2-24.** Calibration Module True-Through Connections

6. Navigate to the AUTOCAL SETUP menu:

- MAIN | Calibration | CALIBRATION | Calibrate | CALIBRATE | AutoCal | AUTOCAL PORTS | 2-Port Cal | SMARTCAL SETUP

7. On the AUTOCAL SETUP menu, if the Cal Type, Thru Type, and Module Orientation display buttons do not show the correct values, select the Modify Cal Setup button.



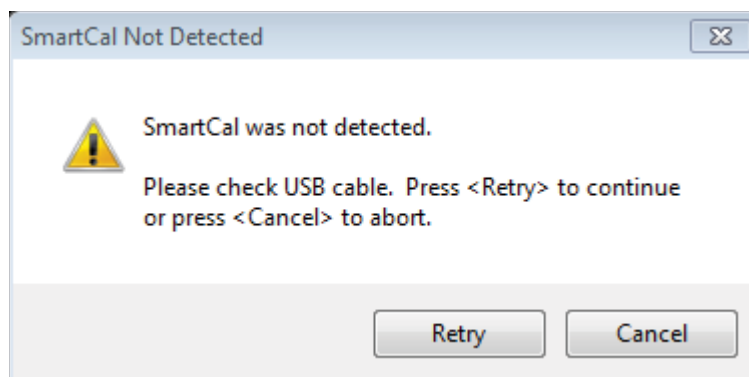
**Figure 2-25.** True Thru Selected

- The MODIFY 2-PORT AUTOCAL SETUP dialog box appears.
- Change the settings as required.
- In the Cal Type Select area: Select the Full Two Port radio button.
- In the Thru Select area, select THRU INFO dialog box appears.
- Enter information about the through line. Enter 0 length and 0 dB/mm loss (and a reference frequency of 0, which forces it to use that loss at all frequencies) and 50 ohm impedance. Select OK to close the dialog box.
- Select the Auto Sense Module Orientation check box
- Click OK to close the dialog box.

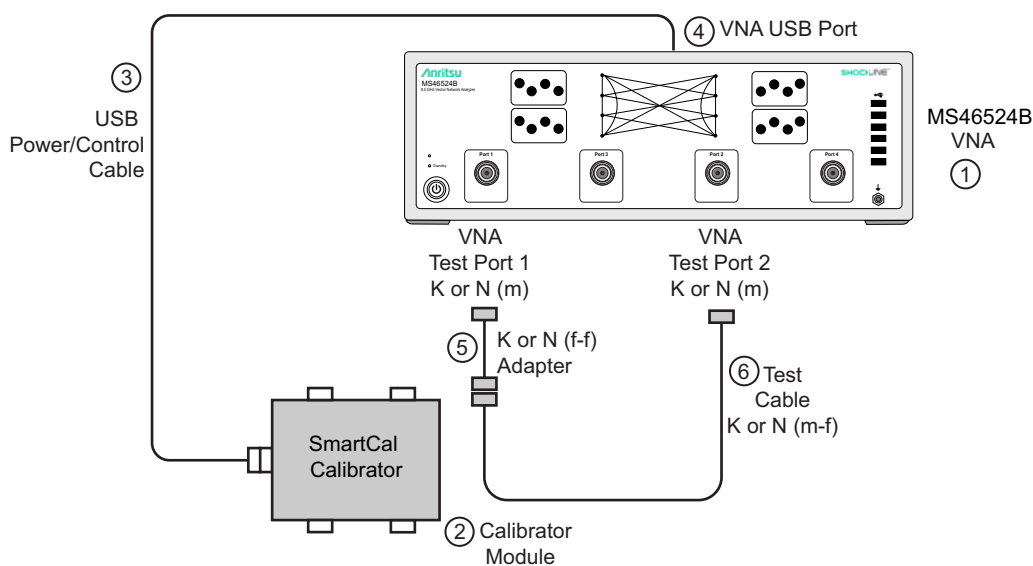
**Note** All existing system setups such as IF Bandwidth, Averaging, and Power Level will be applied during the calibration procedure.

- When ready, click the Begin Cal button.
- A status dialog box with a progress bar appears after an Calibration sequence has started.  
The status messages define how far the program has progressed and if any user actions are required.

10. At any time, the Calibration sequence can be canceled by clicking the dialog box Abort button.
11. A dialog box will appear when the true through is to be connected.
12. Connect the **Test Port 1 test cable** to the **Test Port 2 test cable**.



**Figure 2-26.** If the Calibration module is connected incorrectly, the AUTOCAL MODULE NOT DETECTED warning message appears. Correct connections as required and click the Retry button.



- |  |  |
|--|--|
| <ol style="list-style-type: none"> <li>1. ShockLine VNA with K or N Test Port Connectors</li> <li>2. SmartCal (K or N)</li> <li>3. AutoCal Module Power Supply connected to AC Power. AutoCal module and connect test cables. At all times during the calibration procedure, the AutoCal module must be connected to the VNA and to AC power.</li> </ol> | <ol style="list-style-type: none"> <li>4. VNA USB Port</li> <li>5. K or N (f-f) Adapter connected to VNA Test Port 1</li> <li>6. K or N (m-f) Test Cable connected to VNA Test Port 2</li> </ol> |
|--|--|

**Figure 2-27.** True-Through Connections - Module Removed

13. After connecting the through, select Continue.
14. When the auto calibration is complete, a status message appears with a statement about assurance passing or failing. On the CALIBRATION menu, the Cal Status field button shows ON.
15. Closing the dialog box returns to the CALIBRATION menu.

## 2-13 Calibration Module Characterization

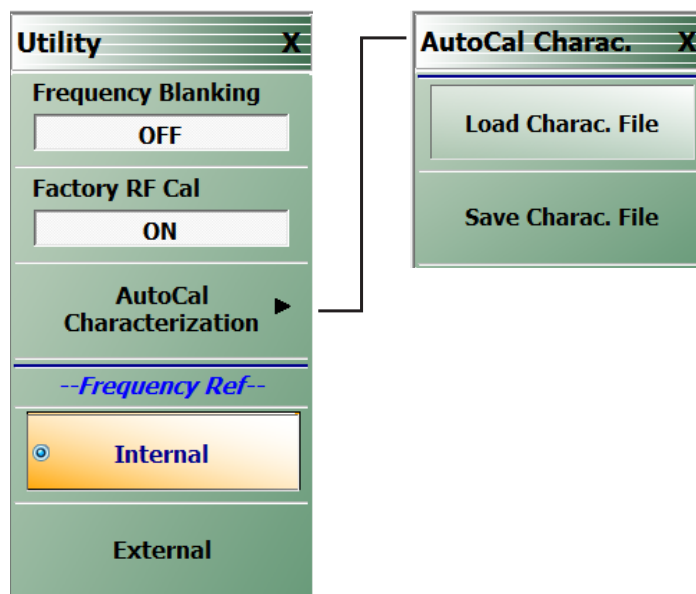
### Characterization

Typically, characterization is performed by Anritsu since the process can be very carefully controlled for maximum accuracy. In certain cases, the customer may wish to perform the characterization themselves but it is important to note that all specifications for the calibration are void and the customer takes responsibility for performing a characterization of adequate quality. With that caveat, the process for performing a characterization is as follows:

1. Setup the instrument for the frequency range, point count, power level, and IFBW desired. It is particularly important to use as many points as reasonable in order to reduce interpolation needs.
2. Perform as high a quality manual calibration as possible at the reference planes that will be connected to the Calibration module.
3. Connect the Calibration module to the reference planes, apply power, and connect the control cable to both the Calibration module and to the ShockLine VNA. Allow the AutoCal Calibration module to reach operating temperature so the blue **Operate LED** illuminates.
4. Select the AUTOCAL CHARAC. menu (shown below) to start characterization. The VNA will automatically switch the unit through its various states and characterize them. Alternatively, the connected test port order may be specified and may be necessary if there is substantial loss in the test setup (note that this may indicate an accuracy hazard).
  - MAIN | System | SYSTEM | Utility | UTILITY | AutoCal Characterization | AUTOCAL CHARAC.

**Note** This navigation path applies to both AutoCal and SmartCal calibration modules

5. Save the characterization file as appropriate. Note that the characterization file will be tied by serial number to the particular Calibration module that was characterized.



**Figure 2-28.** AUTOCAL CHARAC. (AUTOCAL CHARACTERIZATION) Menu

## 2-14 Adapter Removal – M-M or F-F Reference Plane

### Adapter Removal Overview

Adapter removal for Calibration modules primarily refers to the case of connector gender incompatibility when it is not desired to use test port converters such as when the user has a M-F Calibration module and M-M reference planes are required. A separate menu item is provided for Calibration adapter removal to speed up the process since fewer manual steps are needed. In this calibration sequence, one uses an adapter (that can mate the desired reference plane connectors) as part of the calibration.

Two possible scenarios are covered; both use a pair of calibration sequences to remove the effects of the adapter. In both of the cases below, it is assumed all connectors are from the same family. If not (e.g., one is using a special inter-series Calibration unit), then this Calibration-specific adapter removal technique may not be applied; see the standard adapter removal section.

This procedure performs an Calibration procedure when an adapter is required to accommodate either the Calibration unit or the DUT connector genders and a M-M reference plane is required.

### Required Equipment

- **VNA**  
MS4652xB VNA with K or N Test Port Connectors
- **Calibration Module**
  - AutoCal Precision Calibration Module, with K (f-m) connectors (AutoCal does not support N connectors). Includes the necessary Power Supply Module with cords to AutoCal Module and to AC power.
- **Test Cable**  
A test port cable with K or N (m-f) connectors
- **K or N (f-f) Adapter**  
Matched K or N (f-f) Adapter for SmartCal or Matched K (f-f) adapter for AutoCal 36583K

### Prerequisites

The following prerequisite procedures have already been accomplished:

- Calibration Characterization file previously loaded. (AutoCal only)
- MS4652xB powered up.
- Required settings for Frequency Start, Frequency Stop, Number of Points, and CW Mode configured.
- Optional settings as required for Segmented Sweep, IF Bandwidth, Averaging, and Port Power configured.

### Procedure

1. Make the necessary cable connections between the AutoCal Module, its Power Module, AC power, and the MS4652xB back panel.
  - When the blue **Operate LED** is illuminated, the module has warmed up and is ready for calibration operations.
2. Connect the **K or N (f-f) Adapter** to the **Calibration Module K or N (m) connector**.
  - Consider the Adapter and Calibration module as an “assembly” for the duration the Calibration procedure.

**Note** Once assembled, do not break the connection between the adapter and the Calibration module, do not disconnect the assembly from the **VNA USB Port**, and do not disconnect the assembly from AC power. If the connection between the adapter is broken before the Calibration procedure is completed, the entire calibration is invalidated and must be repeated.

3. Connect the remaining **Calibrator K or N (f)** connector to the MS4652xB **Test Port 1 K or N (m)** connector.
4. Connect the **Test Cable K or N (f)** connector to the MS4652xB **Test Port 2 K or N (m)** connector.
5. Connect the **Test Cable K or N (m)** connector to the **Calibration Module K or N (f)** connector.

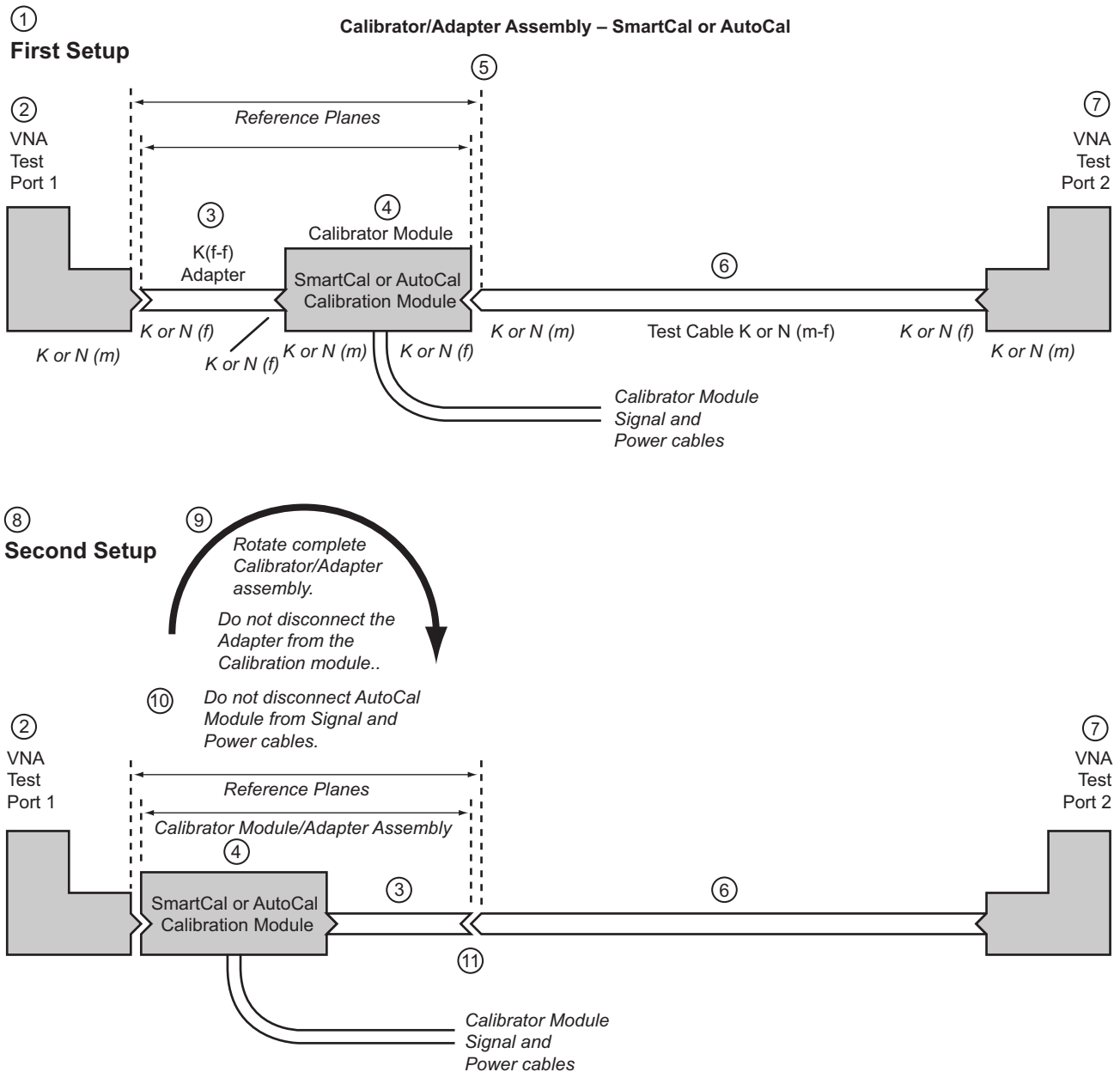


Figure 2-29. Calibrator, Adapter Removal, Internal Thru (1 of 2)

**Part 1 – Calibration Adapter Removal Procedure**

1. First setup for the Adapter Removal procedure.
2. VNA Test Port 1
3. K or N (f-f) Adapter
4. Calibration Module– For the duration of the calibration, the K or N (f-f) Adapter and the Calibration Module must be connected as an assembly. Do not disassemble or disconnect from its Power and Signal cables.
5. Resultant calibration reference planes.
6. K or N (m-f) Test Cable
7. VNA Test Port 2

**Part 2 – Calibration Module Adapter Removal Procedure**

8. Second setup for the Adapter Removal procedure.
9. After the first calibration, rotate the complete assembly so that the calibrator K or N (f) connector is connected to VNA Test Port 1. Do not disconnect the Adapter from the Calibration module.
10. Do not disconnect the Calibration Module from its Power or Signal cables.
11. Connect the K or N (f-f) adapter to the Test Cable K or N (m-f). The reference planes remain in place. The user is guided through the remaining steps of the procedure.

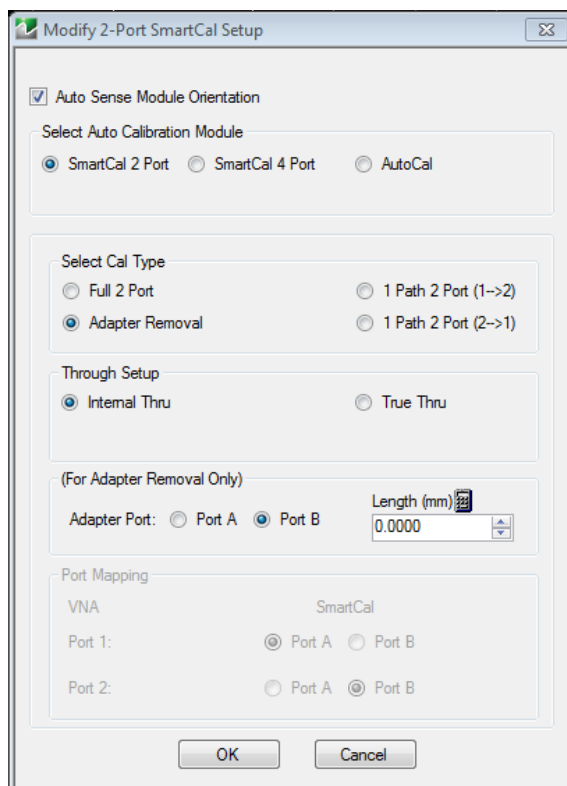
**Figure 2-29.** Calibrator, Adapter Removal, Internal Thru (2 of 2)

6. Navigate to the AUTOCAL SETUP menu.

- MAIN | Calibration | CALIBRATION | Calibrate | CALIBRATE | AutoCal | AUTOCAL PORTS | 2-Port Cal | AUTOCAL SETUP

7. If the Cal Type, Thru Type, and Module Orientation display buttons do not show the correct values, select the Modify Cal Setup button.

- The Modify Calibration Setup dialog box appears.

**Figure 2-30.** Adapter Removal Selected



8. Make the following changes to the Modify Calibration Setup dialog box settings:
  - a. Select the Auto Sense Module Orientation check box which allows the Calibration module determine the AutoCal Module left/right cable identification or SmartCal Module Port A/B cable identification.
  - b. In the Select Cal Type area, select the Adapter Removal radio button. The For Adapter Removal Only area becomes available.
  - c. In the Through Setup area, select the Internal Thru radio button and Adapter Removal.
  - d. In the For Adapter Removal Only area, enter the estimate of electrical length (in mm) and select which Calibration port the adapter is attached to.
  - e. Select OK to close the dialog box. The AUTOCAL SETUP menu reappears with new values for Cal Type, Thru Type, and Module Orientation.

<b>Note</b>	All existing system setups such as IF Bandwidth, Averaging, and Power Level will be applied during the calibration procedure.
-------------	---

9. When ready, click the Begin Cal button.
10. If the Calibration module is connected incorrectly, the Calibration Module Not Detected warning message appears. Correct connections as required and click Retry.
11. A status dialog box with a progress bar appears after an Calibration sequence has started. The status messages define how far the program has progressed and if any user actions are required.
12. At any time, the calibration sequence can be canceled by clicking the dialog box Abort button.
  - When the first calibration process is complete, the user is prompted to reverse the Adapter/Calibration assembly.

<b>Note</b>	Once assembled, do not break the connection between the adapter and the Calibration module. If the connection between the adapter is broken before the Calibration procedure is completed, the entire calibration is invalidated and must be repeated.
-------------	--

13. The instrument will prompt the user to reverse the module-adapter assembly.
14. As shown above in [Figure 2-29, “Calibrator, Adapter Removal, Internal Thru”](#) on page 2-37 above, disconnect the **Adapter** from **Test Port 1** and the **Calibration Module** from the **Test Cable** on Test Port 2.
15. Reverse the **Adapter/Calibration Module assembly** so that the Adapter end is pointing towards Test Port 2.
16. On the Calibration module, connect the free **K or N (f) connector** to Test Port 1 K (m).
17. On the Adapter, connect the free **Adapter K or N (f) connector** to the Test Cable connected to Test Port 2.
18. When the calibration is complete, a status message appears with a statement about assurance passing or failing. Closing the dialog will return to the regular menu system. On the CALIBRATION menu, the Cal Status field button shows ON.



# Chapter 3 — SOLT/SOLR Calibration

## 3-1 SOLT/SOLR Introduction

This chapter describes calibration procedures using the SOLT/SOLR calibration algorithms. One of the more common calibration algorithms is based on Short-Open-Load-Thru. This is a defined-standards calibration meaning the behavior of all of the components is specified in advance via data or models.

Since the behaviors of all standards are known, by measuring them with the VNA we can define all of the error terms. The load behavior largely sets the directivity terms, the short and open together largely determine source match and reflection tracking and the thru largely determines transmission tracking and load match.

## 3-2 Definitions

### Shorts

Shorts can be defined by a model consisting of a transmission line length and a frequency dependent inductance.

### Opens

Opens can be defined by a model consisting of a transmission line length and a frequency dependent capacitance.

### Loads

Loads can be defined by a model consisting of a transmission line length, a shunt capacitance, a resistance and a series inductance.

Note that a sliding load can be used in lieu of a fixed load. The sliding load is based on a sliding termination embedded in an airline and the transmission line properties of that airline are used to deduce a more nearly perfect synthetic load. Because of the transmission line dependence, a fixed load is also needed at low frequencies below 2 GHz.

### Thru

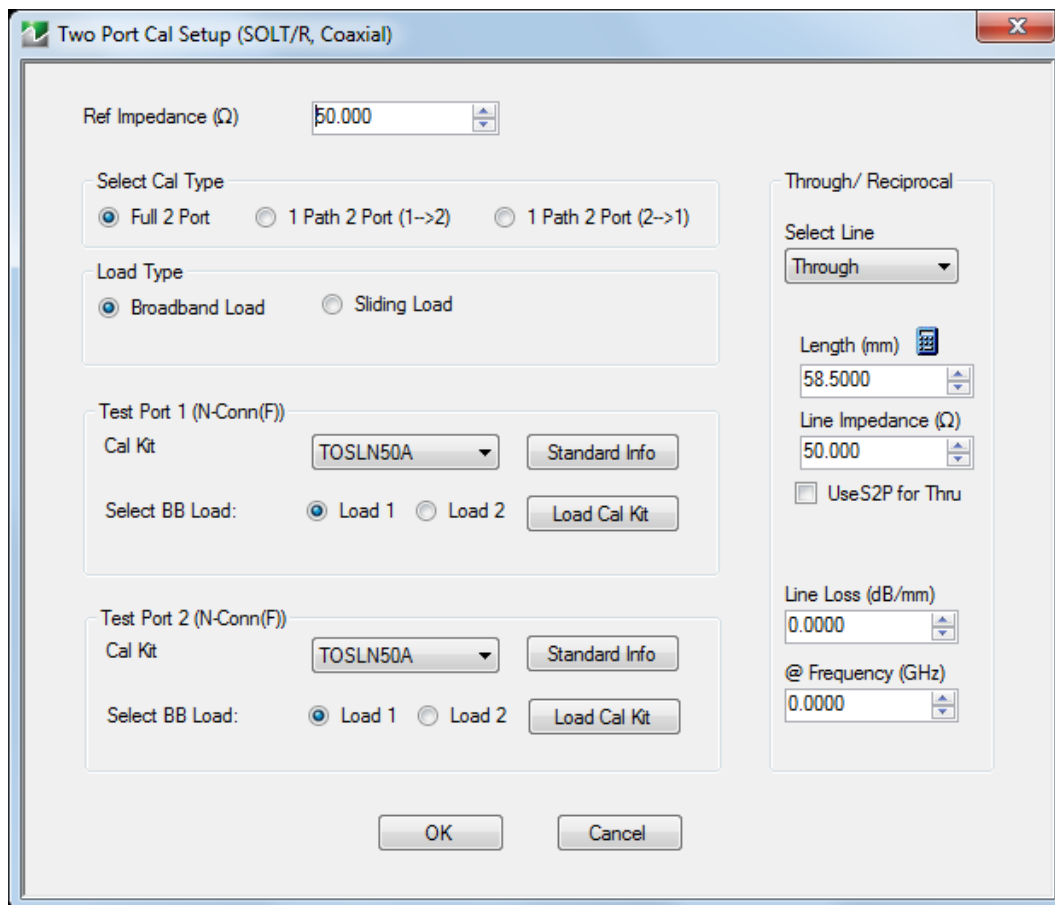
Modeled as a transmission line length with some frequency dependent loss. A root-f frequency dependence of that loss is assumed.

### Reciprocal

The thru can sometimes be replaced by a unknown but reciprocal network (like an adapter or a fixture) when an actual thru connection is not practical. The accuracy will be somewhat less than if an actual thru could have been used but will be better than assuming a poor thru is a good one.

### 3-3 2-Port Cal Setup

The coaxial setup dialog for SOLT (and SOLR), full 2-Port calibration is shown in below.



**Figure 3-1.** TWO PORT CAL SETUP (SOLT/R, COAXIAL) Dialog Box

The setup dialog above is for coaxial and non-dispersive line types. In the dialog, the connector types for both ports are selected as well as the through details and the type of load to be used. For one port calibrations, only one of the port definitions (unless reflection-only calibrations are being performed for both ports 1 and 2) will be present. For a 1 path-2 port cal, one of the Test Port definition sections will not be shown.

The setup dialog above is for coaxial and non-dispersive line types. For waveguide and microstrip, a few things change:

- Fewer cal kits are factory-defined and more are user-defined
- The media must be part of the definition (cutoff frequency and dielectric constant for waveguide; line width, substrate height, and substrate dielectric constant for microstrip)
- SOLT is not recommended for waveguide due to the difficulty in modeling and open standards

## MS46524B Two 2-Port

The MS46524B can perform two 2-port SOLT/SOLR cals simultaneously. The menu enables two separate cals to make a 4 port cal or a 2 port cal using different combinations of ports. [Figure 3-2](#).

Two Port Cal Setup (SOLT/R, Coaxial)

Ref Impedance ( $\Omega$ ) 50.000

**Cal A Config.**

Select Two Ports for Cal A

Port 1  Port 2  Port 3  Port 4

Select Cal Type

Full 2 Port  1 Path 2 Port (1-->2)  1 Path 2 Port (2-->1)

Load Type

Broadband Load  Sliding Load

Through/Reciprocal Setup

Select Line Through Length (mm) 58.5000 Line Impedance ( $\Omega$ ) 50.000

Line Loss (dB/mm) 0.0000 @ Frequency (GHz) 0.0000

\* Reciprocal not allowed between 1-2 and 3-4.

**Cal B Config.**

Cal B Ports

Port 1  Port 2  Port 3  Port 4

Select Cal Type

Full 2 Port  1 Path 2 Port (3-->4)  1 Path 2 Port (4-->3)

Load Type

Broadband Load  Sliding Load

Through/Reciprocal Setup

Select Line Through Length (mm) 58.5000 Line Impedance ( $\Omega$ ) 50.000

Line Loss (dB/mm) 0.0000 @ Frequency (GHz) 0.0000

\* Reciprocal not allowed between 1-2 and 3-4.

**Test Ports**

Test Port 1 (N-Conn(F))

Cal Kit TOSLN50A Standard Info

Select BB Load:  Load 1  Load 2 Load Cal Kit

Test Port 2 (N-Conn(F))

Cal Kit TOSLN50A Standard Info

Select BB Load:  Load 1  Load 2 Load Cal Kit

Test Port 3 (N-Conn(F))

Cal Kit TOSLN50A Standard Info

Select BB Load:  Load 1  Load 2 Load Cal Kit

Test Port 4 (N-Conn(F))

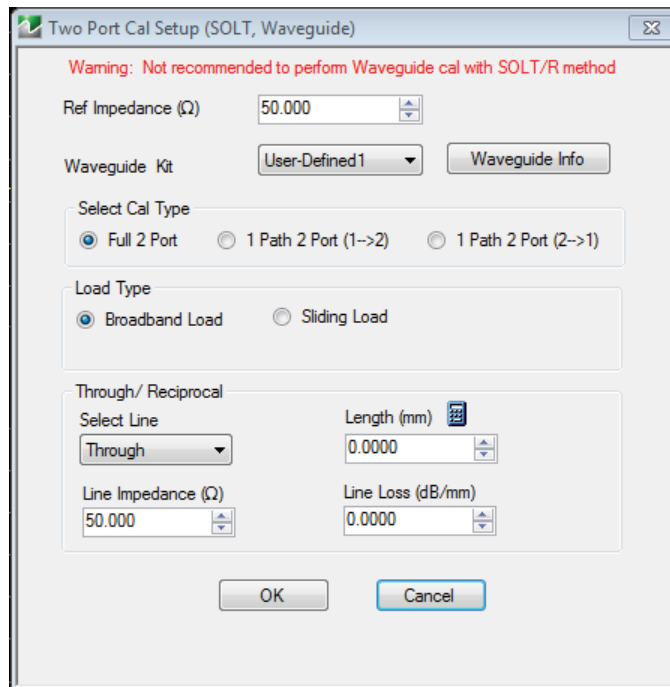
Cal Kit TOSLN50A Standard Info

Select BB Load:  Load 1  Load 2 Load Cal Kit

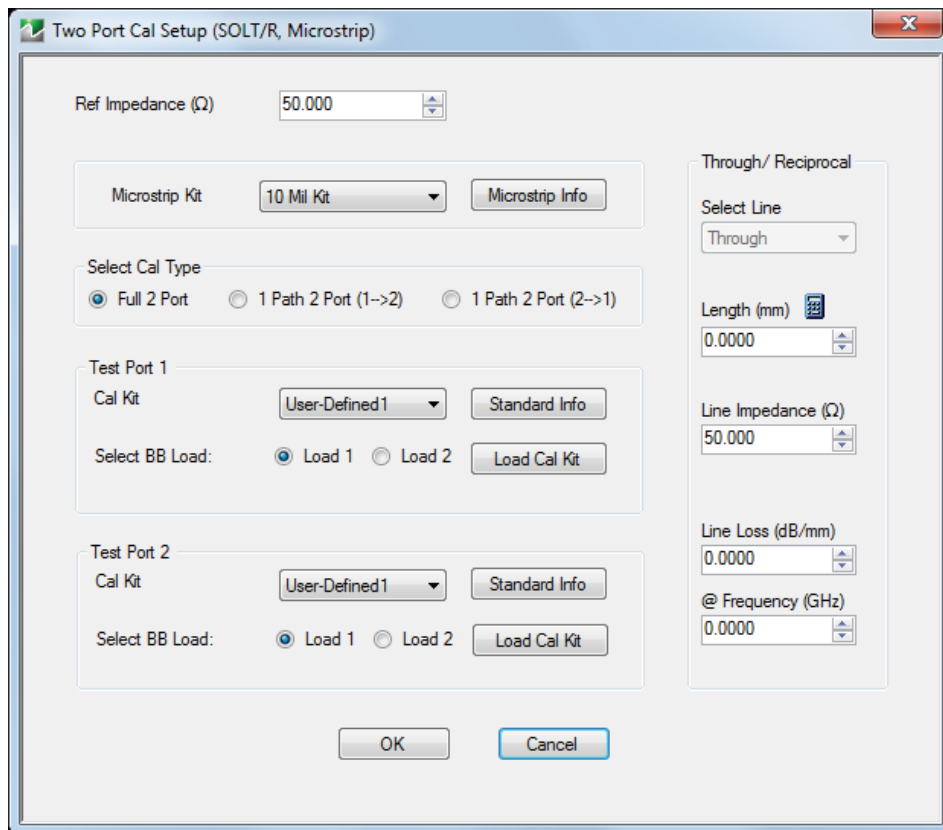
OK Cancel

**Figure 3-2.** MS46524B Two 2-Port Cal Setup Menu

A waveguide SOLT setup is shown in [Figure 3-3](#) and a setup for microstrip is shown in [Figure 3-4](#).

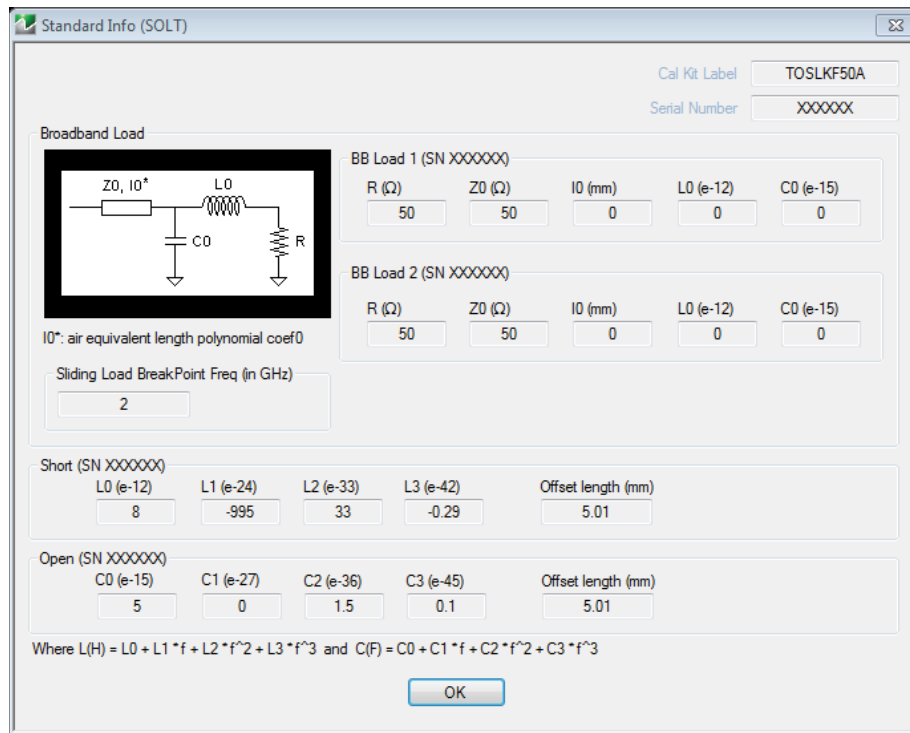


**Figure 3-3.** TWO PORT CAL SETUP (SOLT/R, WAVEGUIDE) Dialog Box



**Figure 3-4.** TWO PORT CAL SETUP (SOLT/R, MICROSTRIP) Dialog Box

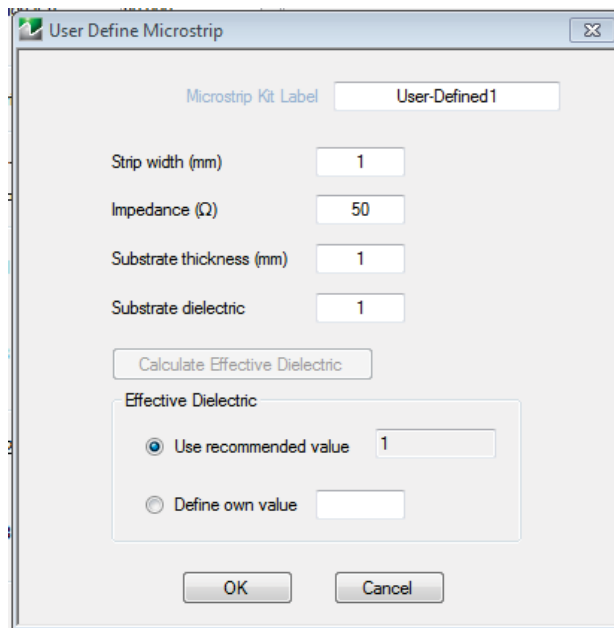
The standards information dialog for SOLT / SOLR is shown in [Figure 3-5](#).



**Figure 3-5.** STANDARD INFO (SOLT/R)

For cal kits loaded from Anritsu cal kit files, the model terms are not editable. When using user-defined cal kits, the model terms can be edited.

The standards information for microstrip does not change but the microstrip media information must be either user-defined (Figure 3-6) or selected from an Anritsu microstrip cal kit (Figure 3-7, typically used with Anritsu Universal Test Fixtures).

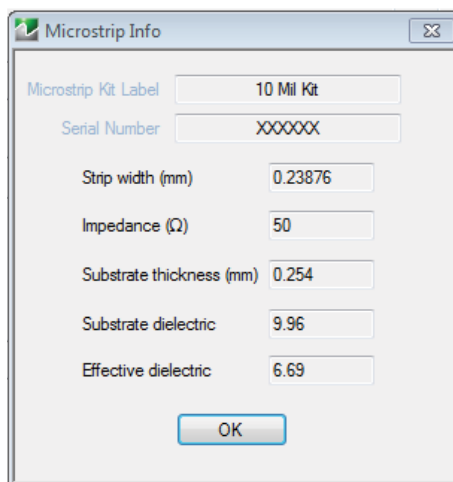


The 'User Define Microstrip' dialog box contains the following fields and controls:

- Microstrip Kit Label: User-Defined1
- Strip width (mm): 1
- Impedance ( $\Omega$ ): 50
- Substrate thickness (mm): 1
- Substrate dielectric: 1
- Calculate Effective Dielectric button
- Effective Dielectric section:
  - Use recommended value: 1
  - Define own value: [empty]
- OK and Cancel buttons

Figure 3-6. USER-DEFINED MICROSTRIP Data Input Dialog Box

Effective dielectric constants can be entered, or the recommended value can be selected.



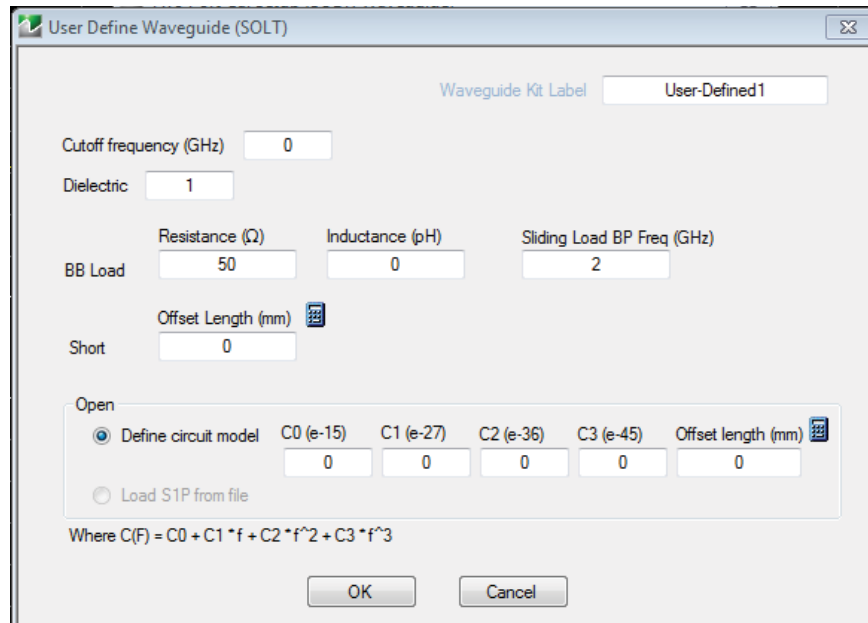
The 'Microstrip Info' dialog box displays the following information:

- Microstrip Kit Label: 10 Mil Kit
- Serial Number: XXXXXX
- Strip width (mm): 0.23876
- Impedance ( $\Omega$ ): 50
- Substrate thickness (mm): 0.254
- Substrate dielectric: 9.96
- Effective dielectric: 6.69
- OK button

Figure 3-7. MICROSTRIP INFO 10 Mil Kit Dialog Box



For waveguide, the model parameters and the media parameters are combined in one dialog ([Figure 3-8](#)).



**Figure 3-8.** USER-DEFINED WAVEGUIDE (SOLT/R) Information Dialog Box

**Note**

Reciprocal measurements (SOLR vs. SOLT) are covered in more detail in [Chapter 15, “Reciprocal Measurements”](#).

## 3-4 SOLT/SOLR Calibration

The following example presumes an MS4652xB Series VNA with K or N connectors. A different connector can be selected in step 4 if a different model/configuration is being used. It is assumed that a M-F cable is connected to port 2 so that a M (port 1) and F (port 2) reference plane pair is available. In this example, a full 2 port SOLT calibration will be performed although a number of other options are discussed along the way. The implications of these options are discussed in the calibration overview section.

1. Setup the desired frequency range (Frequency menu), power (Power menu) and IFBW/averaging (Averaging menu). As a default, the IFBW will be 1 kHz and the averaging will be off which is adequate for many applications. The default power level will vary depending on instrument model and options but will often be adequate for all passive and many active device measurements.
2. Navigate to the TWO PORT CAL menu.
  - MAIN | Calibration | CALIBRATION | Calibrate | CALIBRATE | Manual Cal | MANUAL CAL | 2-Port Cal | TWO PORT CAL

**Note** If a previous calibration exists, the Thru Update button will be active.

3. Select Modify Cal Setup. The CAL SETUP menu appears. On this level, select a cal method of SOLT/SOLR and a line type of Coaxial.
4. Select Edit Cal Params; the TWO PORT CAL SETUP (SOLT/R, COAXIAL) dialog box appears which describes the calibration components:
  - a. Reference impedance defaults to 50 ohms. This value is used for referencing the standards reflection coefficients and for reference plane shift and Smith chart calculations. The latter two items can be handled later using a per-trace definition of reference impedance. The standards definition process is not affected by that later per-trace reference impedance change.
  - b. In the Load Type area, select broadband load. A sliding load can be used for better performance if one is available in the calibration kit. If low frequencies are included in the frequency range (< 2 GHz for K or GPC3.5), then a broadband load will be used in addition to the sliding load.
  - c. In the Through/Reciprocal area, a zero-length (or mating) thru will be used. Set the Select Line field to Through, 0 mm for the length and 0 dB/mm loss. Zero can also be entered for the reference frequency. When 0 is entered for this value, no loss scaling is employed and the entered loss value is used for all frequencies. If a reciprocal network was being used instead of a through, use Reciprocal for the Select Line field and the length entered would serve as an estimate for root choice purposes.
  - d. For **Port 1**, select a DUT connector of N (f). Note the dialog will then indicate that port connector is N(m).
  - e. For **Port 2**, select a DUT connector of N (m). The dialog will indicate a port connector of N (f).
  - f. For both ports, select a BB load of Load 1. This selection is for certain firmware/cal kit versions where modeled loads are available and the distinction between loads is important.
  - g. Select OK to close the dialog. Select Back at the bottom of the menu to return to the previous level and the TWO PORT CAL menu where two Reflective Devices buttons appear with six reflection standards on the two submenus.

**Note** The menu calibration steps can be performed in any order. For these example, a top to bottom menu approach is assumed

5. Select Port 1 Reflective Devices and the REFL. DEVICES PORT 1 menu. On the menu, measure the three reflection standards of Open, Short, and Load. Connect each standard in turn, and THEN, click the corresponding button. When all are done, click the Back button to return to the TWO PORT CAL menu.

6. Then select **Port 2 Reflective Devices** and the **REFL. DEVICES PORT 2** menu where next three reflection standards are listed. When all six are done (and six check marks appear), click **Done** to return to the previous level and the **TWO PORT CAL** menu.
7. After measuring all six reflection standards, connect the cable to **Port 1** to complete the zero length through. Now click on the **Thru/Recip** button where a check mark should appear after the sweep pair. Note that the displayed graphs may change during this step as the instrument must measure all four S-parameters of the thru line.
8. An optional isolation step using the **Isolation (Optional)** button and the linked **ISOLATION** menu is available but is generally not recommended. If desired, terminate **Port 1** and the end of the cable attached to **Port 2** before clicking on the **Isolation (Optional)** button if needed.
9. Click on **Done**. The calibration is now completed and turned on where the **Cal Status** button on the **CALIBRATION** menu is set to **ON**.



# Chapter 4 — Offset Short (SSLT) Calibration

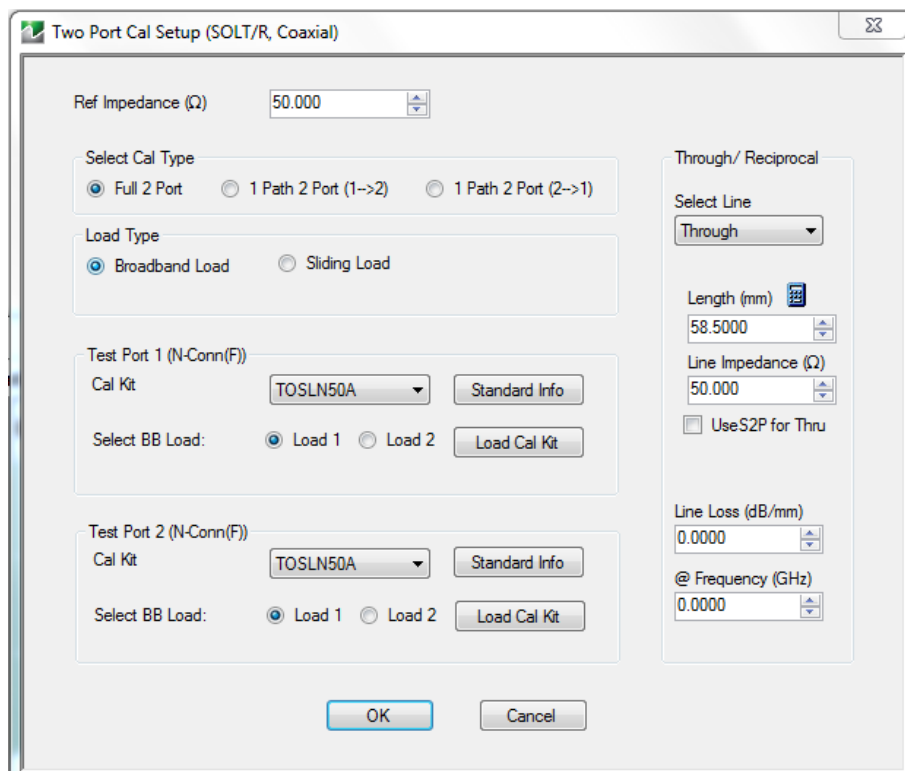
## 4-1 SSLT Introduction

This chapter describes calibration methods and procedures using the SSLT calibration algorithm.

The SSLT calibration differs from an SOLT calibration by the differing offset lengths between two shorts which are used to help define reflection behavior instead of an open and short. Because of this, the frequency range is limited since, at DC and at higher frequencies, these reflect standards will look the same. This method is most commonly used for waveguide problems where creating a stable, high reflection open standard is difficult, but there are certain coax and board-level or wafer-level situations where it is useful. The modeling constructs are about the same as for a SOLT calibration. From an error term perspective, the only difference is that the two shorts together now largely determine source match and reflection tracking behavior.

The electrical length difference between the shorts should be between 20 and 160 degrees over the frequency range of interest.

The top calibration kit definition dialog box for SSLT calibration is identical to the SOLT dialog (Figure 3-1, “TWO PORT CAL SETUP (SOLT/R, COAXIAL) Dialog Box” on page 3-2). Figure 3-1, “TWO PORT CAL SETUP (SOLT/R, COAXIAL) Dialog Box” on page 3-2. The standards information dialog box is different and is shown below.



Typical parameters for Offset Short Calibrations

**Figure 4-1.** STANDARD INFO (OFFSET SHORT) Information Dialog Box

## 4-2 SSLT Calibration Example

The following example presumes a MS4652xB ShockLine is being used with waveguide adapters (since SSLT is commonly used with waveguide). In this example, a full 2-Port SSLT calibration is performed although a number of other options are available. The implications of these options are discussed in the calibration overview section.

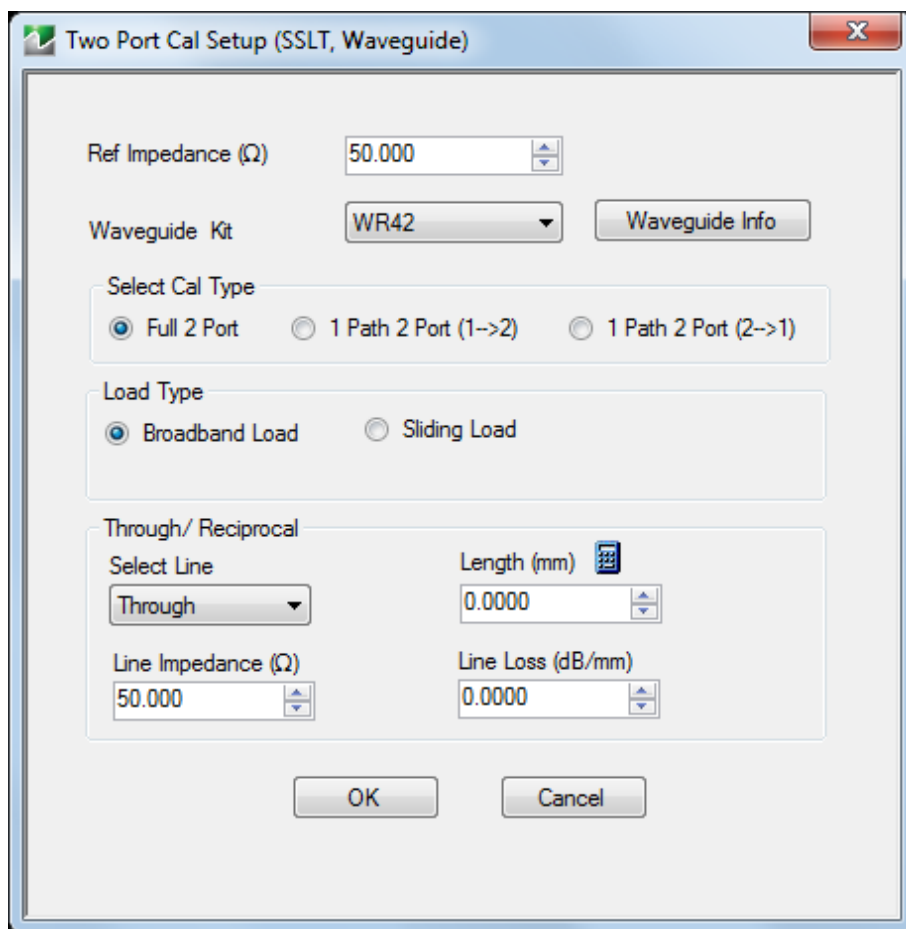
Set the desired frequency range (Frequency menu) and IFBW/Averaging (Averaging menu). The default power level varies depending on the instrument model and options, but will often be adequate for all passive and many active device measurements. The default IFBW is 1 kHz with averaging off, which is adequate for many applications.

1. Navigate to the TWO PORT CAL menu.

- MAIN | Calibration | CALIBRATION | Calibrate | CALIBRATE | Manual Cal | MANUAL CAL | 2-Port Cal | TWO PORT CAL

**Note** If a previous calibration exists, the Thru Update button will be active. See [“Through \(Thru\) Update” on page 9-1](#) for more information.

2. Select Modify Cal Setup, then on the CAL SETUP menu, select a Cal Method of SSLT and a Line Type of Waveguide.



**Figure 4-2.** TWO PORT CAL SETUP (SSLT, WAVEGUIDE) Dialog Box

3. Select Edit Cal Params which displays the TWO PORT CAL SETUP (SSLT, WAVEGUIDE) dialog box describing the calibration components (shown above).

- a. Reference impedance defaults to 50 ohms. Although this does not represent the waveguide impedance, it is commonly used for conventional Smith chart referencing. Reference impedance can be changed here for certain waveguide applications or it can be changed later on a per trace basis from the DISPLAY menu.
- b. Select **Broadband Load**. A sliding load can be used for better performance if one is available in the calibration kit. If low frequencies are included in the frequency range (< 2 GHz), then a broadband load will be used in addition to the sliding load.
- c. A zero-length (or mating) thru will be used so enter **Through** for the line, 0 mm for the length and 0 dB/mm loss. Zero can be entered for the reference frequency when no loss scaling is employed and the entered loss value is used for all frequencies. If a reciprocal network was being used instead of a through, the line selection would be **Reciprocal** and the length entered would serve as an estimate for root choice purposes.
- d. For a waveguide kit, select **WR42** (for this example). A user-defined kit can be selected from the pull-down menu, but the cutoff frequency, the dielectric, the short offset lengths, and the load impedance (relative to the reference impedance) will have to be specified.
  - Variations for other line types (waveguide or microstrip) are similar to those for SOLT. For waveguide, the media and standards information are combined as shown in [Figure 4-3](#). Defined, un-editable values would be present for Anritsu-defined cal kits. A simplified short model is used for waveguide, with only an offset length and no inductance terms since usually those terms are small.

The screenshot shows a dialog box titled "Waveguide Info (SSLT)" with the following fields and values:

Waveguide Kit Label	WR42	
Serial Number	XXXXXX	
Cutoff frequency (GHz)	14.08	
Dielectric	1	
Offset Length (mm)		
Offset short 1	2.35	
Offset short 2	7.05	
BB Load	Resistance ( $\Omega$ )	Inductance (pH)
	50	0
Sliding Load BP Freq (GHz)	2	
OK		

Typical parameters for an Offset Short Calibration

**Figure 4-3.** Waveguide Media and Standards Information

- e. Select **OK** to close the dialog, then select **BACK** at the bottom of the menu to return to the previous level and the **TWO PORT CAL** menu.

4. The Port 1 Reflective Devices and the Port 2 Reflective Devices buttons display the REFL. DEVICES PORT 1 and PORT 2 menus. The six reflection standards to be measured (Short 1, Short 2, Load on each menu) will be displayed here along with the read-only fields showing the port connector choices. Connect each standard in turn, and THEN, click the corresponding button. When all six are done (and six check marks appear), click Done to return to the previous level and the TWO PORT CAL menu.
5. After measuring all six reflection standards, connect the test cable to **Port 1** to complete the zero length through. Click on the Thru/Recip button to display the THRU/RECIP menu where a check mark should appear after the sweep pair. Note that the displayed graphs change during this step as the instrument must measure all four S-parameters of the through line.
6. An optional isolation step is available but is not recommended. If desired, terminate **Port 1** and the end of the cable attached to **Port 2** before clicking on the Isolation (Optional) button and displaying the ISOLATIONS menu.
7. When all steps are successfully completed, the Done button is available where select returns to the CALIBRATION menu where the Cal Status button is set to ON.
8. The calibration is now completed and turned on.

<b>Note</b>	Much like SOLT/SOLR, there is another version of SSLT using a reciprocal in place of a thru called SSLR. Reciprocal measurements (SOLR vs. SOLT) are covered in more detail in <a href="#">Chapter 15, "Reciprocal Measurements"</a> .
-------------	--



# Chapter 5 — Triple Offset Short (SSST) Calibration

## 5-1 SSST Introduction

This chapter describes calibration using the triple offset short (SSST) algorithm. The next step in this progression is to remove the load so that the entire reflection space is defined by three shorts of varying offset lengths. The individual short definitions are the same as for an SOLT calibration.

## 5-2 SSST and Reflectivity Error Terms

With an SSST calibration the three shorts together determine all of the reflectivities error terms (directivity, source match and reflection tracking). This calibration is more band-limited than the double offset short method. If short1 is defined as having the smallest offset length, and short3 to the longest offset length, then two variables can be defined:

---

$$A = L_{offset\_short2} - L_{offset\_short1}$$
$$B = L_{offset\_short3} - L_{offset\_short2}$$

---

### Equation 5-1.

The electrical length equivalents of A and B should generally be between 20 and 85 degrees over the frequency range of interest. This is not sufficient in itself since one will also require that A+B (which represents the difference between short1 and short3) also be constrained:

---

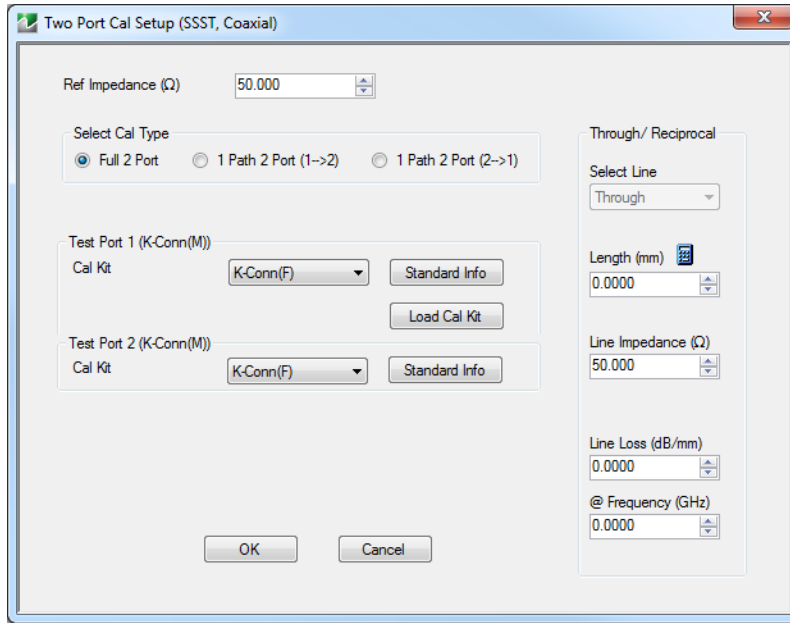
$$20 < \frac{720 \cdot f \cdot B}{v_{ph}} < 90$$
$$20 < \frac{720 \cdot f \cdot A}{v_{ph}} < 90$$
$$20 < \frac{720 \cdot f \cdot (A + B)}{v_{ph}} < 160$$

---

### Equation 5-2.

Since the only standards needed are shorts, this method is attractive for mm-Wave applications and for certain board-level and wafer-level calibrations where other types of standards are difficult to manufacture.

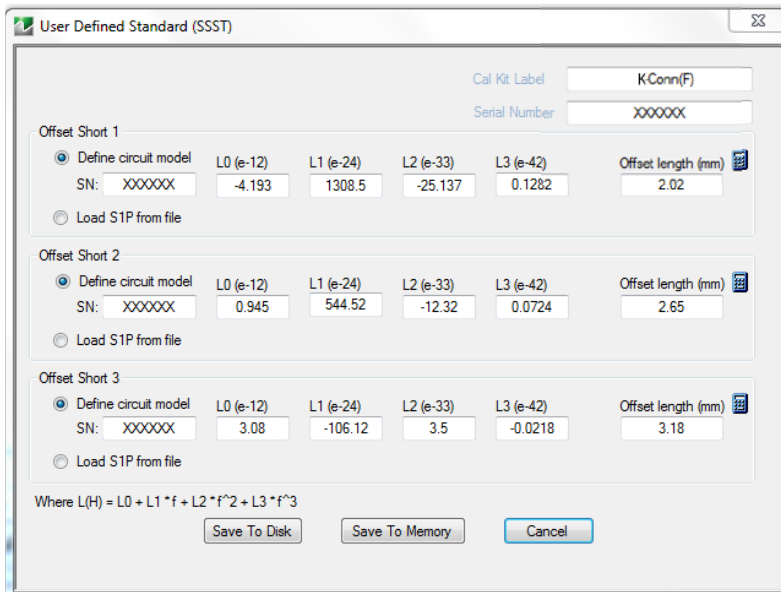
The setup and standards information dialogs for SSST are shown in Figure 5-1 and Figure 5-2 for a 2-Port calibration.



Typical parameters for Triple Offset Short calibration - SSST - Coaxial

**Figure 5-1.** TWO PORT CAL SETUP (SSST, COAXIAL)

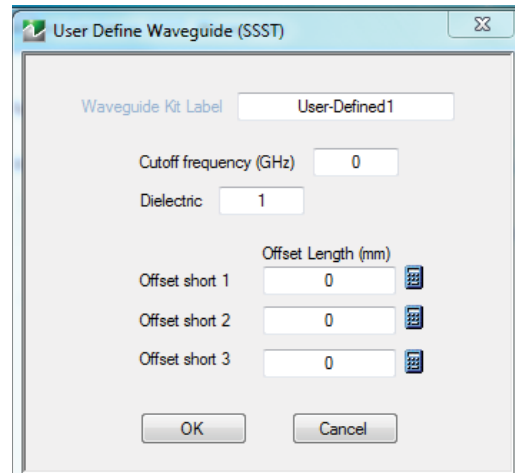
For one port calibrations, only one of the port definitions (unless reflection-only calibrations are being performed for both ports 1 and 2) will be present and the through line section will not be present. For a 1 path-2 port calibration, one of the port definition sections will not be present.



Typical parameters for SSST calibration - K (F) Connectors

**Figure 5-2.** STANDARD INFO (TRIPLE OFFSET SHORT) Information Dialog Box

Variations for other line types are similar to those for SOLT. For waveguide, the media and standards information are again combined into one dialog ([Figure 5-3](#)).



Typical parameters for SSST calibration - Waveguide - User-Defined 1 - Triple-Offset Short Calibrations

**Figure 5-3.** USER DEFINED WAVEGUIDE (SSST) Information Dialog Box

**Note**

Reciprocal measurements (SSSR) are covered in more detail in [Chapter 15, "Reciprocal Measurements"](#).

## 5-3 SSST Waveguide Calibration Example

The following example presumes an MS4652xB Series VNA with Option 82. The MS46522B-082 has tethered modules with a WR12 waveguide interface.

In this example, a full 2-Port SSST calibration will be performed although a number of other options are discussed along the way. These options are discussed in the Calibration Overview section.

1. Set the desired frequency range (FREQUENCY menu) and IFBW/Averaging (AVERAGING menu). The default power level varies depending on the instrument model and options, but will often be adequate for all passive and many active device measurements. The default IFBW is 1 kHz with averaging off, which is adequate for many applications.
2. Navigate to the TWO PORT CAL menu.
  - MAIN | Calibration | CALIBRATION | Calibrate | CALIBRATE | Manual Cal | MANUAL CAL | 2 -Port Cal | TWO PORT CAL

**Note** If a previous calibration exists, the Thru Update button will be active. See the Calibration Overview section for more information.

3. Select Modify Cal Setup, and on the CAL SETUP menu, select a Cal Method of SSST and a Line Type of Waveguide.
4. Select Edit Cal Params, the TWO PORT CAL SETUP (SSST, WAVEGUIDE) dialog box appears (shown below).

**Figure 5-4.** TWO PORT CAL SETUP (SSST, WAVEGUIDE) Dialog Box

5. In the TWO PORT CAL SETUP (SSST, WAVEGUIDE) dialog box, set the following calibration components:
  - a. Reference impedance defaults to 50 ohms. This establishes the reference impedance for reference plane changes and Smith chart plotting but can be changed later on a per-trace basis.
  - b. In the Select Cal Type area, select the Full 2 Port radio button.

- c. A zero-length (or mating) thru will be used so enter **Through** for the line, 0 mm for the length and 0 dB/mm loss. Zero can be entered for the reference frequency when no loss scaling is employed and the entered loss value is used for all frequencies. If a reciprocal network was being used instead of a through, the line selection would be **Reciprocal** and the length entered would serve as an estimate for root choice purposes.
  - d. Select **WR12** in the Waveguide kit selection. This should be default.
  - e. Click **OK** to close the dialog. Select **Back** at the bottom of the menu to return to the previous level and the **TWO PORT CAL** menu.
6. The **Port 1 Reflective Devices** and the **Port 2 Reflective Devices** buttons display the **REFL. DEVICES PORT 1** and **PORT 2** menus. The six reflection standards to be measured (**Short 1**, **Short 2**, **Short 3** on each menu) will be displayed here along with the read-only fields showing the port connector choices. Attach each standard in turn, and then click the corresponding button. When all six are done (and six check marks appear), click **Done** to return to the previous level and the **TWO PORT CAL** menu.

<b>Note</b>	Waveguide offset Short standards are required to have aligned apertures with the ShockLine tethered module to have valid calibration.
-------------	---

7. After measuring all six reflection standards, connect the both tethered modules together to complete the zero length through. Click on the **Thru/Recip** button to display the **THRU/RECIP** menu where a check mark should appear after the sweep pair. Note that the displayed graphs change during this step as the instrument must measure all four S-parameters of the through line.
8. When all steps are successfully completed, the **Done** button is available where select returns to the **CALIBRATION** menu where the **Cal Status** button is set to **ON**.
9. Click **Done**. The calibration is now completed and turned on.



# Chapter 6 — LRL/LRM Calibration

## 6-1 LRL/LRM Introduction

This chapter describes LRL/LRM calibration algorithms and procedures. The LRL/LRM family of calibrations relies more on the fundamental behavior of certain components (primarily transmission lines) than it does on characterized/modeled behaviors of components. It makes less use of redundancy, so fewer measurements are needed to complete a calibration, but it is also less tolerant of poor or non-repeatable measurements.

## 6-2 LRL/LRM Comparison

### LRL - Line-Reflect-Line

LRL (Line-Reflect-Line) uses two (or more) transmission lines and a reflect standard (for each port). The line lengths are important as it is required that the two lines look electrically distinct at all times (meaning it will not work at DC nor at a frequency where the difference in length is an integral number of half wavelengths). The reflect standard is assumed to be symmetric and without a high return loss. The lines are assumed perfect (no mismatch), and are usually airlines for coaxial calibrations, although other structures can be used. On-wafer transmission lines can be very good and this calibration approach will work well if the required probe movement can be managed.

### LRM - Line-Reflect-Match

LRM (Line-Reflect-Match) calibrations have one of the lines above replaced with a match (or load). The load is modeled/characterized (or assumed perfect). Since only one line is involved, this calibration can work down to DC and up to very high frequencies (practically limited by the match knowledge/characterization). Variations allow one of the match measurements to be traded for a pair of additional reflect measurements (a second reflect standard is needed). Because of the requirement that the reflect standards be distinct, the calibration may become band limited.

In the limiting case of a match that is assumed perfect, or at least assumed symmetric, this calibration reduces to the classical LRM. The added flexibility is in the ability to define asymmetric load models and to use multiple reflect standards as discussed above. The double reflect methodology allows one to feed into a load modeling utility where the load model can be further optimized.

Some parameters to keep in mind:

#### Line Lengths

In addition to the LRL frequency limits, the line length is used for some reference plane tasks. The fundamental reference plane of an LRL calibration is in the middle of the first line. If the reference plane is required at the ends of this line, the line length (and loss which can also be entered) is used to rotate the reference planes to the desired location. The line length delta is also used for some root choice tasks, although the accuracy required on this entry is less.

#### Line Length Delta

As mentioned above, the usable frequency range for LRL is set by the line length delta. Strictly speaking, the electrical length should be between 0 and 180 degrees for all frequencies of interest although some margin is usually desired to account for line parasitics, spurious mode launches and other problems. In general, the delta should be kept between 10 and 170 degrees or 20 and 160 degrees. Practically speaking, one can usually be more aggressive on the lower number and will want to be less aggressive on the upper number:

$$10 < \frac{360 \cdot f \cdot \Delta L}{v_{ph}} < 160$$

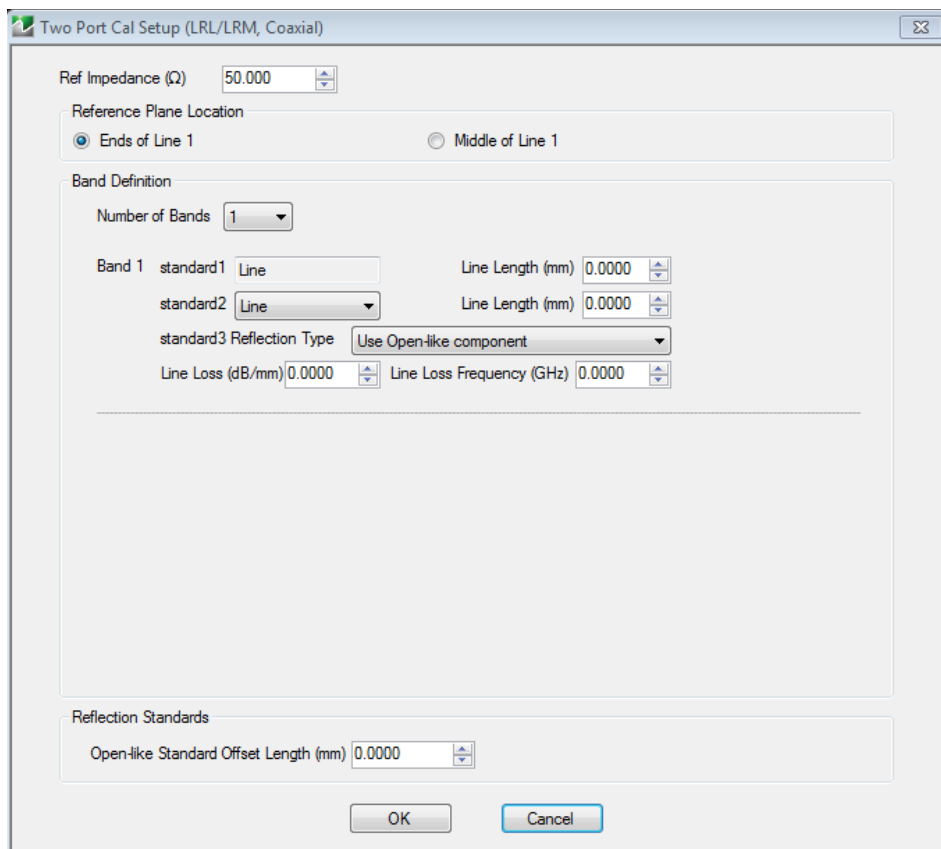
### Equation 6-1

Where  $\Delta L$  is in meters,  $v_{ph}$  is the phase velocity of the line ( $= 2.9978 \cdot 10^8 \text{ m/s} = c$  for air dielectric) and  $f$  can be any frequency in the range of interest, expressed in Hz.

If this range is too small for the application, multiple lines and multiple bands can be used. Each band uses a line pair covering some range of interest. LRL can be combined with LRM (LRM usually covering the low frequency end) within the calibration system. When two bands are used, a frequency break point must be specified to indicate when to switch from one calibration to the other. A suggestion can be calculated and this will be done based on the line lengths entered.

The setup dialog for LRL/LRM is quite flexible with decisions made based on what standards are selected. Several examples are shown in the figures below.

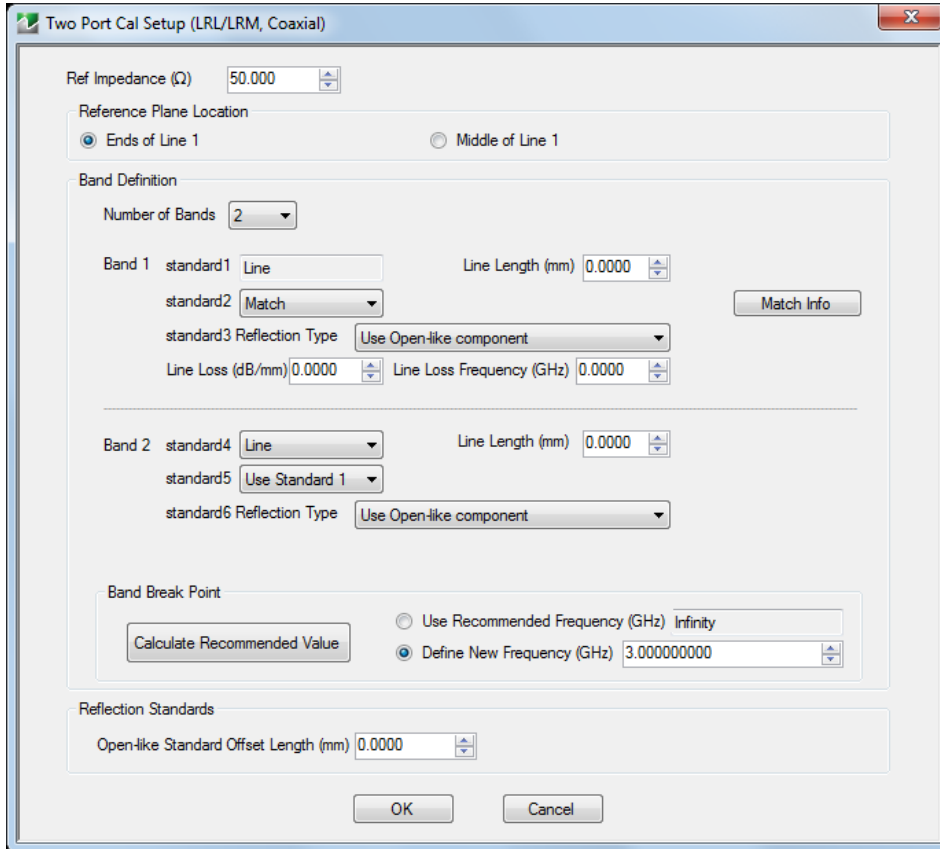
The Cal Merge (concatenation) utility can also be used with any other calibration types in order to cover a wider frequency range.



Typical parameters - One-Band LRL calibration

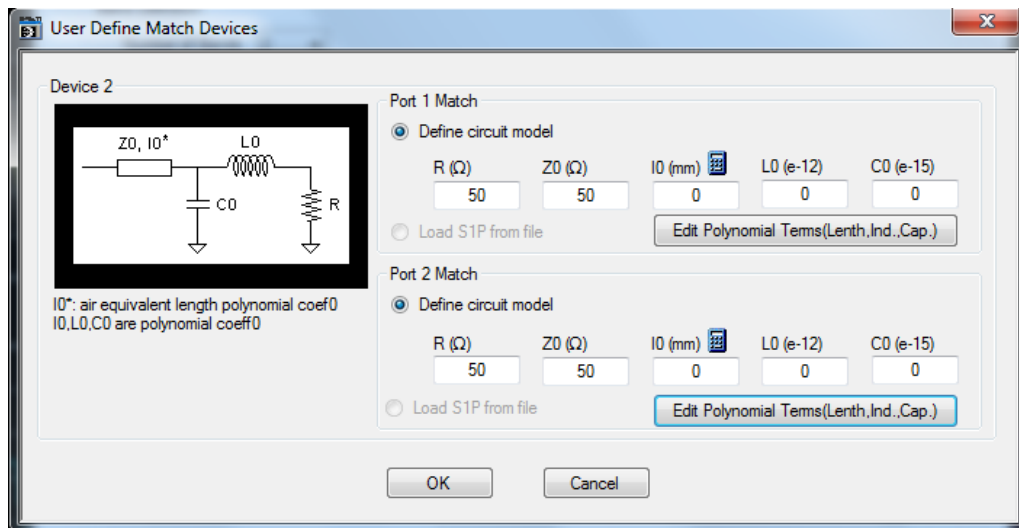
**Figure 6-1.** TWO PORT CAL SETUP (LRL/LRM, COAXIAL) Dialog Box





Typical parameters – Two-Band LRL calibration: Band 1 LRM - Band 2 LRL

**Figure 6-2.** TWO PORT CAL SETUP (LRL/ALRM, COAXIAL) Dialog Box



Typical parameters - Defining the Load for LRM (match info)

**Figure 6-3.** USER DEFINED MATCH DEVICES Dialog Box

## Reflection Offset Length and Reflection Type

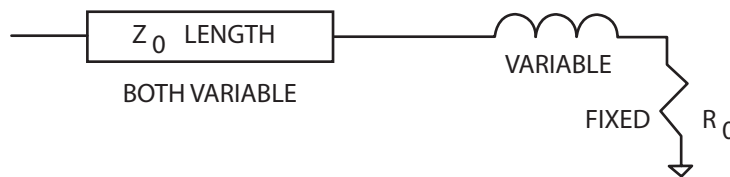
Some information is requested about the reflection although a full characterization is not needed. The information is used in some root-choice activities and it only needs to be known if the reflect behaves more like an open or a short (since typically opens and shorts are used as the reflect standard). The offset length is used to dynamically move the reference planes around so the algorithm will know what the reflect looks like at any given frequency.

In the double reflect LRM methodology it is important that the reflect standards be distinct. More specifically, they must be distinct when rotated to the reference plane at the center of line 1. Since large offset lengths will lead to many more degeneracies, this double reflect option will generally be used when offset lengths are smaller (such as in on-wafer or fixtured calibrations).

## Load Model/Characterization for LRM

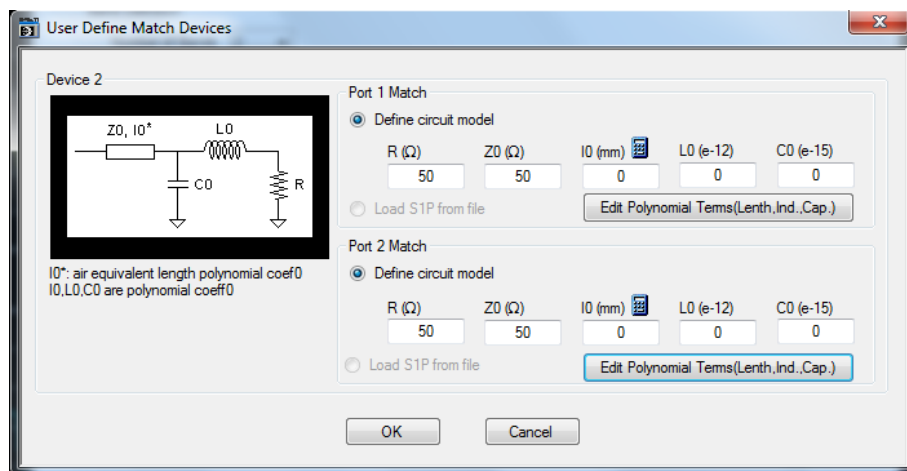
When a single reflect approach is taken within ALRM, it behaves like a classical LRM (see [Figure 6-4](#)). For slightly more advanced use, complete load models can be entered for the two matches independently. The same model as described for SOLT applies.

At the highest level, two reflects are measured per port to allow more optimized information to be obtained. When the double reflect methodology is selected, an optimization routine can be selected which can lead to a load model. The structure below is used (similar to that for the general model except no capacitance). The resistance element is assumed known (whether from DC measurements or other parametric data). The inductance and transmission line parameters can be optimized over given ranges.



**Figure 6-4.** Load Model/Characterization for LRM

The dialog box ([Figure 6-5](#) below) pertaining to this model will appear after the main calibration steps are complete. At that point, the fit model can be used (default) or modified values can be entered. A model will be suggested by the algorithm but can be overridden in this dialog.



Typical parameters - Load Model Selection

**Figure 6-5.** LRM MATCH DEVICES CALCULATED VALUES (BAND 1) Dialog Box

The dialog boxes shown above are for coaxial or non-dispersive line types.

### 6-3 LRL/LRM Calibration Step-by-Step Example

The following example presumes an MS46524B ShockLine VNA on a coaxial setup. On-wafer scenarios can be accommodated by modifying the entries in [Step 4](#) below. It is assumed that a mating reference plane pair can be created (either MF in coax or zero length-thru compatible). In this example, a full 2-Port LRM calibration is performed, although a number of other options are discussed along the way. The implications of these options are further explained in the calibration overview section.

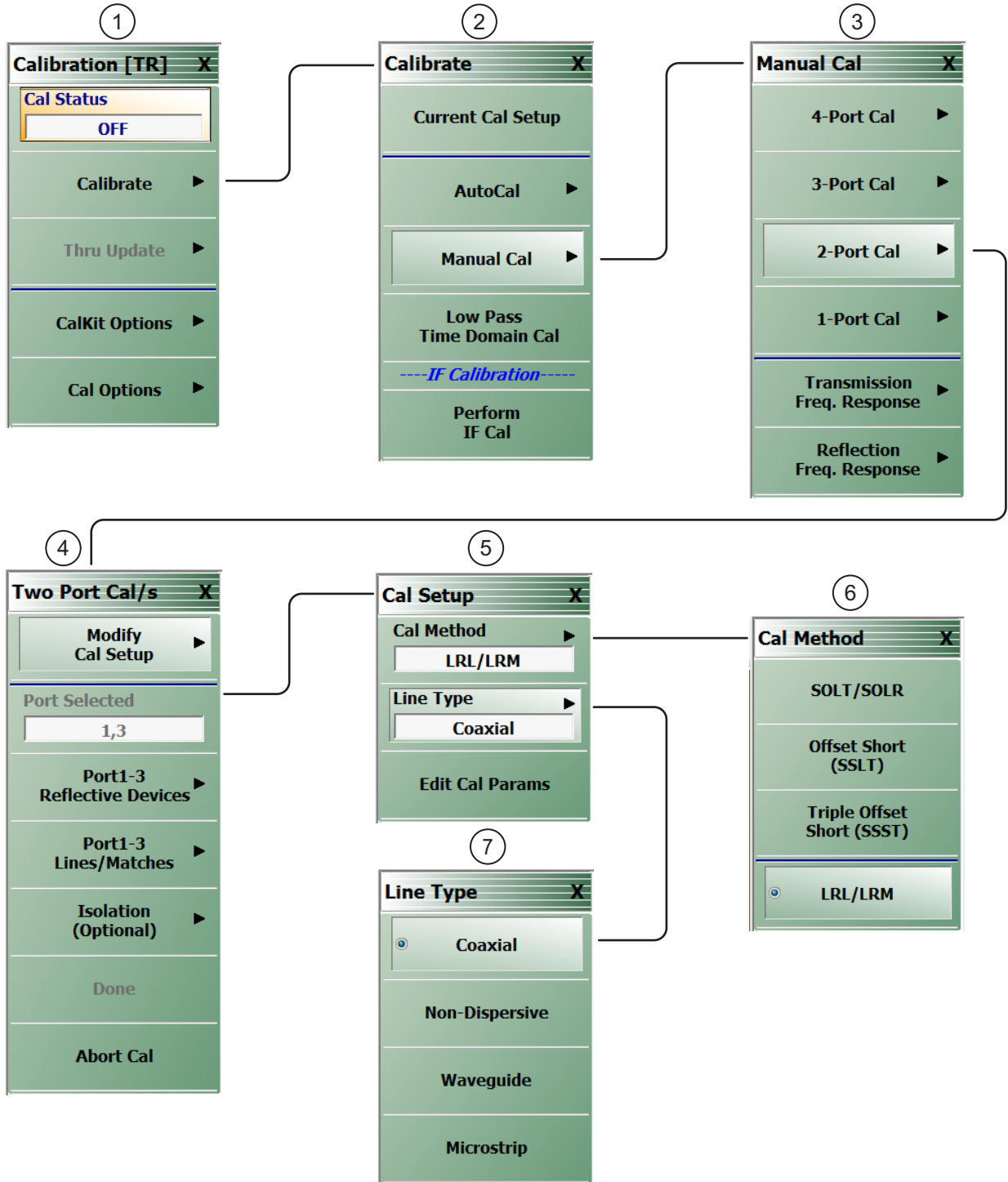


Figure 6-6. Calibration Menu Set for LRL/LRM Coaxial (1 of 2)

1. CALIBRATION menu	5. CAL SETUP menu
2. CALIBRATE menu	6. CAL METHOD menu
3. MANUAL CAL menu	7. LINE TYPE
4. TWO PORT CAL menu	

**Figure 6-6.** Calibration Menu Set for LRL/LRM Coaxial (2 of 2)

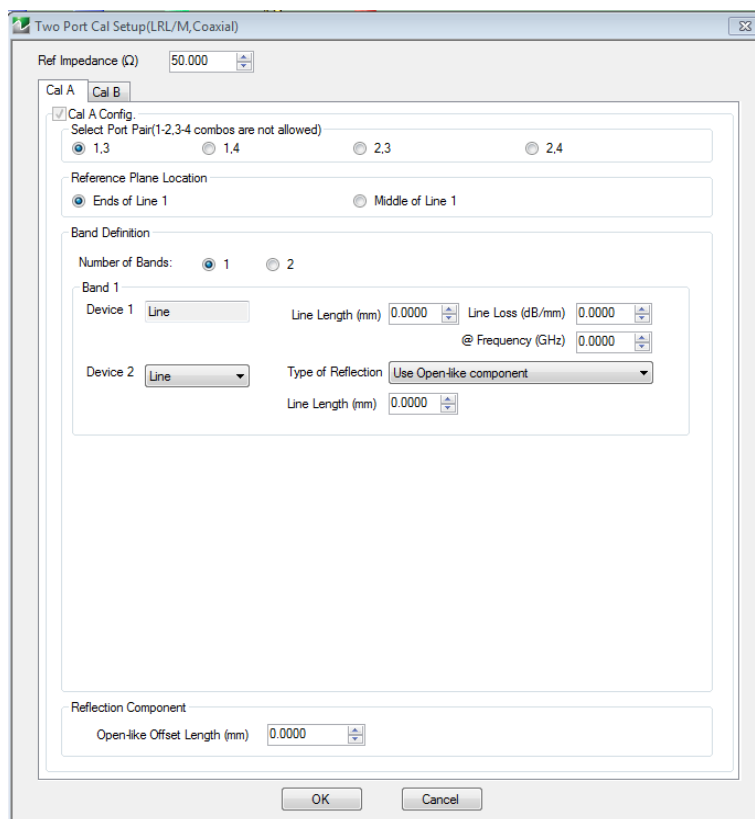
## Procedure

The same menu structure appears for Tab A and Tab B. [Figure 6-7](#)

1. Setup the desired frequency range (**FREQUENCY** menu), power (**POWER** menu) and IFBW/averaging (**AVERAGING** menu). As a default, the IFBW will be 1 kHz and the averaging will be off which is adequate for many applications. The default power level will vary depending on instrument model and options but will often be adequate for all passive and many active device measurements
2. Navigate to the TWO PORT CAL menu.
  - MAIN | Calibration | CALIBRATION | Calibrate | CALIBRATE | Manual Cal | MANUAL CAL | 2 -Port Cal | TWO PORT CAL

**Note** If a previous cal exists, the Thru Update button will be active. See for more information "[Through \(Thru\) Update](#)" on page 9-1.

3. Select Modify Cal Setup and on the CAL SETUP menu, select a Cal Method of LRL/LRM and a line type of Coaxial.
4. Select Edit Cal Params to open the TWO PORT CAL SETUP (LRL/LRM, COAXIAL) calibration components dialog box.



**Figure 6-7.** Calibration Setup Dialog - TWO PORT CAL SETUP (LRL/LRM, COAXIAL) Dialog Box

5. On the TWO PORT CAL SETUP (LRL/LRM, COAXIAL) dialog box, set the following:
  - a. The Reference Impedance establishes the impedance for the load definition, reference plane changes and Smith chart plotting. The default is 50 ohms.
  - b. Select Ends Of Line 1 as the Reference Plane Location. Since this example uses a zero length line, the choice makes no difference.
  - c. For Number of Bands, select 1. For an LRL calibration, instead of LRM as in this example, the bandwidth of the calibration will be limited by the difference in lengths between the lines. Two bands can be used (with 3 or 4 lines) to cover a larger bandwidth.
  - d. For this example, set Band 1 Device 1 to Line with a Line Length of 0 and Line Loss of 0 dB/mm. The reference frequency for the loss can be entered as 0. In general, this forces no loss scaling with frequency and the line loss value entered will be used at all frequencies.
  - e. Set Band 1 Device 2 to Match since we are performing an LRM calibration. A specific match (or load) model may be entered under Match Info, but this example uses the default of 50 ohms.
  - f. For the Type of Reflection select Use Short-like Component. This implies the impedance is usually less than the reference impedance but it need not be precise. This information is used to help in root selection. Enter the Short-like Offset Length in the Reflection Component section at the bottom of the dialog box.
  - g. Click OK to accept the entries and close the dialog box. Select Back at the bottom of the Cal Setup menu to return to the previous level TWO PORT CAL menu.
6. The menu-by-menu procedure is shown in the figure below.

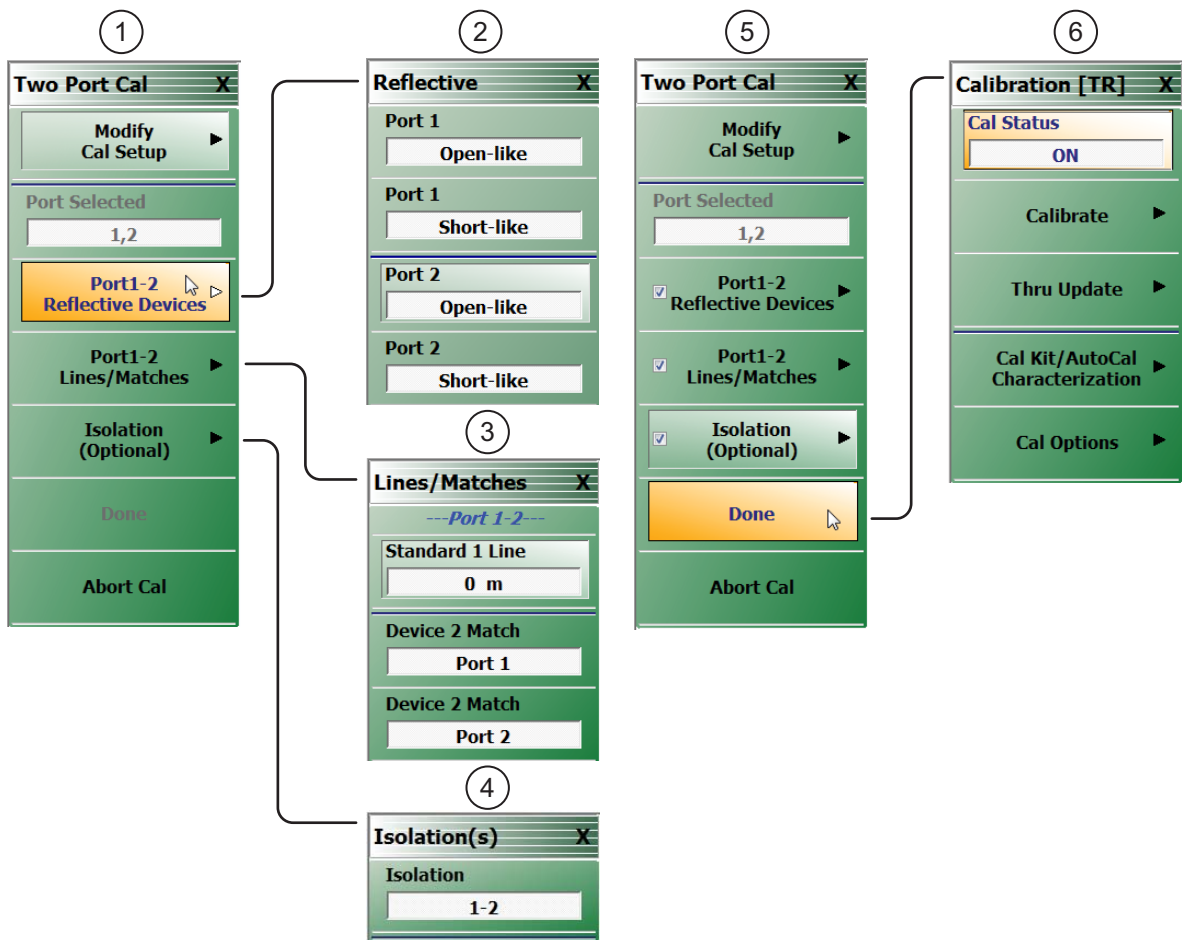


Figure 6-8. Two Port LRL/LRM Coaxial Calibration Procedure Menus (1 of 2)

1. The TWO PORT CAL menu with link/completion buttons for Port 1-2 Reflective Devices, Port 1-2 Lines/Matches, and Isolation (Optional).	4. Optional ISOLATION Port 1-2 Menu
2. REFLECTIVE Port 1-2 Menu	5. TWO PORT CAL menu after all calibration procedures successfully completed. Note Done button is available.
3. LINES/MATCHES Menu	6. CALIBRATION Menu with Cal Status set to ON.

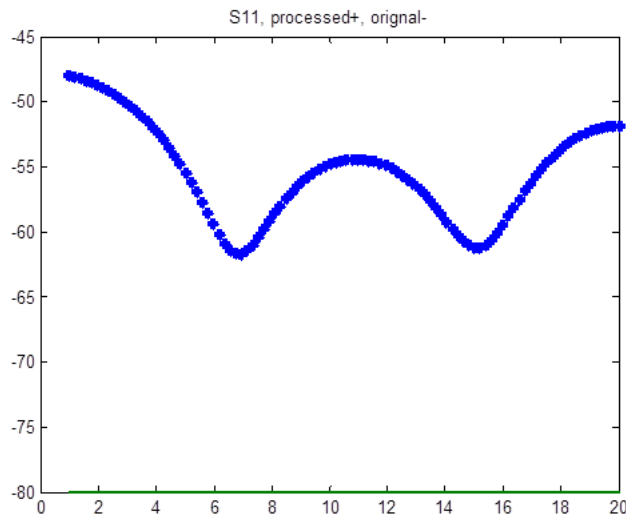
**Figure 6-8.** Two Port LRL/LRM Coaxial Calibration Procedure Menus (2 of 2)

7. On the TWO PORT CAL menu (above in [Figure 6-8 – #1](#)), select the Port 1-2 Reflective Devices button and its linked REFLECTIVE menu ([Figure 6-8 – #2](#)). In this example, the short-like reflective device must be measured at both ports. After the device is connected to a given port, click the corresponding button (a check mark will then appear after the measurement). Click on Back when done with this step to return to the TWO PORT CAL menu.
8. Connect the reference planes together to form the 0 (zero) length line. Select Port 1-2 Lines/Matches and on the LINES/MATCHES menu ([Figure 6-8 – #3](#)), click on Device 1 Line (0m). Sequentially connect the load (or loads if two models were entered for two physically separate loads) and click the corresponding buttons. For this example, repeat for **Device 2 Match at Port 1** and then **Device 2 Match at Port 2**. As before, check marks will appear when a given step is completed. Click BACK when completed and then DONE.
9. An optional isolation step using the Isolation (Optional) button and the linked ISOLATIONS menu (above [Figure 6-8 – #4](#)) is available but is generally not recommended. If desired, terminate **Port 1** and the end of the cable attached to **Port 2** before clicking on the Isolation 1-2 button.
10. When all procedures are complete (at [Figure 6-8 – #5](#)), the Done button on the TWO PORT CAL menu is available. Click on Done. The focus returns to the CALIBRATION menu (at [Figure 6-8 – #6](#)) where the Cal Status button is set to ON.

## 6-4 Hints and Suggestions

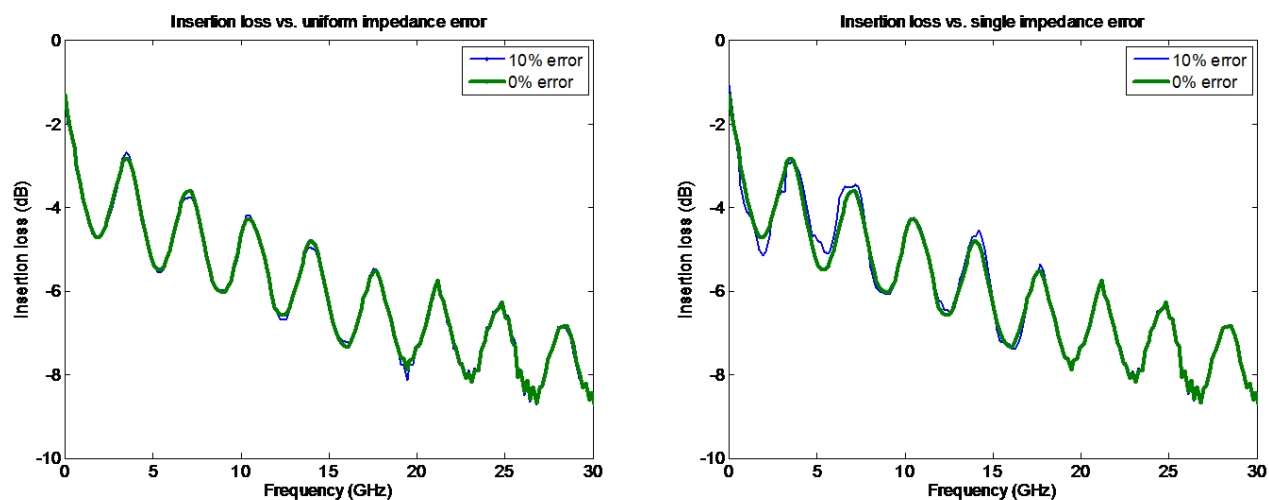
Since there are a number of choices involved in setting up the LRL/LRM family of calibrations, some additional hints and points of emphasis may be of assistance:

- Reflect offset lengths are referenced to the ends of Line 1. These lengths are all air-equivalent lengths. The line length entries for the transmission lines are also air-equivalent. If the lengths are known in terms of time delay, the air-equivalent length is given by:
 
$$\text{time delay (seconds)} \times 2.9978 \times 10^8 \text{ (m/s)}$$
- The frequency breakpoint for 2-band calibrations is calculated from the geometric mean of the theoretical upper limit of the low band and the theoretical lower limit of the upper band. The former is calculated based on the 160 degree delta frequency and the latter is calculated from the 10 degree delta frequency. This decision is somewhat arbitrary and is heavily dependent on the materials involved and uncertainties required. With relatively lossy lines, one can approach the limits more closely than with low-loss lines. The impact is also dependent on transmission line quality. If both lines have an impedance of, for example, 50.1 ohms and one measured a theoretical  $-80$  dB termination, the result would be predictable limited by the line impedance imperfection to about  $-61$  dB at all frequencies. If instead, one line was 50.1 ohms and one was 50.2 ohms, then one gets progressively more effect near the theoretical edge frequencies as shown in the figure below.



**Figure 6-9.** The effect of line impedance problems gets magnified as the line length delta approaches the theoretical band edges (the result for a high RL termination measurement when calibrated with unequal line impedances is shown here). This should be considered when deciding on the 2-band breakpoint frequency.

- When doing two band TRL/LRL calibrations, the orientation of the lines between bands can sometimes be confusing. The larger line delta should always be in band 1 (the lower frequency section).
- The TRL family of calibrations is more sensitive to asymmetries in standards (for example: different reflects on the two ports, lines of different impedance) than to problems in the standards themselves. When creating a custom calibration kit, this can be an important point. As an example, the effect on the measurement of a mismatched delay line is shown in [Figure 6-10](#) when there was a global 10 % impedance error on the LRL calibration lines and when the error was on only one line.



**Figure 6-10.** TRL/LRL is more sensitive to differences between the line impedances than to the absolute line impedance (although problems on that will shift the reference impedance of the calibration).



# Chapter 7 — Receiver Calibrations

## 7-1 Receiver Calibration Overview

The purpose of this section is to show how receiver calibrations can be set up, and how some of the additional receiver calibration utilities can be used.

Unlike conventional VNA RF calibrations (like SOLT, LRL/LRM, and others) that are used to calibrate the VNA for S-parameter measurements, the receiver calibration is more of an absolute power calibration to help with measurements such as:

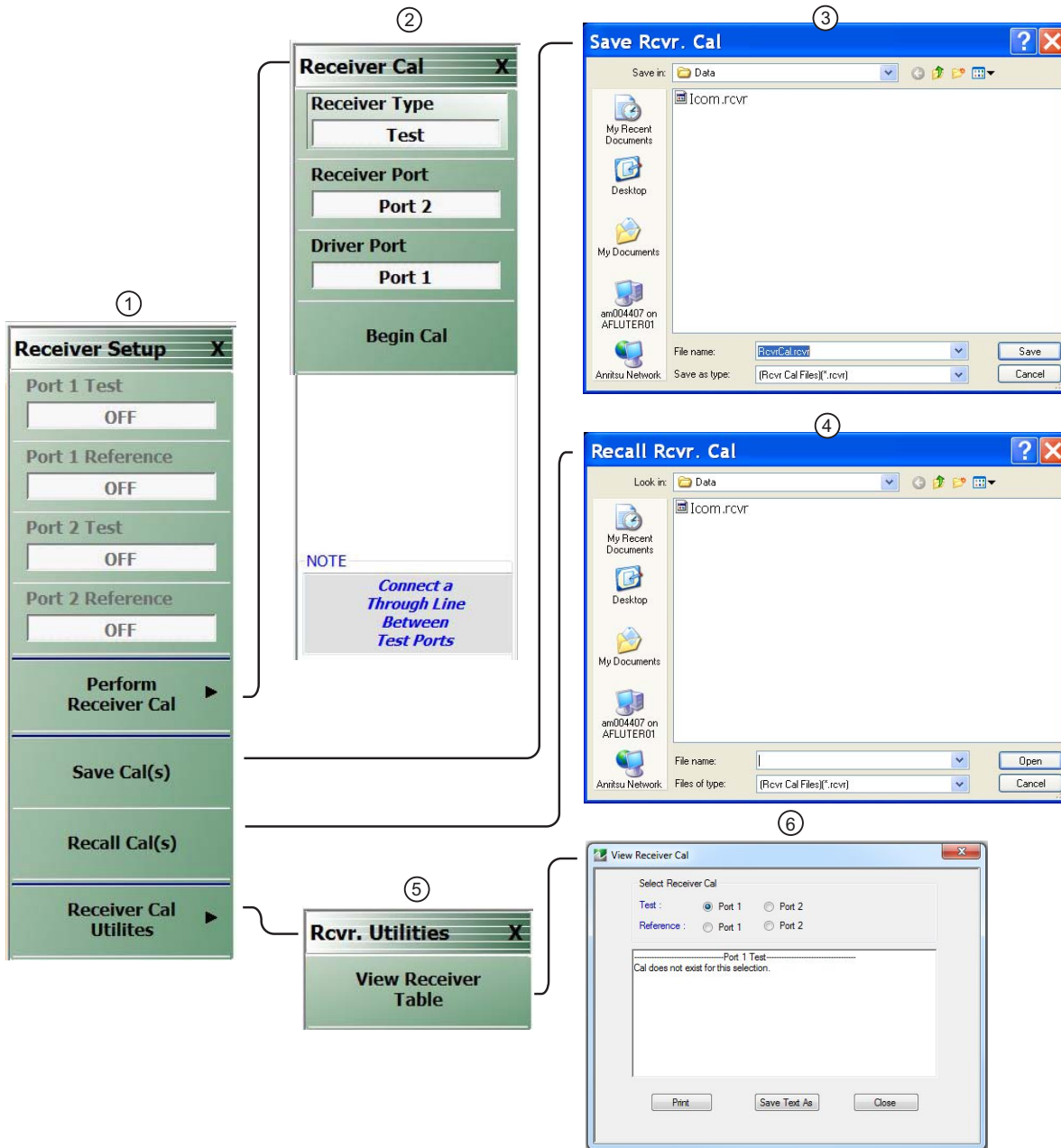
- Mixer conversion loss (in the simpler scalar cases)
- Other times when the VNA is just used as a channelized receiver

## 7-2 Receiver Calibration Concepts

The concept of the receiver cal is to take a known source power at some source reference plane and transfer that knowledge to the receiver at a desired receiver reference plane. If it is convenient to use the test port as the source reference place, the built-in factory ALC calibration can be used to establish the power knowledge. If this is not convenient (because of frequency translation or some other network is required, or greater accuracy is needed), then a power calibration can be performed with the help of a GPIB-controlled power meter to better establish that power knowledge. Power calibrations are covered in more detail in the *Sweep Types* portion of this *Measurement Guide* and in the *Operation Manual*.

In all of these discussions, power refers to signal amplitude at the fundamental frequency. Since the receivers are all tuned, they are not measuring full integrated power as in a power meter. This can be important as will be discussed in the *Uncertainties* section.

The receiver calibration menu system begins under the Power menu (since it is associated with power reference planes rather than S-parameter calibration). The Receiver Setup menu for the MS46522B is shown in [Figure 7-1 on page 7-2](#). The Receiver Setup menu for the MS46524B is shown in [Figure 7-2 on page 7-3](#).

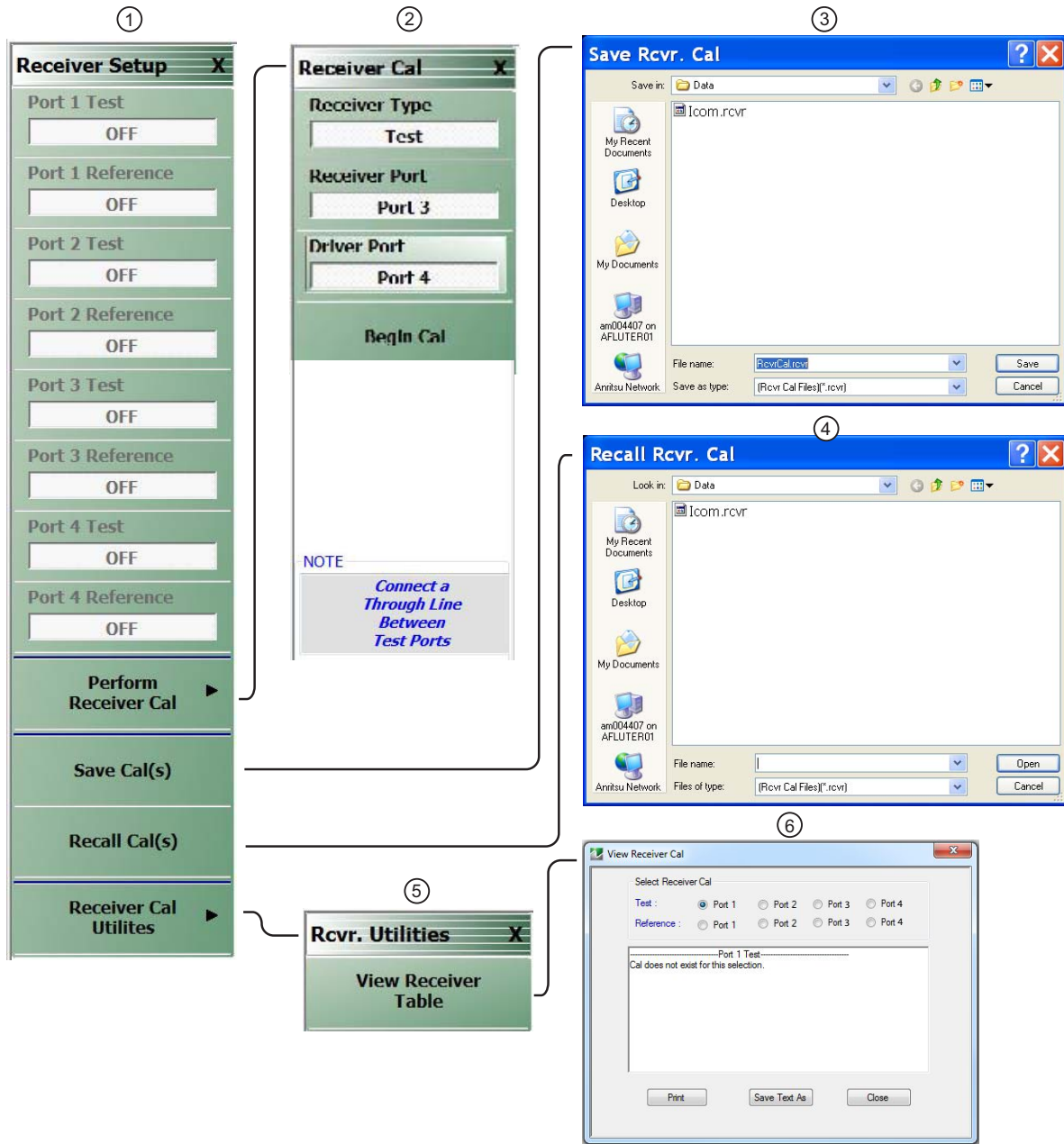


- 1. RECEIVER SETUP menu  
MAIN | Power | POWER | Receiver Cal | RECEIVER SETUP
- 2. RECEIVER CAL (CALIBRATION) menu

- 3. SAVE RCVR. CAL dialog box
- 4. RECALL RCVR. CAL dialog box
- 5. RCVR UTILITIES menu
- 6. VIEW RCVR CAL dialog box

**Figure 7-1.** MS46522B RECEIVER SETUP Menu

There are four different receiver calibrations possible (since there are four receivers in the MS46522B) and they can be activated at the top of this menu. A menu item will be active only if that calibration exists. The calibrations can be saved and recalled from this menu. Calibrations can also be saved and recalled as part of the global setup save using the commands located under the File menu.



1. RECEIVER SETUP menu  
 MAIN | Power | POWER | Receiver Cal |  
 RECEIVER SETUP

2. RECEIVER CAL (CALIBRATION) menu

3. SAVE RCVR. CAL dialog box

4. RECALL RCVR. CAL dialog box

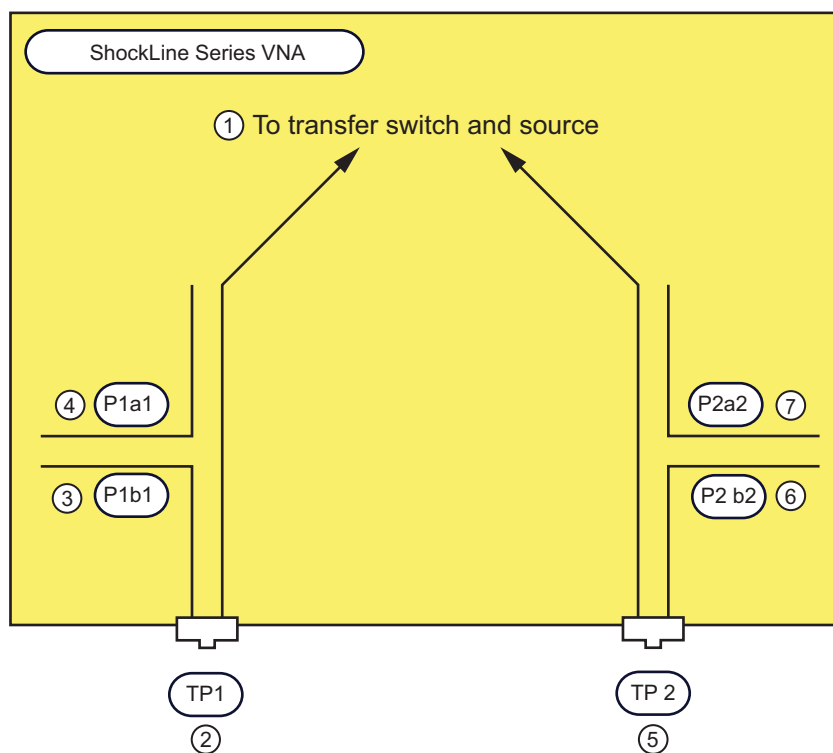
5. RCVR UTILITIES menu

6. VIEW RCVR CAL dialog box

Figure 7-2. MS46524B RECEIVER SETUP Menu

## 7-3 Setting Up Receiver Calibrations

To get started, it will help to take a closer look at the architecture of the MS4652xB ShockLine as suggested by [Figure 7-3](#).



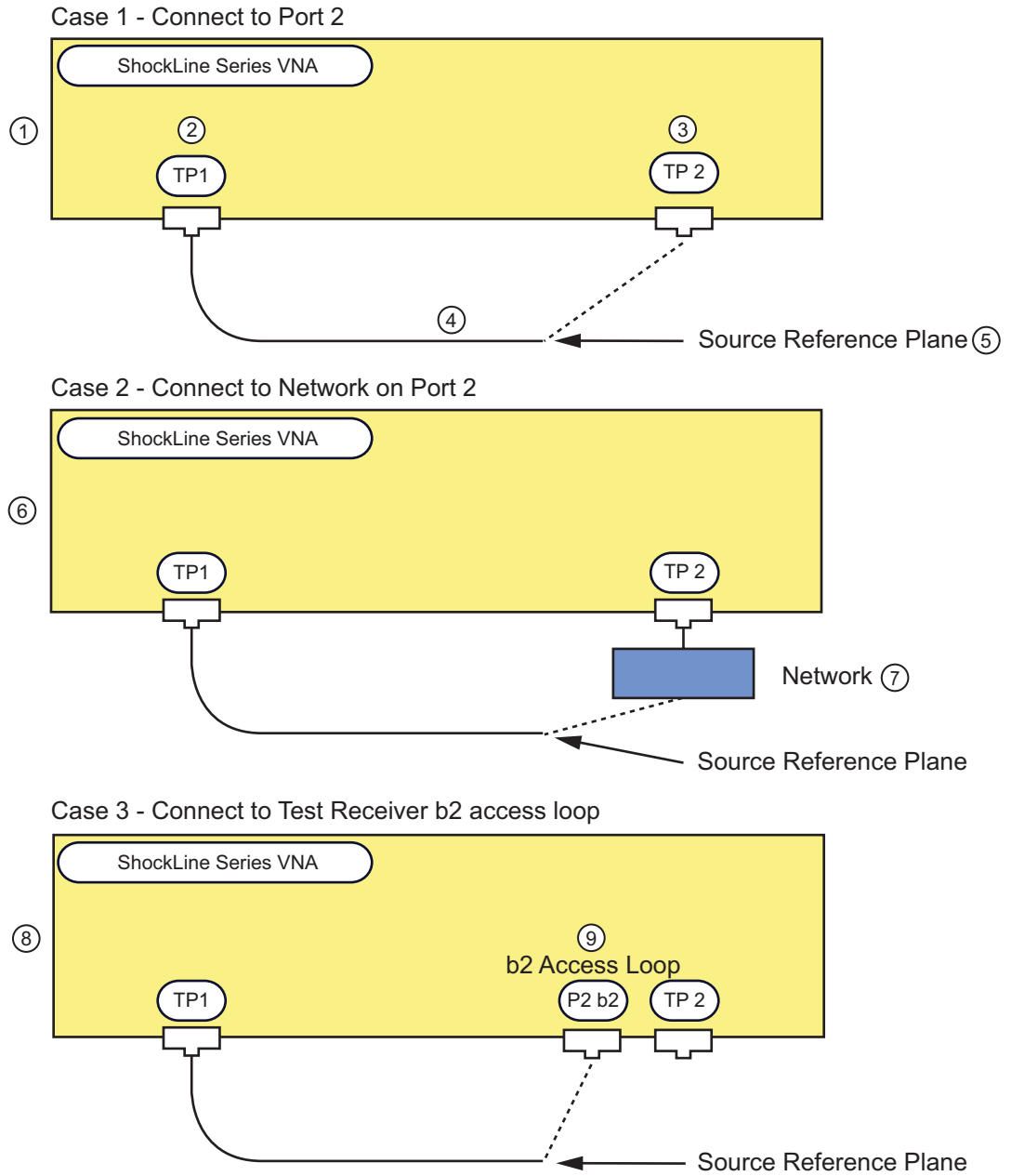
- |                                      |                                      |
|--------------------------------------|--------------------------------------|
| 1. To transfer switch and source.    | 5. TP2 – Test Port 2                 |
| 2. TP1 – Test Port 1                 | 6. P2b2 – Reference Receiver Port a2 |
| 3. P1b1 – Reference Receiver Port a1 | 7. P2a2 – Test Receiver Port b2      |
| 4. P1a1 – Test Receiver Port b1      |                                      |

**Figure 7-3.** Simplified Block Diagram of the MS4652xB ShockLines

As this is a 2-Port VNA, there are four unique receivers that are performing the measurements: a reference receiver associated with each port (a1 and a2) and a test receiver associated with each port (b1 and b2). An absolute power calibration, which is the receiver calibration, can be associated with each of these receivers.

Note that although the receivers are shown here as associated with couplers, this need not always be the case. With Option 51, loops are in place between the coupler arms and the receivers allowing direct access to those receivers. This brings up the point of receiver reference planes. The receiver calibration will establish an absolute power reference but how the calibration is setup will establish where the reference is being established.

Consider the three cases shown in Figure 7-4. The use of three different receiver reference planes is shown. Where the known source power reference plane is connected for the receiver calibration establishes where that power knowledge is transferred to.



**Case 1 – Port 2 Direct**

1. Case 1 – Connect to Port 2
2. Test Port 1
3. Test Port 2
4. Test Cable (f-m)
5. Source Reference Plane

**Case 2 – Network Connected to Port 2**

6. Case 2 – Connect to Network Connected to Port 2
7. Network attached to Port 2

**Case 3 – Port 2 b2 Access Loop**

8. Case 3 – Connect to Port 2 b2 Access Loop
9. Port 2 b2 Access Loop – Requires VNA equipped with Option 51.

**Figure 7-4.** Three Different Receiver Reference Planes

In all of the cases, the source reference plane (where the power is accurately known) is at the end of the dashed cable. This will be connected in different places in the three cases thus establishing the receiver reference plane in three different places. In this case, the absolute power reference has been transferred to (all referring to the Port 2 Test, or b2 receiver calibration in this example set):

- **Case 1**  
To Port 2
- **Case 2**  
To the input of a network connected to Port 2 (could be a pad, a cable assembly, a switch matrix)
- **Case 3**  
To the direct access loop input to the b2 receiver

All of these may be valid receiver reference planes depending on where one wants to connect the DUT (and, more precisely, where one wants to measure power).

The source reference plane is any plane where one accurately knows the signal level. The factory ALC calibration establishes that knowledge at the test ports with moderate accuracy (on the scale of 1 dB). It may be that greater accuracy is needed or it may be that this plane is inconvenient:

- **Cable**  
A cable is needed to reach the receiver reference plane and it is not desired that this cable loss be neglected
- **Preamplifier**  
A preamplifier is needed before the DUT and it is desired that this power level form the reference (if, for example, the receive-side network has very large loss and one wants a better signal-to-noise ratio for the receiver cal)
- **Other**  
Other reasons

For these cases, a power calibration using controlled power can be performed at the desired source reference plane prior to performing the receiver calibration. Over reasonable periods of time, the power calibration accuracy can be on the order of 0.1 dB. Aspects of the power calibrations are discussed in the *Sweep Types* section of the **Measurement Guide** and in the **Operations Manual**.

A key point in establishing the source reference plane is that the receiver calibration needs to be informed of what that power level is. This is done through the power menu. The value entered there is used as the power reference. When using the factory ALC calibration at the port, this link is obvious. When using a power cal at some other reference plane, the power entry field on the power menu is also now linked to that reference plane. Thus in both cases, the correct power value is transferred to the receiver cal.

The relationship between the power entry fields and the Target Power field of the power calibration is important. First a few definitions:

**ALC entry field:**

Where the requested power is entered on the main Power menu for Port 1, Port 2, etc.

**Effective power field:**

The read-only fields below the ALC entry fields. These normally play an additional role when power calibrations are active.

**Target power field:**

The entry area on the Power Cal submenu where the objective of the power calibration is entered.

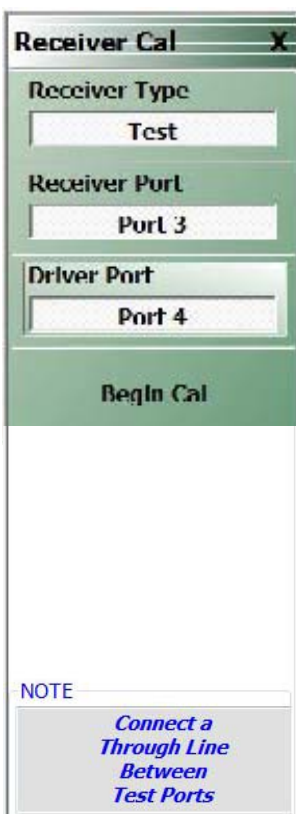
The normal procedure is to enter the desired power at the user reference plane (where the power sensor will be connected for the power calibration). If the gain/loss between the VNA port and the user reference plane is small, the ALC entry field can be set to the same value as the Target Power. If the gain/loss is significant, the ALC field should be offset by an estimate of that gain/loss (ALC entry field should be higher if it is a loss, and lower if it is a gain). This offset need not be extremely accurate; it serves to inform the system of where roughly to set the internal sources in order to achieve the desired user reference plane power. After the power calibration is completed, the Effective power field will match the Target power. If the ALC entry field is later changed (from the value at the time of the calibration), the Effective power field will also change to reflect an estimate of the new user reference plane power. This new value is only an estimate since the calibration was not performed at that power level and the accuracy will decrease as the change from the calibrated level increases.

**Example:**

Target power is  $-20$  dBm and there is about 8 dB of loss from the VNA port to the desired reference plane.

1. Set Target Power to  $-20$  dBm and set the ALC entry field (for that port) to  $-12$  dBm. Perform the power calibration.
2. After the calibration is successfully completed, the Effective power will read  $-20$  dBm and the ALC entry field will remain at  $-12$  dBm.
3. Change the ALC entry field to  $-15$  dBm. The Effective power field will change to  $-23$  dBm (the estimate of the new power at the reference plane).
4. Turn the power calibration off. If the ALC entry field is still at  $-15$  dBm, the Effective power field will change to also be at  $-15$  dBm. With the power calibration no longer applied, the system's best estimate of the power being applied is that based on the internal power calibration.

Now that the setup is physically ready, the execution of the receiver calibration is performed from the menu in [Figure 7-5](#).



**Figure 7-5.** RECEIVER CAL (CALIBRATION) Menu

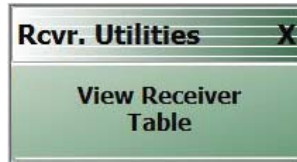
The first two menu items describe which receiver is being calibrated and the third describes the driving port and, hence, the source reference plane. Once the source and receiver reference planes are connected, the **Begin Cal** button can be selected. The note indicates that a thru line should be connected between ports but what is really meant is that the source and receiver reference planes should be connected together.

During the calibration, different parameters will be displayed as the system collects the appropriate receiver data. Once complete, the calibration will be activated as shown in the [Figure 7-1](#) menu.



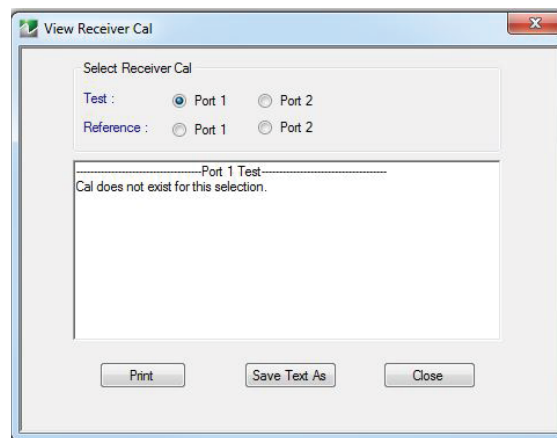
## 7-4 Receiver Calibration Utilities

The RCVR UTILITIES (Receiver Utilities) menu is shown in [Figure 7-6](#).



**Figure 7-6.** RCVR (RECEIVER) UTILITIES Menu

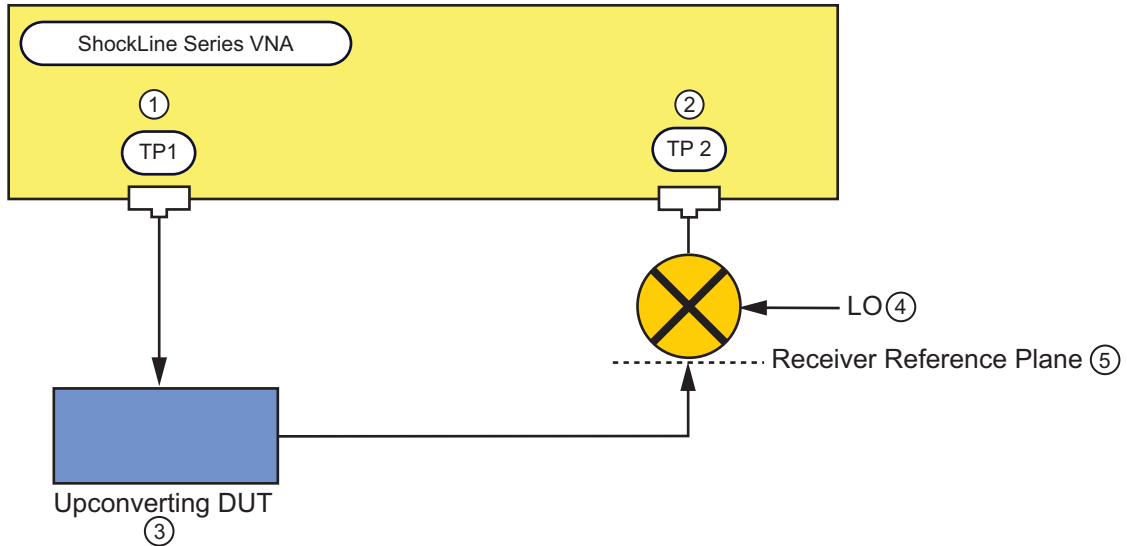
The View Receiver Table button displays the calibration values. This is sometimes valuable as a troubleshooting aid or to gain some more insight into the signal levels in a particular setup. An example Receiver Calibration Table is shown in [Figure 7-7](#). In this example, the table refers to the port 2 test calibration (b2).



**Figure 7-7.** VIEW RCVR CAL (RECEIVER CALIBRATION) Dialog Box – Typical Receiver Calibration Table

The receiver calibration is indexed to frequency at the receiver so two vectors of data are key (first two columns). The power level used in the calibration is also shown in the third column as a reference.

The frequency index vector brings up an important point when using receiver calibrations with multiple source mode and certain other frequency conversion modes. It is important that the frequency index match the frequencies present at the receiver reference plane so that the computations can be performed correctly. Consider the setup shown in Figure 7-8 that uses multiple source control (see separate section in this measurement guide and multiple source application notes for more information).



1. Test Port 1	4. LO (Local Oscillator)
2. Test Port 2	5. Receiver Reference Plane
3. Upconverting DUT	

Figure 7-8. Example of a Frequency-Translated Receiver Reference Plane

The DUT in this case is up converting (for example, to mm-Wave frequencies) and a down converter is used to bring the DUT output back to within range of the MS4652xB ShockLine. To measure the DUT output power, the receiver reference plane must be in the mm-Wave zone and the frequency list should be referenced here. The receiver source equation in multiple source mode can be used to help here.

The proper indexing can be established using the Receiver Source equation in the multiple source table (Figure 7-9).

- MAIN | Application | APPLICATION | Multiple Source Setup | MULTIPLE SOURCE

Band #	Start Freq	Stop Freq	Src = (M/D) * (F + OS); Src CW = (M/D) * OS	CW ON	Multiplier (M)	Divisor (D)	Offset Freq (OS)
1	10 MHz	70 GHz	Internal Source	<input type="checkbox"/>	1	1	0 Hz
			External Source 1 ( Inactive )	<input type="checkbox"/>	1	1	0 Hz
			External Source 2 ( Inactive )	<input type="checkbox"/>	1	1	0 Hz
			External Source 3 ( Inactive )	<input type="checkbox"/>	1	1	0 Hz
			External Source 4 ( Inactive )	<input type="checkbox"/>	1	1	0 Hz

Figure 7-9. Receiver Source Equation From Multiple Source Mode

The purpose of this equation is to provide the proper frequency index for the receiver calibration. See the multiple source section for more details

A final utility controls the interaction between the receiver calibration and ratioed S-parameters. Typically, the receiver calibration pertains to non-ratioed measurements so the correction is not applied to the non-ratioed variables prior to forming the S-parameter ratios. This is done to avoid the confusion of the receiver calibrations interacting with the regular S-parameter calibrations (SOLT, LRL/LRM). The application of the receiver cal is, by default, off for ratios. If desired, the application of the receiver cal to the S-parameter ratios can be turned on (to allow off-line ratio comparison for example) but performing a receiver calibration after an S-parameter calibration will invalidate the S-parameter calibration (as well as trace memory comparisons and other measurements).

## 7-5 Receiver Calibration Uncertainties

The uncertainty in a receiver calibration is important since it forms a bound on possible uncertainty in many of the measurements listed in the introduction. Since there are many possible setups, we cannot provide a blanket result but can show how this uncertainty can be computed.

### Source Side

- Power calibration accuracy (assuming it is used): set by the power meter/sensor and mismatch between the power sensor and the source reference plane.

### Receiver Side

- Mismatch between source reference plane and receiver reference plane
- Linearity of the receiver
- Trace noise of the receiver



# Chapter 8 — Adapter Removal Calibration and Network Extraction

## 8-1 Introduction

This chapter describes various methods for handling cases of non-insertable DUTs. In some coaxial cases, this can be handled with a special class of adapter removal calibrations. More generally, de-embedding can be used to remove the effects of fixtures or adapters required to execute the measurement. The de-embedding process itself will be covered in a later chapter but the means of evaluating the network to be de-embedded will be addressed here.

While it is usually desired to perform a 2-Port calibration with mating connectors of the same type, this is sometimes not possible based on the connectors of the device to be tested. Examples of this include:

- The DUT has one N port and one GPC-3.5 port
- The DUT has two female SMA ports and it is not desired to use a non-zero length thru
- The DUT has one fixtured port and one SMA port
- The DUT has one waveguide port and one coaxial port

What these examples share is that completing the through line between the effective test ports requires some kind of adapter or fixture. Since the adapter has some phase length, loss, and mismatch, its effects should be removed for a high quality calibration. Adapter removal is a utility to characterize this adapter and remove its effects from a calibration.

In the more general case of de-embedding, a means of determining the network to be de-embedded must be available. Techniques similar to adapter removal, that is a measurement using one or more calibrations, can be used to extract these parameters. As such network extraction can be viewed as a generalization of adapter removal.

## 8-2 Two Related Sets of Reference Planes

The concept of the adapter removal relies on the existence of two related sets of reference planes with one set on either side of the adapter (see [Figure 8-1](#) below). Assuming one can perform a full calibration at each set of reference planes, there is enough information to extract the behavior of the adapter itself. When the calibration is being performed at the reference planes on the left (between Ports 1 and 2'), the adapter behavior is embedded in the characteristics of Port 2'.

Similarly, when the calibration is being performed between Ports 1' and 2, the adapter behavior is embedded in that of Port 1'. Since each of these two calibrations involve mating connector types, these are far easier to perform than the direct 1-2 calibration. It will not be shown here, but the use of the two calibrations provide nearly enough information to extract the parameters of the adapter itself. Figure 8-1 shows the structure of the adapter removal calibration. Two calibrations are performed at the two sets of reference planes shown (between Ports 1 and 2', and between 1' and 2), which allows a determination of the adapter behavior. After the adapter removal, the resulting calibration will be between Ports 1 and 2.

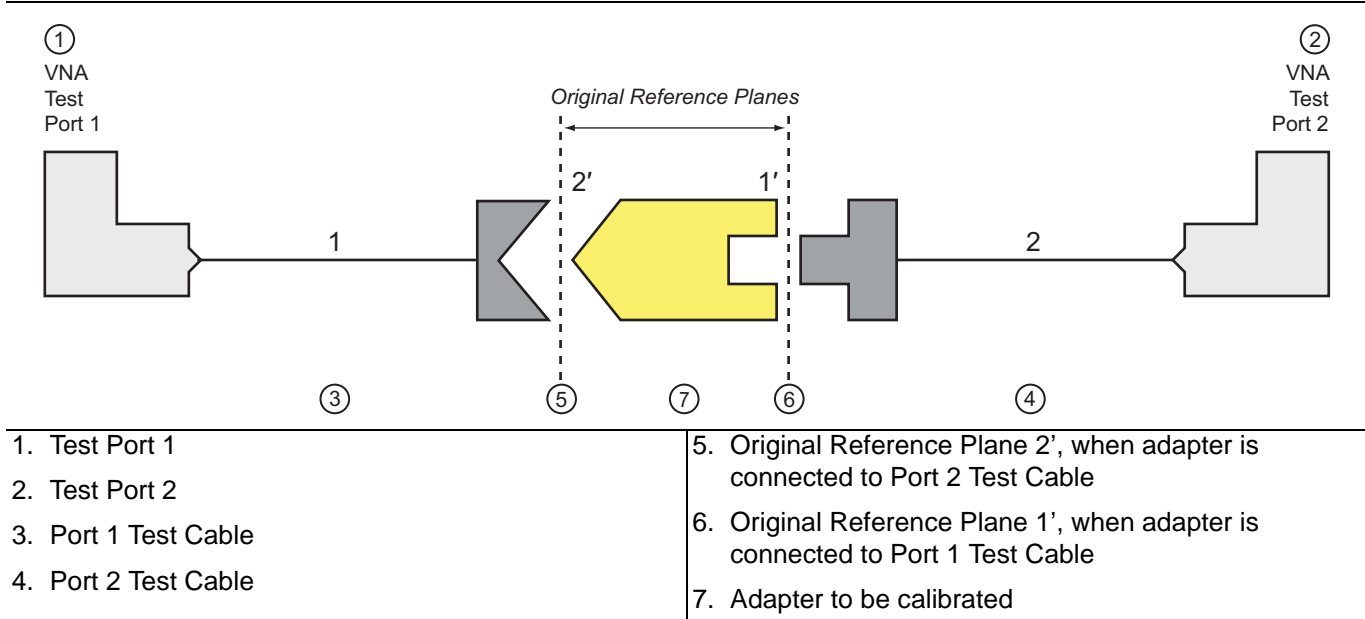


Figure 8-1. Adapter Removal Block Diagram

## Caveats and Limitations

There are two caveats to this procedure.

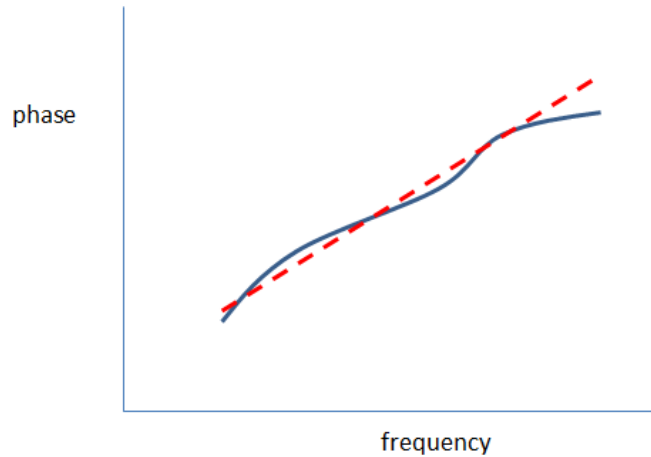
First, only the  $S_{12}S_{21}$  products of the adapter can be determined from this procedure, not the two transmission terms individually. However, since only the product is needed to de-embed the adapter effects, this is not much of a problem. Most adapters are passive and reciprocal anyway, so the individual terms could be determined if necessary.

Second, there is a complex square root operation involved, so a root determination is necessary. To help this, the user must enter a guess as to the electrical length of the adapter (in ps of delay). The guess need not be very accurate, just within the correct half plane. At 2 GHz, this means the error in delay entry should be less than 125 ps to ensure the correct root is selected.

In general the error must be less than  $\frac{1}{(4f)}$  where  $f$  is the highest frequency being used.

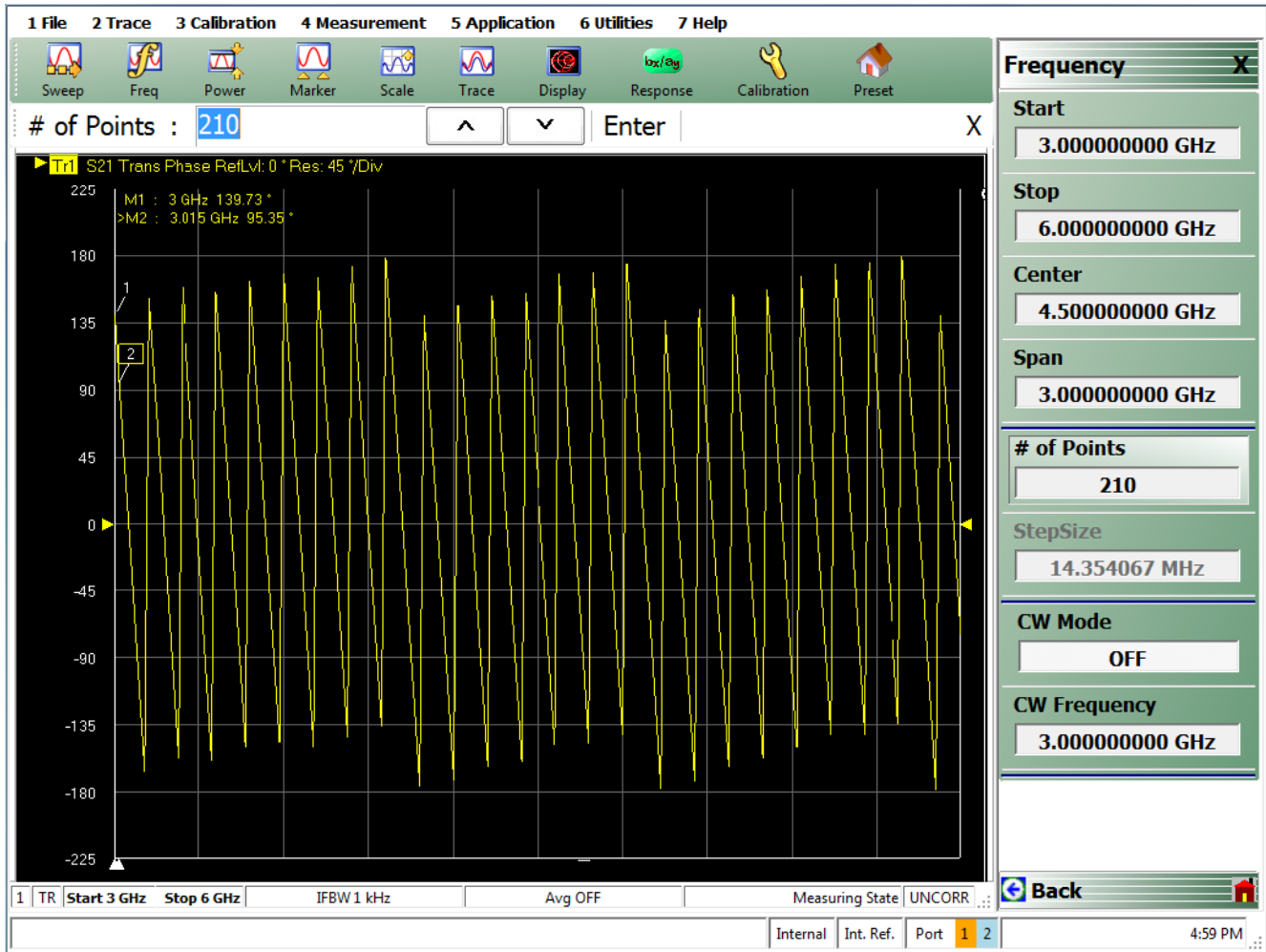
One can enter 0 for the length estimate to force the software to do length estimation internally. This calculation is based on the phase change between frequency points towards the lower end of the sweep range. A linear fit to the phase function is performed and the slope is used to estimate the electrical length as suggested by [Figure 8-2](#). This procedure is quite accurate unless the frequency step size is large relative to the phase change in the measurement. Thus, if the setup uses very long cables, it may help to increase the number of frequency points or at least look at a raw  $S_{21}$  phase display (no calibration applied with something of modest insertion loss connected) and see how often the phase wraps.

---



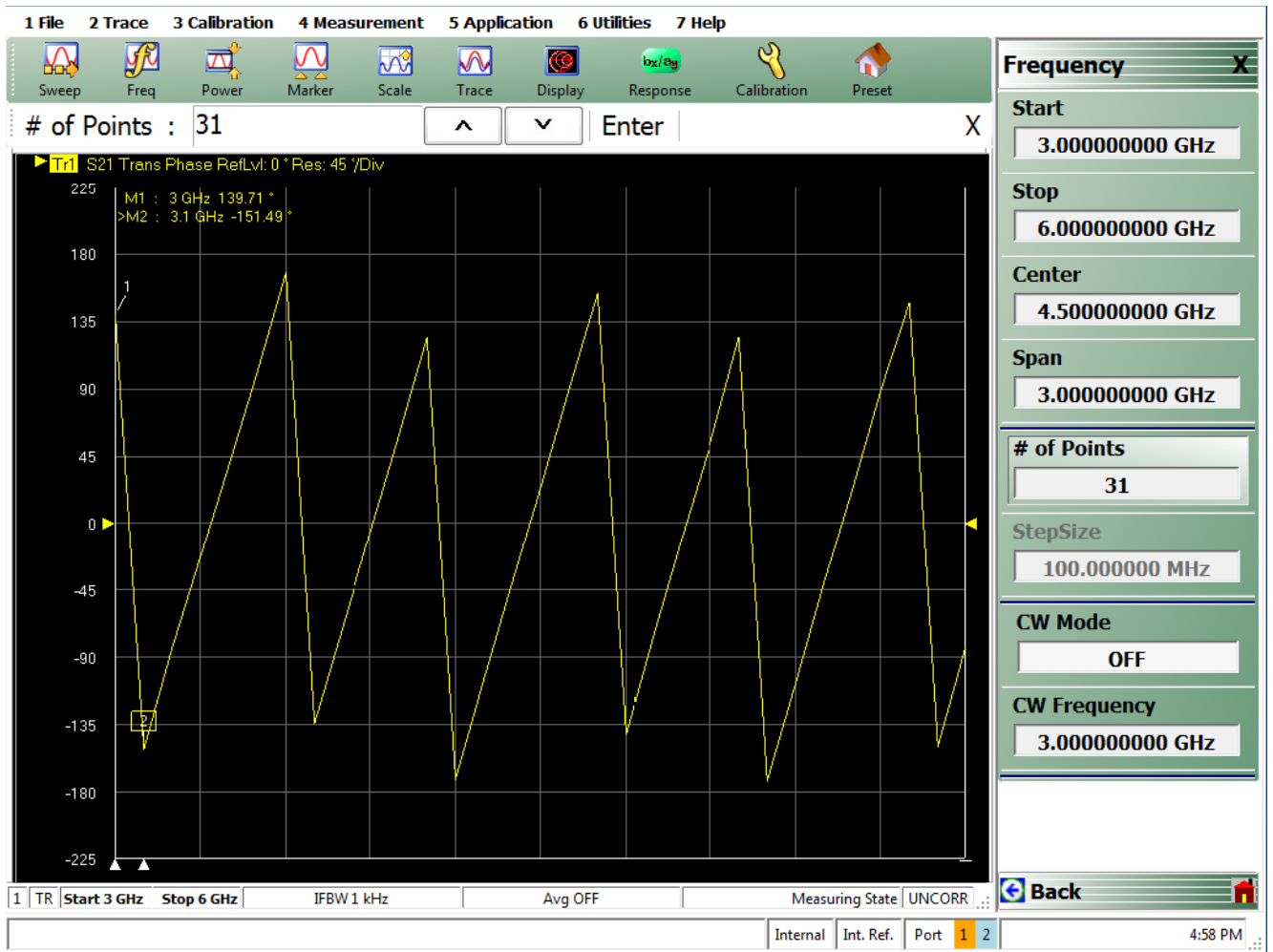
**Figure 8-2.** By entering 0 as the length estimate, the software calculates a length estimate for you. If the frequency step size is large relative to the electrical length of the setup, this may not be advisable.

In the upper half of Figure 8-3, one can see how the first frequency step size would be adequate for this setup. The phase change between points is well below 180 degrees so linear fitting will not run into aliasing problems. In the second setup (next page), the phase change between points is nearly 360 degrees so one may start to run into aliasing issues with the 0-entry-length-estimation. For this case, the point count should be increased at least somewhat or a manual length entry can still be used in Adapter Removal.



**Figure 8-3.** Uncalibrated phase plots from an example setup are shown here for two different step sizes. In the second case, the automatic length estimation may run into aliasing problems if much more length is added. (1 of 2)

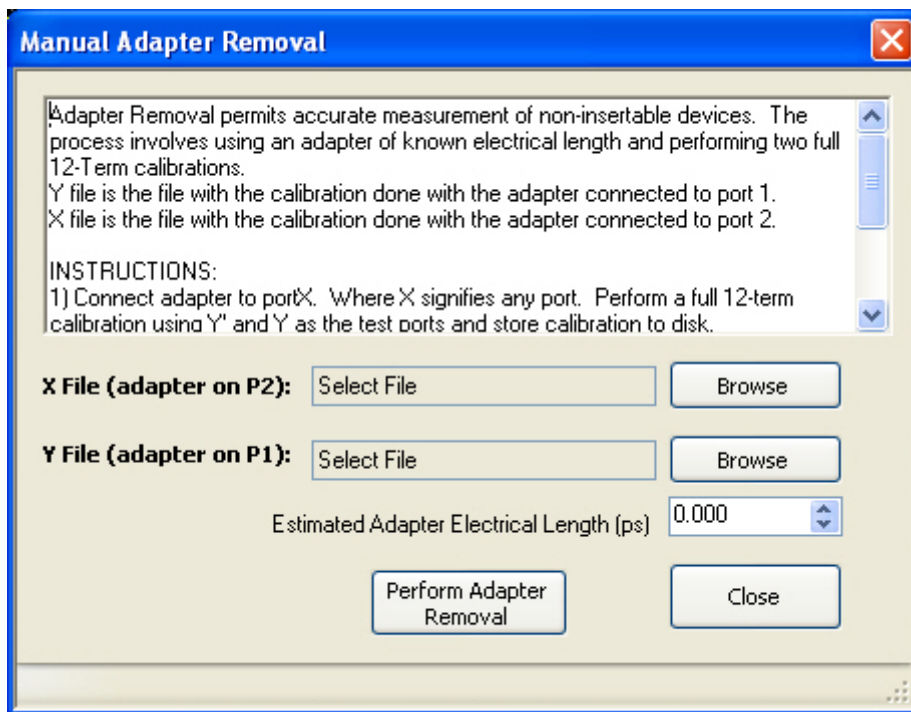




**Figure 8-3.** Uncalibrated phase plots from an example setup are shown here for two different step sizes. In the second case, the automatic length estimation may run into aliasing problems if much more length is added. (2 of 2)

## 8-3 Performing an Adapter Removal

Two full 2-Port calibrations must be performed and those calibrations (plus front panel setups) must be stored to the current directory on a USB memory device or hard disk. The setups for the two calibrations should be the same in terms of frequency range and number of points. Upon entering the adapter removal utility, an estimate for the electrical length of the adapter must be entered as well as the location of the two calibrations. Once this is done, the utility will generate and apply a new calibration by removing the adapter effects. The menu and help screen for this procedure are shown below (Figure 8-4).



**Figure 8-4.** MANUAL ADAPTER REMOVAL Dialog Box - 2-Port VNAs

## Example Adapter Removal

The following example should help illustrate the use of the adapter removal utility. An adapter was constructed with about 3 dB of loss and 180 degrees of phase shift at 3 GHz. This leads to an estimate of the delay length of:

$$\phi = \omega\tau \quad \tau = \frac{\theta}{\omega} = \frac{\pi}{2\pi(3 \times 10^9)} \approx 167\text{ps}$$

### Equation 8-1

Since the loss of this adapter is substantial, one could not simply use reference plane extensions to remove the phase shift and hope for an accurate result.

The two calibrations described earlier were performed and stored to the hard disk and the adapter removal was executed. A through was then connected without the adapter in place. Normally this would not be possible (since the whole reason for using the adapter removal was for situations when a thru would be difficult), but this example adapter was constructed just to show that the algorithm functions correctly. The results are shown in below (Figure 8-5).

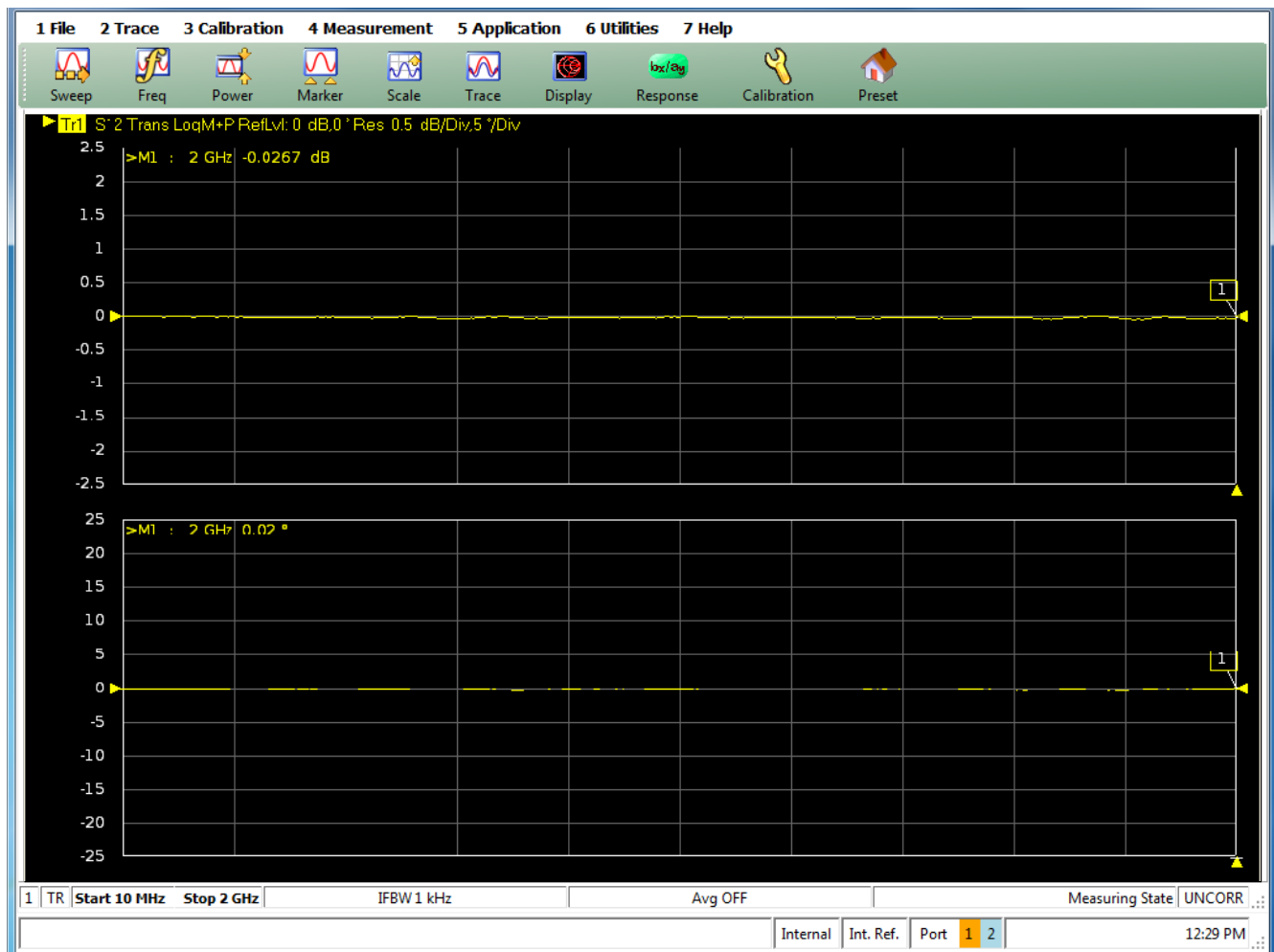


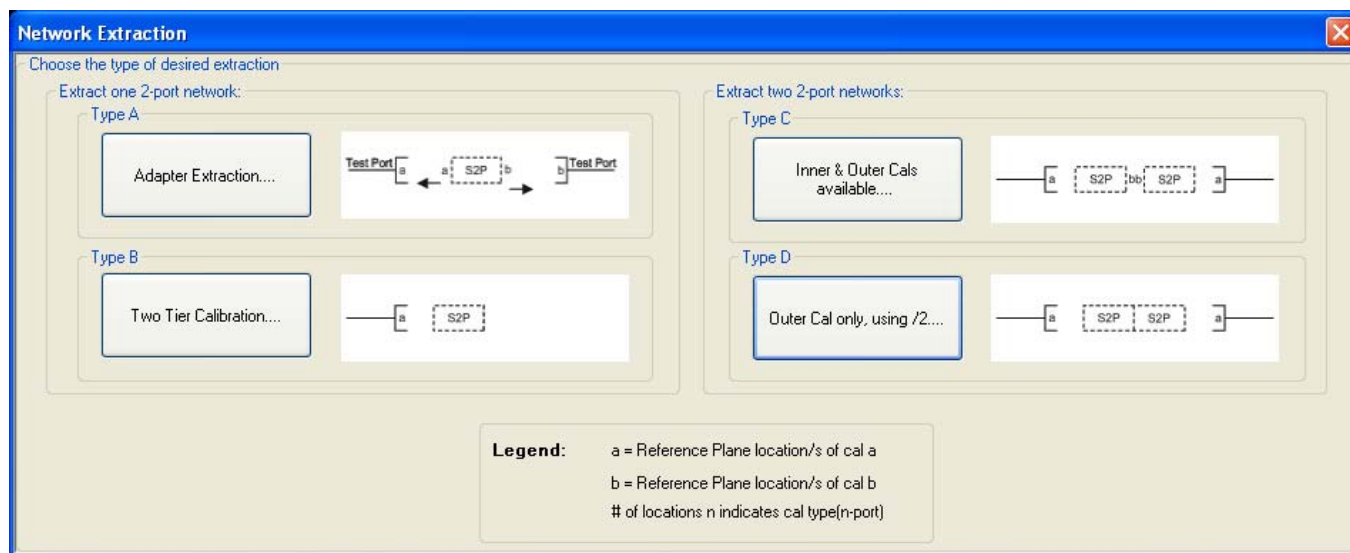
Figure 8-5. VNA Trace Display with Result of Adapter Removal

The through without the adapter was connected after executing the adapter removal utility and the near-perfect through values for  $S_{21}$  show that the algorithm successfully removed the adapter from the calibration. As expected, the thru without the adapter shows nearly zero insertion loss and phase shift, and a very good match. Any residuals are largely due to cable flex. Had this connection been made with one of the initial two calibrations applied,  $S_{21}$  would have shown about 3 dB of gain since the adapter had been built into each calibration.

## 8-4 Network Extraction

De-embedding is covered in detail in [Chapter 10, “Calibration and Measurement Enhancements”](#) but since the generation of files for some de-embedding exercises is so closely tied to adapter removal; it will be briefly discussed now. De-embedding is the removal of the effects of a network from a set of data. This network could represent an adapter or fixture among other things. To perform the de-embedding, the parameters of this network must be known. While there are many methods of deriving these parameters (including simulation), measurement in some way is often preferred. Because of the complex and incompatible media that may be involved, techniques using multiple calibrations (in different connectors or different media) or techniques using a pair of adapters/fixtures back-to-back are sometimes employed.

For the two port VNA, there are four types of extraction techniques available and are shown in the NETWORK EXTRACTION dialog box shown below in [Figure 8-6](#).



**Figure 8-6.** NETWORK EXTRACTION Dialog Box - 2-Port VNAs

### Type A - Two Full 2-Port Cals

Two full 2-Port calibrations are performed; one each with the adapter/fixture attached to one port then the other. A single S2P file describing the adapter/fixture is generated. This is directly the method of adapter removal except the parameter file is generated explicitly rather than the calibration being directly modified.

### Type B - Two Tier Two 1-Port Cals

A two tier calibration, some times called 1-Port de-embedding or the Bauer-Penfield technique. Here a one port cal is performed and then another one port cal is performed with the adapter/fixture in place. This is very similar to type A except a thru connect is not required and the far-end match is determined differently. A single S2P file is generated.

### Type C - Inner and Outer Cal

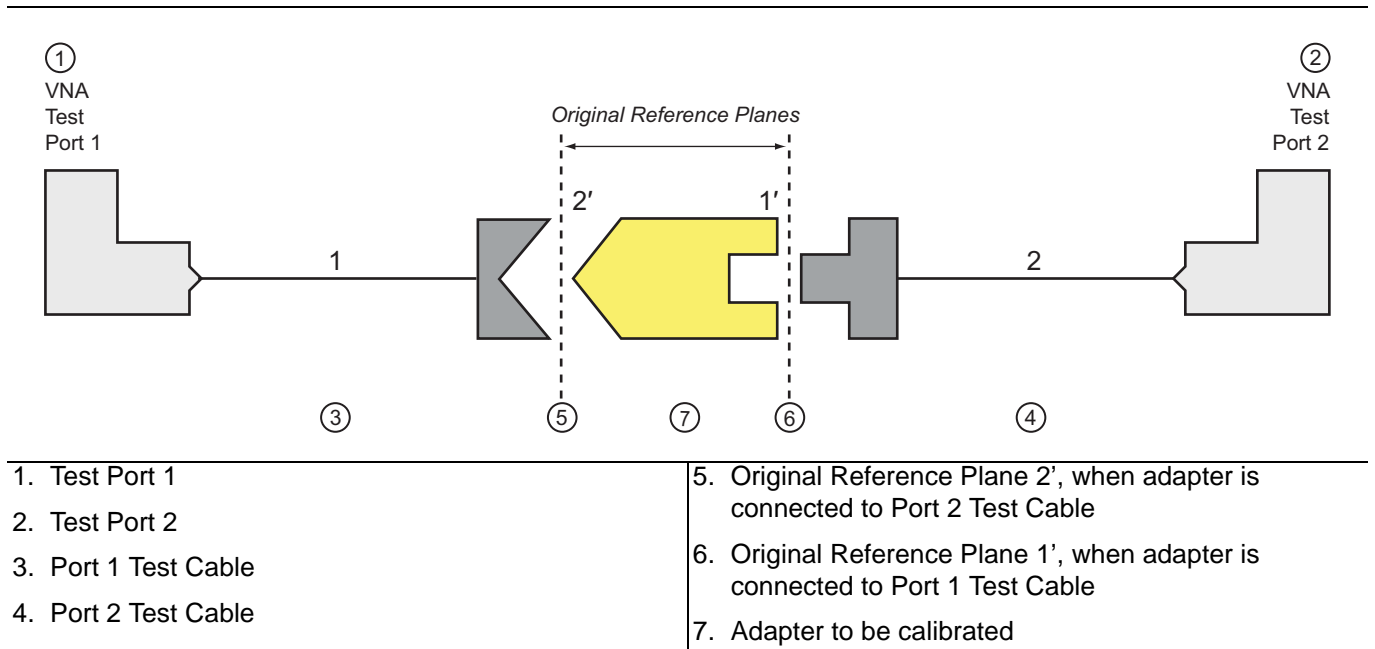
This is the network extraction method available in earlier generations of Anritsu VNAs where full 2 port calibrations are performed at the outer plane (often coaxial or waveguide) and at the inner plane (often a fixtured environment). Two S2P files are generated in this case.

### Type D - Outer Cals Using the Divide-By-Two Method

This simplified method is used when standards at the inner plane are difficult to create (as in a complicated fixture structure). Two adapter/fixture “halves” are connected back-to-back and the combination measured using a single outer cal. Assuming the interconnect between the two halves is well-matched and the two halves are identical, S-parameters can be extracted. The match at the inner plane is assumed good (since no other information is available) so this technique is best used when the overall adapter/fixture return loss is quite high. Two S2P files are generated.

## 8-5 Network Extraction: Type A

As discussed above, the type A extraction uses exactly the same procedure and algorithm as adapter removal. Instead of directly modifying the calibration to remove the effects of the adapter/fixture, however, the S-parameters of the adapter/fixture are exported to an S2P file for later de-embedding or other uses. The reference plane diagram is repeated below for convenience. Two full 2-Port calibrations are required, one with the adapter on **Port 1** (so the cal is between 1' and 2) and one with the adapted on **Port 2** (so the cal is between 1 and 2').



**Figure 8-7.** Adapter Removal Block Diagram

The calibrations are performed and then the setups saved typically as an active channel CHX file type. The extraction dialog is shown below where these files are retrieved to perform the process. After “Perform Extraction” is selected, a new dialog will appear asking for the file name where the S2P data should be saved.

As with adapter removal, a few caveats apply

- The two calibration files must have the same frequency lists (i.e., same frequency range and same number of points).
- The cal algorithms and media types may be different but they must both be full 2-Port cals
- The adapter is assumed to be reciprocal ( $S_{12} = S_{21}$ ).

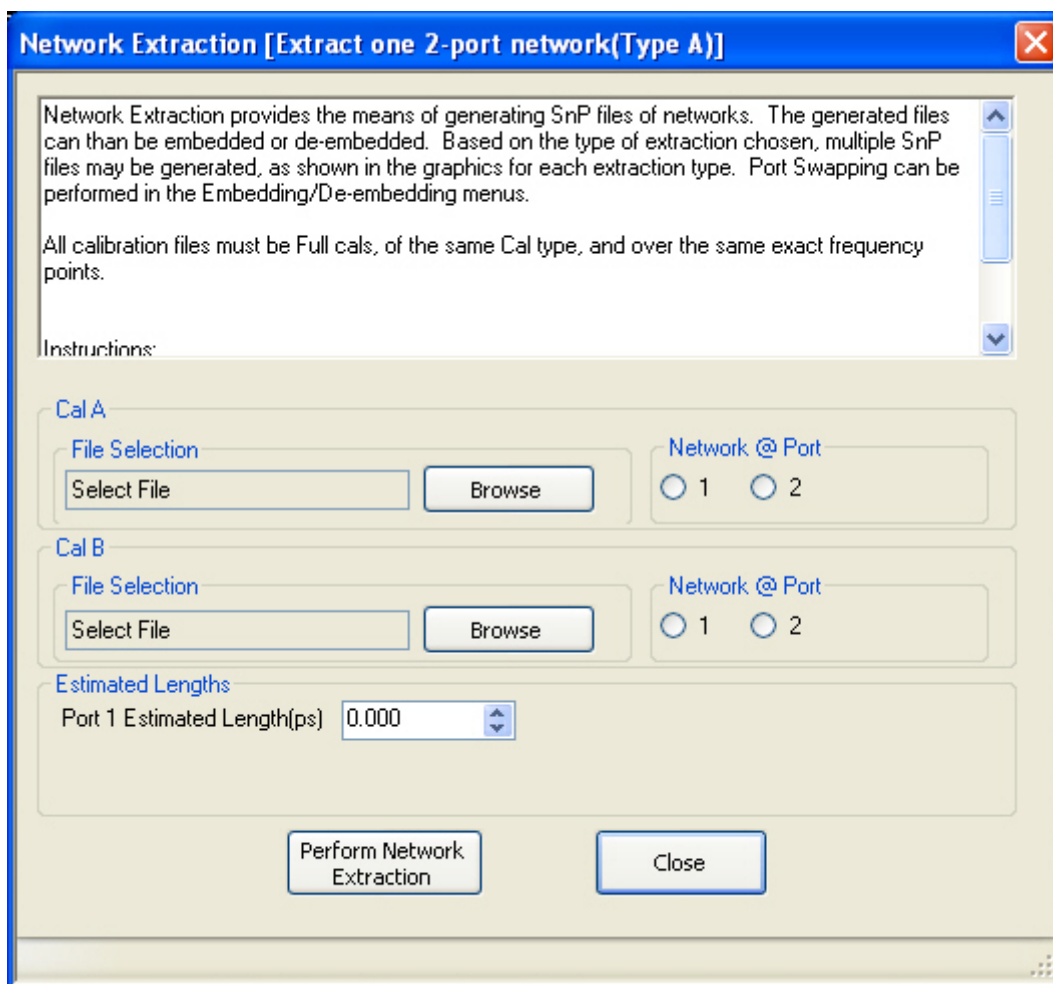
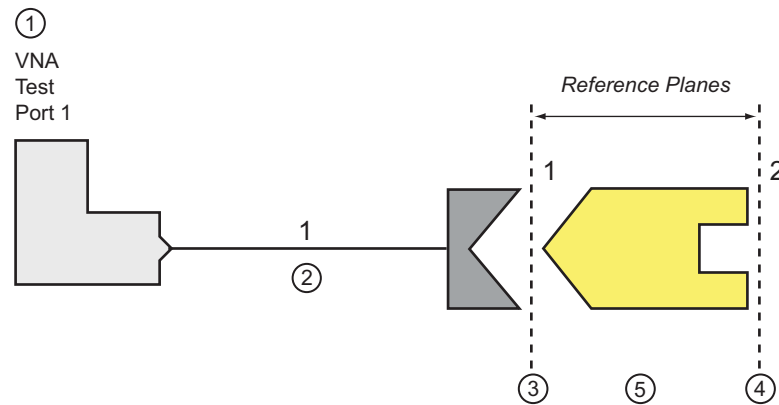


Figure 8-8. NETWORK EXTRACTION Dialog Box - Extract One 2-Port Network - Type A - 2-Port VNAs

## 8-6 Network Extraction: Type B

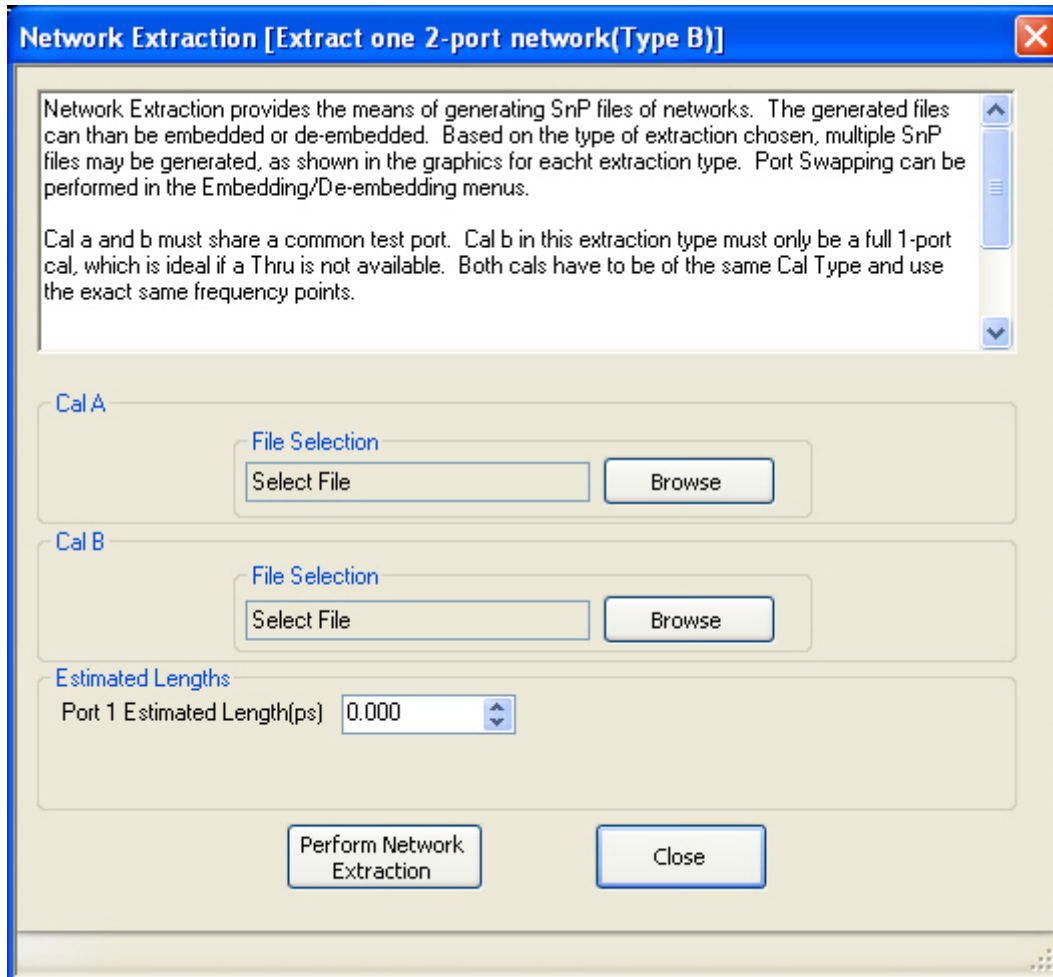
The Type B extraction is a simplification of Type A in that it only requires a pair of one port cal. This can be useful if a thru connect is difficult because of adapter/fixture configuration issues. This particular algorithm has a long history and is covered in the literature extensively (for example, *R. Bauer and P. Penfield, "De-embedding and unterminating," IEEE Trans. Micr. Theory Tech., vol. 22, pp.282-288, Mar. 1974.*). As suggested by the figure below, a cal is performed at Plane 1 (often a coaxial or waveguide cal) and a second cal is performed at Plane 2 (could also be coaxial or waveguide in the case of an adapter or could be more complicated in the case of a fixture).



1. Test Port 1	4. Second Reference Plane at end of Adapter DUT
2. Port 1 Test Cable	5. Adapter DUT
3. Original Reference Plane for Port 1	

**Figure 8-9.** Network Extraction Type B Reference Planes

As before, the cals are performed and the setups saved, typically as an active channel CHX file type. The cal files are retrieved using the dialog below.



**Figure 8-10.** NETWORK EXTRACTION Dialog Box - Extract One 2-Port Network - Type B

After Perform Network Extraction is selected, another dialog appears asking for the file name where the resulting S2P data should be saved. Different cal algorithms and media types may be selected but at least Cal B must be 1-Port only. Cal A can be a full two port cal or a double 1-Port cal (this way it is known how to compute the extraction). As with Type A, the adapter/fixture is assumed to be reciprocal and the frequency lists must be the same.

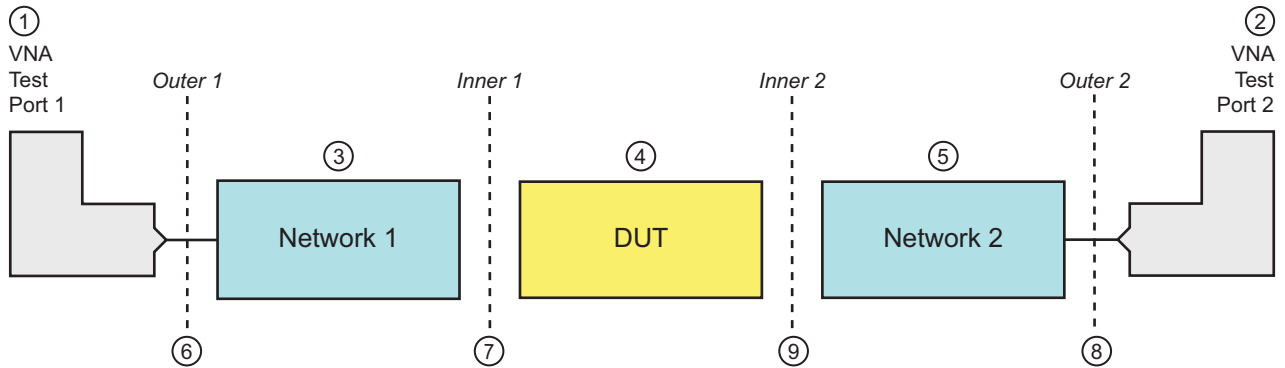
The results obtained with Type B may be somewhat different from those obtained with Type A since the algorithms are not the same. The main differences will be with respect to outboard match (at Plane 2 in [Figure 8-9](#) above). In Type A, this match is determined with a full reflectometer solve while in Type B, it is determined with a source-match like extraction on the error X of the second cal. As a result, the Type B extraction of this match will be somewhat more sensitive to cal quality than will Type A (particularly with regard to the source match-determining cal components: O and S in OSL or the two shorts in SSL). The trade-off is simplicity and, in some cases, practicality.



### 8-7 Network Extraction: Type C

Type C is the most complete, dual fixture extraction approach offered in the VNA. It requires full 2-Port calibrations at two sets of reference planes but can fully determine the S-parameters of two networks independently.

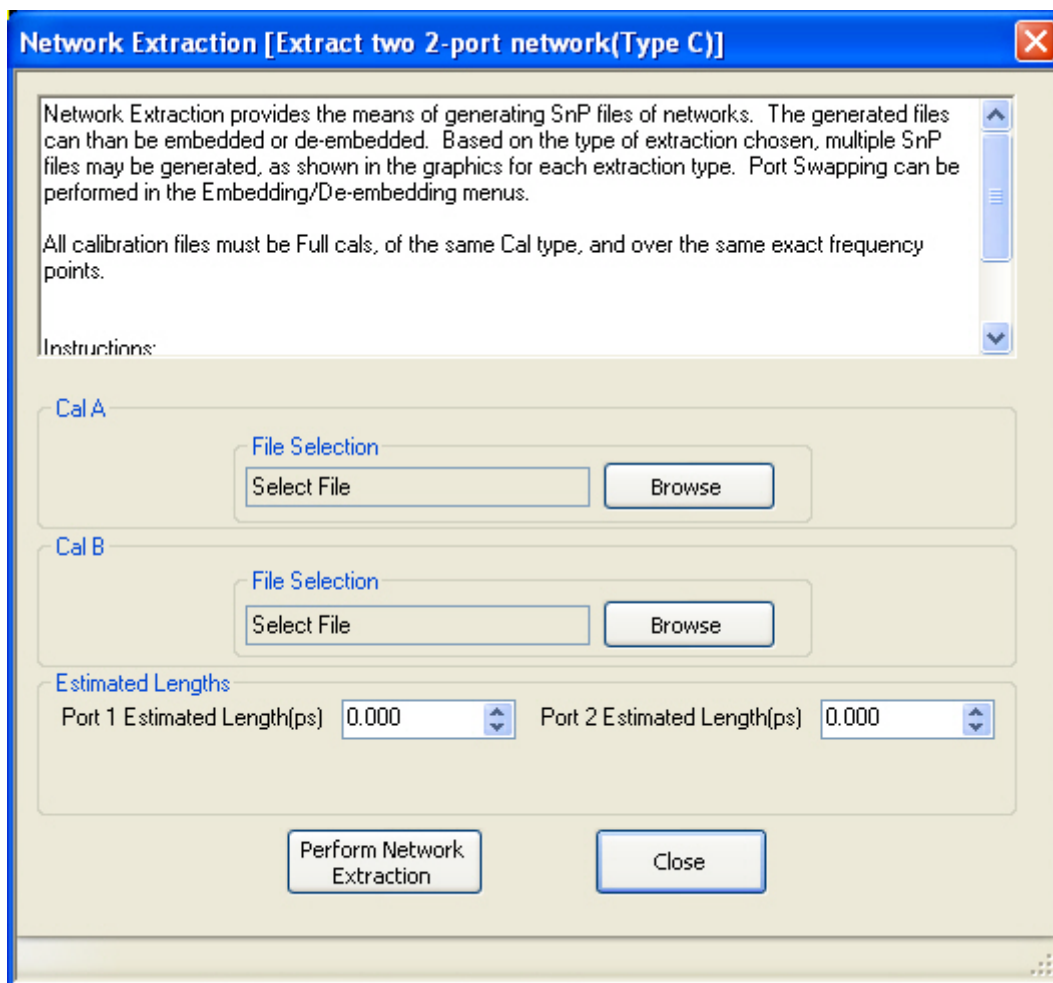
Consider the diagram in NETWORK EXTRACTION dialog box (above in Figure 8-6). A calibration is required at the outer reference plane set and the inner reference plane set. The outer calibration can usually be done coaxially (or some other well-defined media) depending on the networks involved. The inner calibration is often more complicated and may be board- or wafer-level (and may require the user create calibration standards). Assuming these calibrations are possible, then the S-parameters of Network 1 and Network 2 can be found.



1. Test Port 1	5. Network 2 attached to Test Port 2
2. Test Port 2	6. Outer Reference Plane 1
3. Network 1 attached to Test Port 1	7. Inner Reference Plane 1
4. DUT attached to Network 1 (on left) and Network 2 (on right)	8. Outer Reference Plane 2
	9. Inner Reference Plane 2

Figure 8-11. Network Extraction Process Diagram for Type C Networks

Two port calibrations at two different reference plane sets are used to extract the S-parameters of the intervening networks (often test fixtures). The dialog for loading the two calibrations is shown in NETWORK EXTRACTION [Extract Two 2-Port Networks (Type C)] dialog box below.



**Figure 8-12.** NETWORK EXTRACTION Dialog Box - Extract Two 2-Port Networks - Type C

As before, the two calibrations are performed and the setups saved, typically as an active channel CHX file type.

Some conditions:

- The two calibrations must be full 2-Port cals and must have the same frequency lists.
- After extraction is performed, a file dialog will appear allowing the user to indicate where the S2P files should be stored.
- The networks are assumed to be reciprocal.

Unlike Types A and B, this method determines the two fixture halves completely and independently. As a trade-off, a complete set of standards at the inner plane are now required. Algorithmically, this type is very similar to Type A except two networks are processed simultaneously. If the inner cal standards can be successfully made/acquired, the inner match values extracted will typically be more stable than those acquired with a Type B analysis for the reasons discussed in the previous section.

### 8-8 Network Extraction: Type D

Type D is considerably different from the other techniques in that it relies only on a single back-to-back measurement to extract parameters rather than relying on the manipulation of a pair of calibrations. A full 2-Port calibration is performed at the outer planes and two adapter/fixture “halves” are connected back-to-back as suggested in Figure 8-13 below. This simple technique is appropriate when it is just not practical to create standards at the inner plane (other than a thru connection effectively) and some estimate of the insertion loss of the fixture is needed. The technique does a minimal job of match extraction and allocates all mismatch to the outer plane of the adapter/fixture half (since no other information is available,  $S_{22} = 0$ ). The technique is not recommended (unless there is no other option) if the adapter/fixture return loss is very poor. With a 20 dB RL, there will be generally 0.3 dB or more of insertion loss uncertainty with this technique (as opposed to  $\leq 0.1$  dB with other techniques if good standards are available). With a 10 dB RL, it will be several dB of uncertainty. As with the other techniques, reciprocity is assumed.

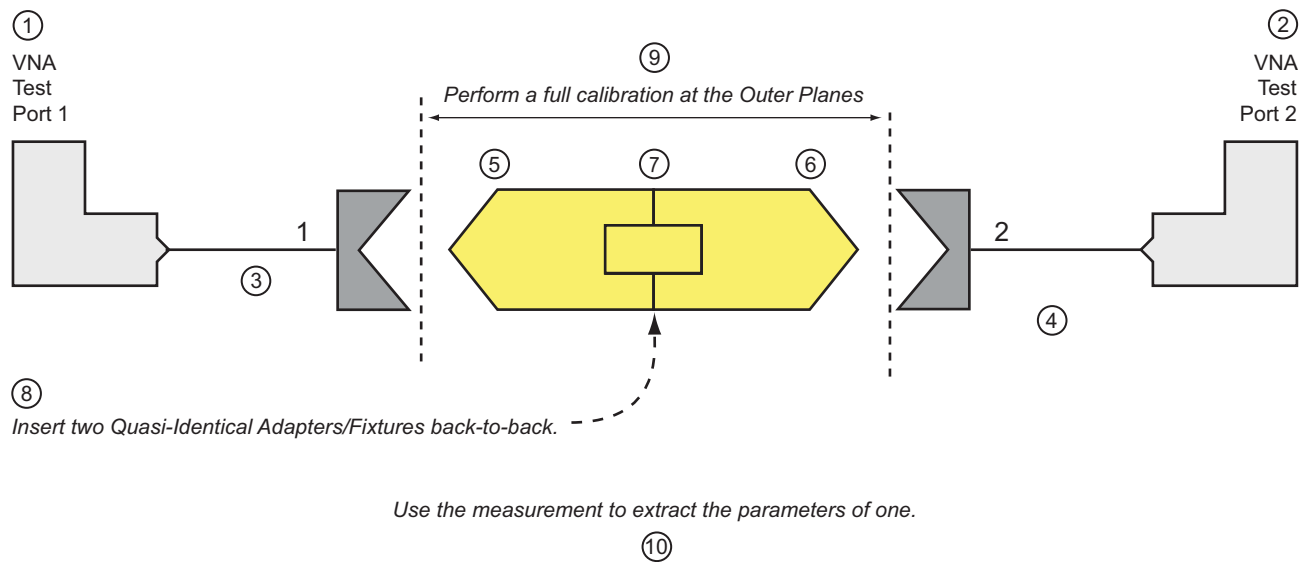


Figure 8-13. Network Extraction Type D Inner and Outer Planes

The dialog is a very simple one and is shown below. The outer calibration should be active when this procedure is called since files are not recalled as with the other techniques. Because it is sometimes difficult to allocate or interpret the match terms, a check box is provided to ignore those terms altogether. In this case,  $S_{11} = S_{22} = 0$  (linear) in the exported S2P file. As with the other techniques, a dialog will appear upon execution to allowing the naming of the destination S2P file.

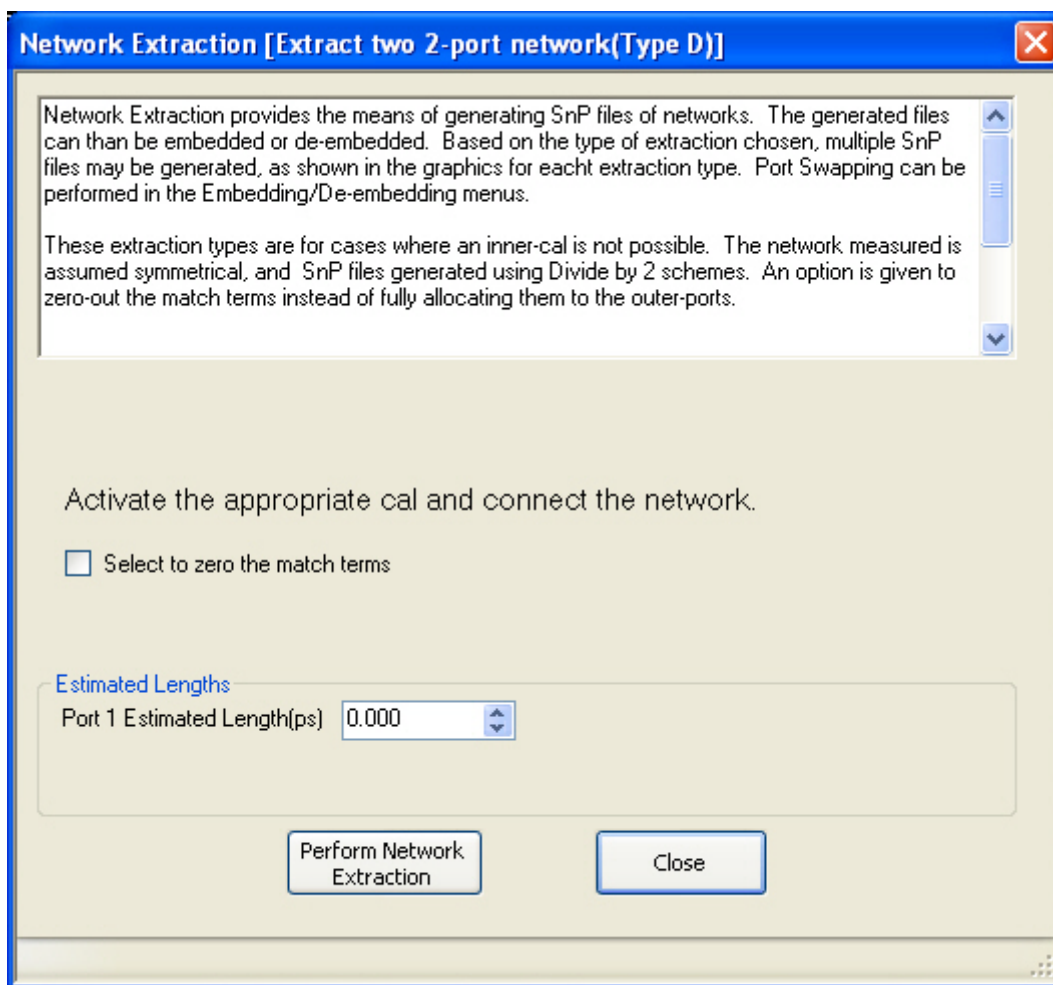


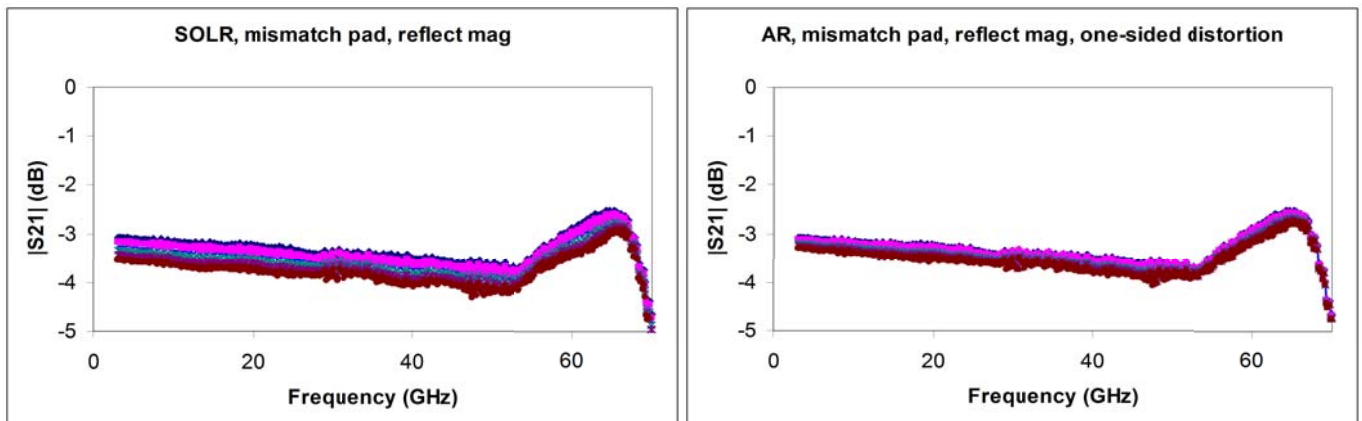
Figure 8-14. NETWORK EXTRACTION Dialog Box - Extract Two 2-Port Networks - Type D

## 8-9 Uncertainty and Sensitivity

The selection of a network extraction method is heavily dependent on the standards that are available at the inner plane and the results can vary wildly depending on the quality of and knowledge about those standards. While we cannot be complete in this guide in a discussion on uncertainties and sensitivities, we can give some general thoughts. Many publications exist on the topic that may provide more information, such as *J. Martens, "Common adapter/fixture extraction techniques: sensitivities to calibration anomalies, 74th ARFTG Conf. Dig., Dec. 2009*, and references therein.

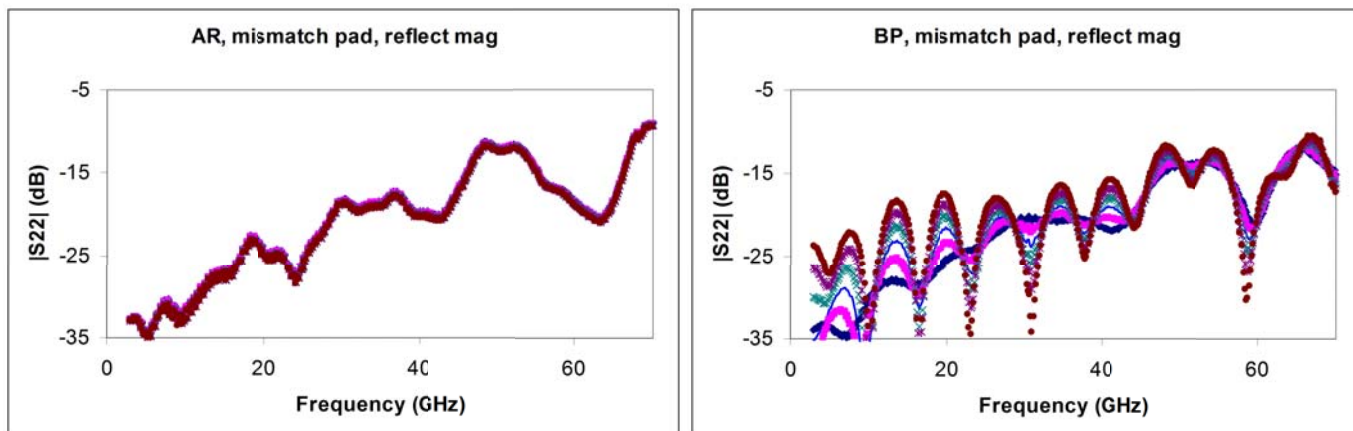
The type C extraction is, in some sense, the most complete since it uses all of the error terms in two full-port calibrations to extract the S-parameters of the individual fixture arms. For that reason, type C is also the most sensitive to standards quality at the inner plane. Uncertainties will follow those of the underlying calibrations quite closely, subject to a repeatability penalty associated with the two calibrations.

Type A is a bit different in that there is only one fixture arm, but it does still use two full-term calibrations. The computation difference is that it does not use transmission or load match terms to calculate the adapter/fixture S-parameters and hence is more immune to problems with those calibration steps than is type C. Even if there is a problem with a reflect standard, type A may be less sensitive since the reflect errors propagate to load match in the standard calibrations (particularly true for reciprocal methods as is discussed in [Chapter 15](#)). As an example, a mismatched pad was evaluated using both type A extraction and an SOLR calibration, but a perturbation was introduced in one of the reflect calibration standards. As shown in [Figure 8-15](#), the sensitivity with type A (labeled AR for adapter removal) is lower. The comment 'one-sided-distortion' is included in the plot since symmetric errors in a type A setup tend to cancel (another advantage in some cases), so the introduced error was made on only one side in this measurement to create a worst-case result. Each trace in the plots represents a different assumed reflect magnitude value for the standard (over a 10 % interval).



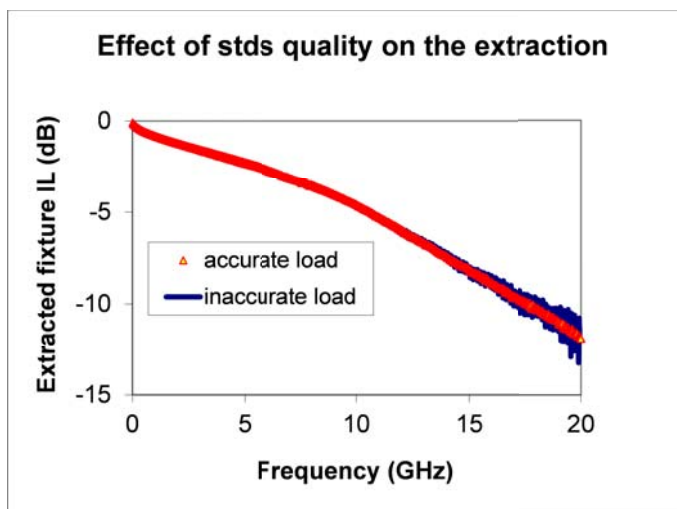
**Figure 8-15.** A comparison of the effects of a reflect standard problem on both a type A extraction (AR) and a SOLR calibration.

Although less sensitive to some effects, it may not always be possible to do reasonable full port calibrations to support type A. The type B method requires only one port standards, which can be far more convenient. The internal computations are similar between type A and type B except in how output match is determined. Type B is a more source match-intensive computation, so there is greater sensitivity to the high reflect standards' behavior with type B than with type A (and less dependence on low reflect behavior). A comparison is shown in Figure 8-16 for type A (again labeled AR for adapter removal) and type B (labeled BP for Bauer-Penfield, two of the original authors to work on this method class). The sensitivity of output match to a reflect standard problem (a short in this case) is indeed greater. Again, each trace represents a different reflect magnitude value.



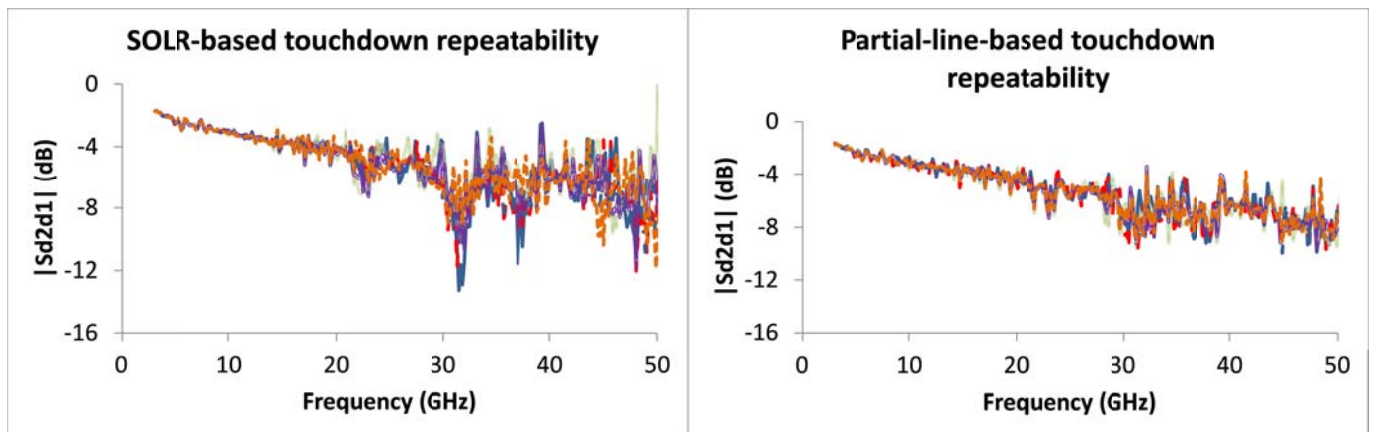
**Figure 8-16.** A comparison of output match sensitivity for type A (AR) and type B (BP) methods.

Correspondingly, the load sensitivity is somewhat reduced, but it will have an impact on high RL adapters and high IL adapters, as suggested in Figure 8-17.



**Figure 8-17.** The effect of a load standard problem on extracted insertion loss with type B. Eventually, the load accuracy does matter.

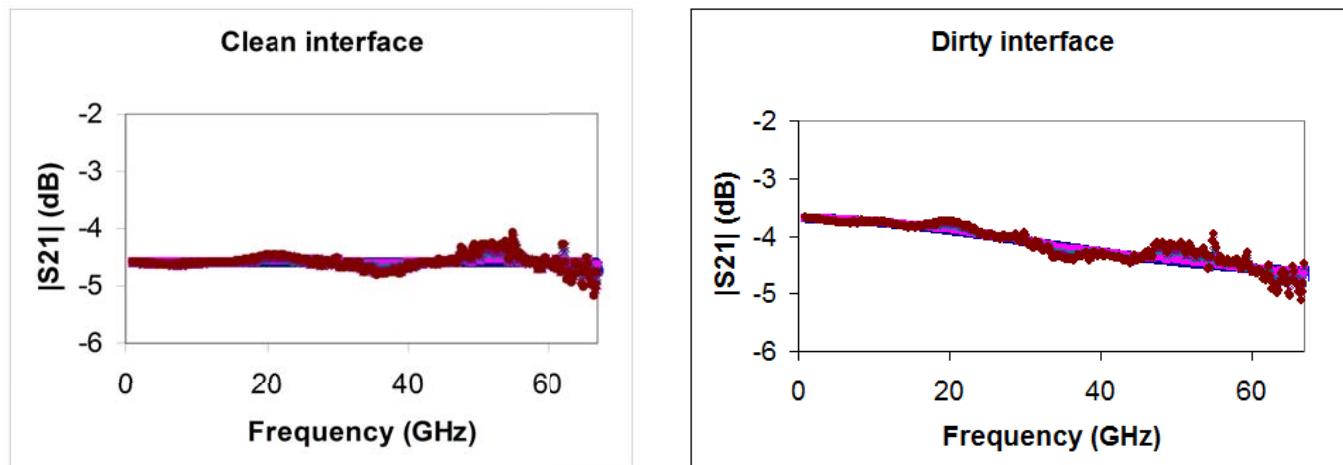
Type D is another approach entirely and is appropriate when it is difficult to create any reasonable standards at the inner interface. Also, when repeatability is problematic (for example, spring contacts, poorly positioned probes, etc.) trying to achieve knowledge of fewer parameters can be useful. The concept is to give up on assessing the inner plane match and just concentrate on getting a decent estimate of insertion loss. The absolute accuracy will be degraded from what one could get from either of the other methods (if good standards were available), but repeatability sensitivity can be greatly improved and the net practical uncertainty can actually be better. This follows from the  $1/(1-x)$  kind of behavior of match terms in the standard methods. If the measurements are not terribly repeatable and the 'x' term is moving near unity, the uncertainty on the final parameter in practical terms can balloon. One can see this in a wafer probing example where probe placement was not that accurate. A series of calibrations were done using SOLR and using type D extraction (labeled partial information in [Figure 8-18](#)). The removal of match dependence lowered the scatter in the final insertion loss values.



**Figure 8-18.** A comparison of repeatability effects is shown here for two methods (standard calibration and type D) when that repeatability was not good.

While repeatability sensitivity is better, there is sensitivity to inner plane match and to problems with the underlying calibration at the outer planes (although reduced).

The effect of an inner plane distortion is shown in [Figure 8-19](#). The effects can be substantial, but the errors in this particular example would have exceeded 4 dB with a type C methodology because the media was pin-based and not repeatable.



**Figure 8-19.** The sensitivities of a type D extraction to underlying calibration issues (multiple traces per plot, reflect magnitude variations) and introduction of an inner plane match and position problem (the dirty interface plot).

The various extraction methods discussed here present a variety of choices dependent on standards quality, the media involved, and the possible measurement repeatability. In some sense it is a continuum (C->A->B->D) of choices more appropriate as the environment becomes decreasingly metrology-friendly. This is an oversimplification, but some of the sensitivities presented may help in making a good choice for a given measurement setup.

## 8-10 Summary

Adapter removal is a 2-calibration technique for removing the effects of an adapter from a given calibration setup (e.g., when the DUT has one coax port and one different port, such as a waveguide port).



# Chapter 9 — Other Calibration Procedures

## 9-1 Overview of Other Calibration Procedures

This chapter covers the Thru Update and Interpolation calibration procedures.

## 9-2 Through (Thru) Update

The Thru Update is a one-step calibration that can be used to refresh a current full 2-Port or 1 path-2 port calibration by connecting a through line to quickly refresh the transmission tracking and load match terms.

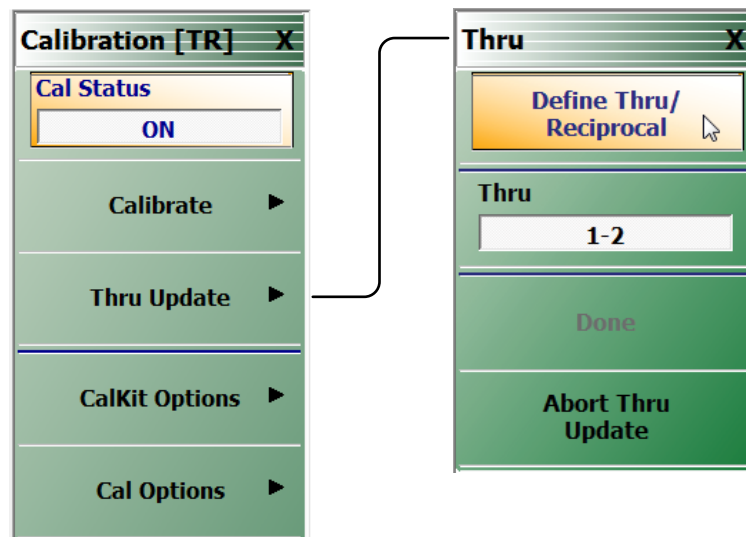


Figure 9-1. THRU UPDATE Setup Menu

Like the thru step in other calibrations, the length of the line being used as well as its loss can be specified to ensure minimal disruption of the reference planes (see Figure 9-2). The entry methods for these parameters are the same as in the normal calibration procedures.

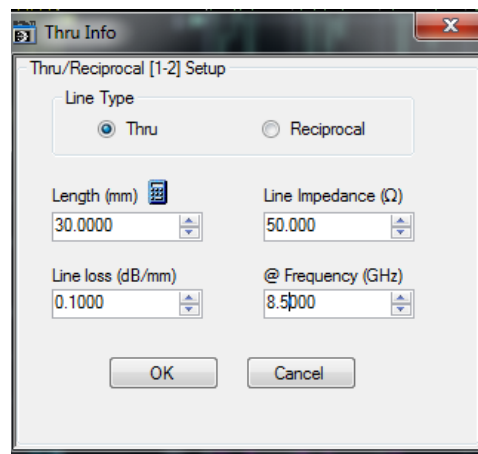
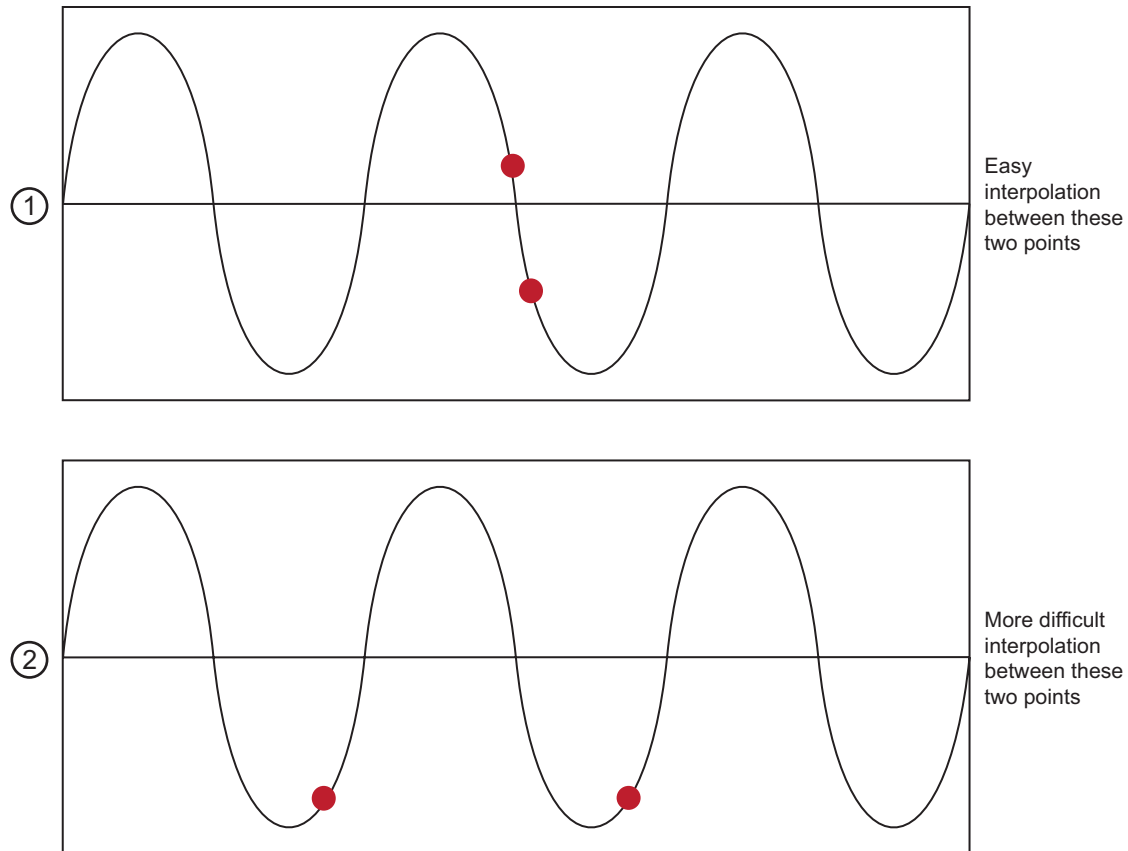


Figure 9-2. Thru Dialog

## 9-3 Interpolation

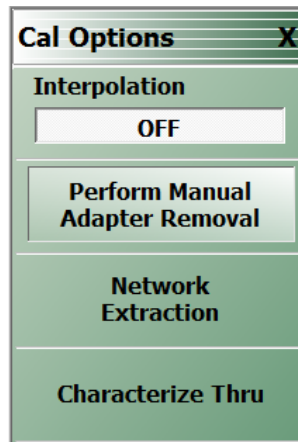
Typically, calibration is done for a specific list of frequencies and then measurements are made over that same list of frequencies. While this is most accurate, it is not necessarily convenient. If, for example, one is measuring a variety of narrow bandpass filters of different center frequencies, it may be useful to be able to zoom in to look at the passband of each filter without re-calibrating. Interpolated calibrations are allowed for purposes like this one. The theory is that the error coefficients are all carefully interpolated between calibration points to minimize possible error.

To see the cause of error, note that the cable runs within the instrument and the cables that the user provides typically result in a large electrical length. Thus the error coefficient magnitude versus frequency is often periodic in shape. If the interpolation is not performed with care, large errors can result (see [Figure 9-3](#)).



**Figure 9-3.** Effect of Step Size on Interpolation

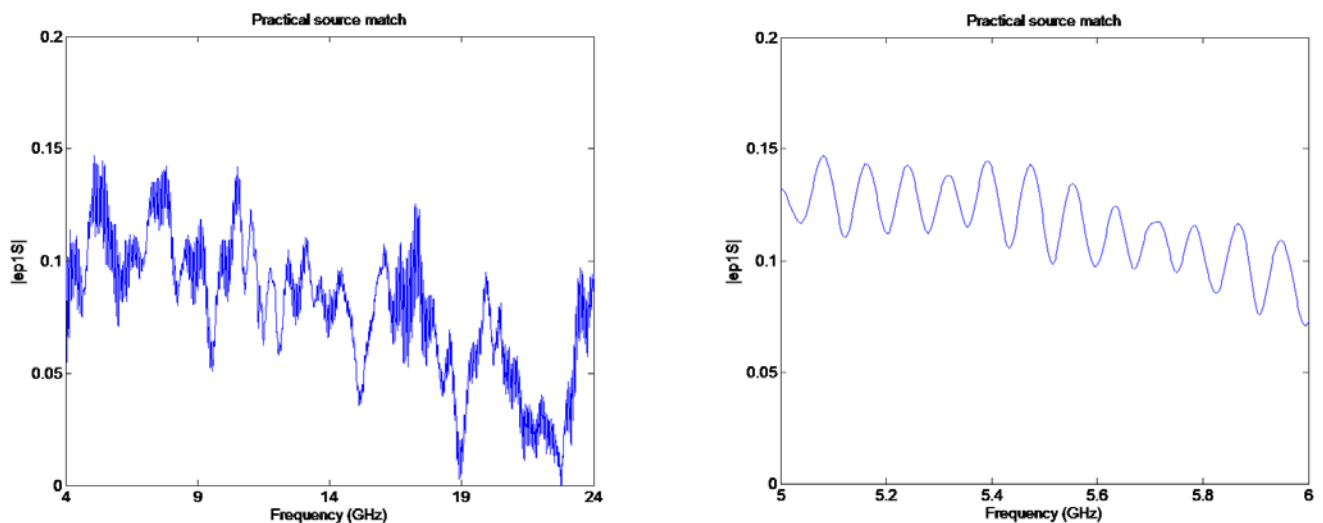
As a general rule, the smaller the step size used during the calibration, the more successful the interpolation will be. It is desirable to keep the step size smaller than the ripple period of the coefficients which will typically range from 50 MHz to 500 MHz. The smaller number is for setups with very long test port cables and fully optioned systems. The menu to select interpolation is shown below in [Figure 9-4](#).



**Figure 9-4.** CAL OPTIONS Menu

The calibration interpolation menu will default to OFF where points used during measurement must correspond to calibration frequency points. When interpolation is ON, other points may be used. In neither case may frequencies outside of the calibration frequency range be used.

To gain a better understanding of the uncertainty implications of interpolation, it may be helpful to consider how the error terms of a typical calibration vary over frequency. A large scale and zoomed-in version of one parameter (source match) is shown in [Figure 9-5](#). Even with relatively low point densities, the large scale variation in the large-scale plot would be captured by interpolation. The fine scale variation shown in the zoomed-in plot is, however, another matter.

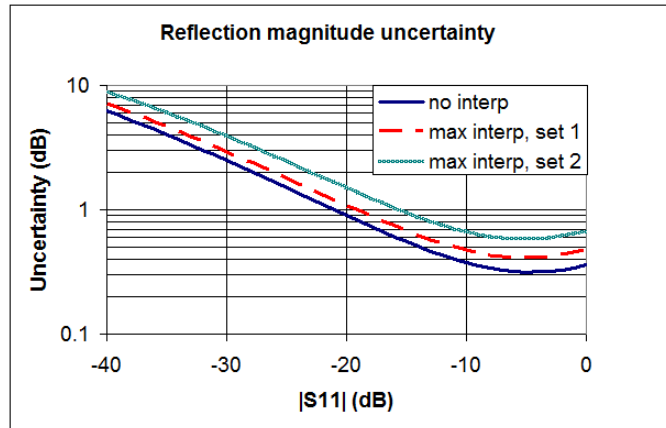


**Figure 9-5.** Large scale and zoomed-in source match variation over frequency.

Now, consider two different sets of hardware, both with a nominal tracking coefficient of unity (for simplicity). At lower frequencies, set 1 may be readily achieved, but at mm-wave frequencies, set 2 may be more practical. The important point is that the interpolation effects are setup-dependent.

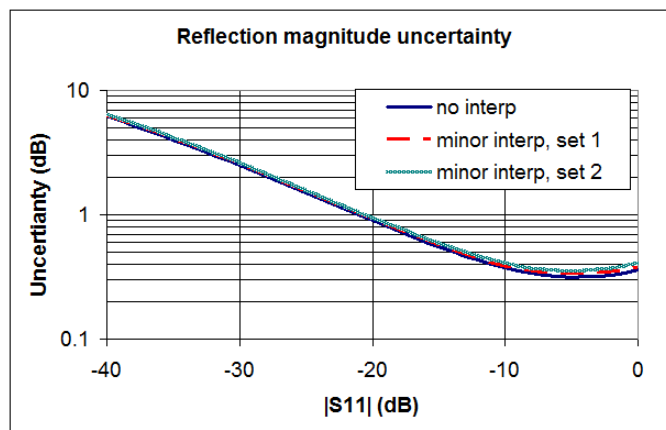
- Set 1: Raw directivity  $\sim 0.02$  (-34 dB) and raw source match  $\sim 0.1$  (-20 dB)
- Set 2: Raw directivity  $\sim 0.10$  (-20 dB) and raw source match  $\sim 0.3$  (-10 dB)

If one calculated the uncertainties for no interpolation and for worst-case interpolation for both of these sets, one would get results like that shown in [Figure 9-6](#) (for a standard SOLT coaxial calibration).



**Figure 9-6.** The uncertainty penalties possible with worst-case interpolation are shown here for some example setups.

As suggested above, one can get around this problem by increasing the frequency point density. In [Figure 9-7](#), the point count was increased so that there were 10 calibration points per period of the ripple (a proxy for the electrical length of the setup, much like that discussed in [Chapter 10, "Calibration and Measurement Enhancements"](#)).



**Figure 9-7.** An increase in frequency point density can reduce interpolation effects in all setups as would be expected.

# Chapter 10 — Calibration and Measurement Enhancements

## 10-1 Chapter Overview

This chapter provides a description of functions that provide additional calibration, post-processing, and display options that increase the usefulness of the instrument data.

These functions go beyond the basic calibration and display tools to help post-process the data in a way that is useful. The topics described relate to virtually modifying the environment in which the DUT resides.

These topics include:

- **Embedding/De-embedding**

This is the virtual removal or insertion of networks or circuits around a DUT that may represent fixtures, launching structures, tuning elements, or other items. This feature is accessed from the Measurement menu.

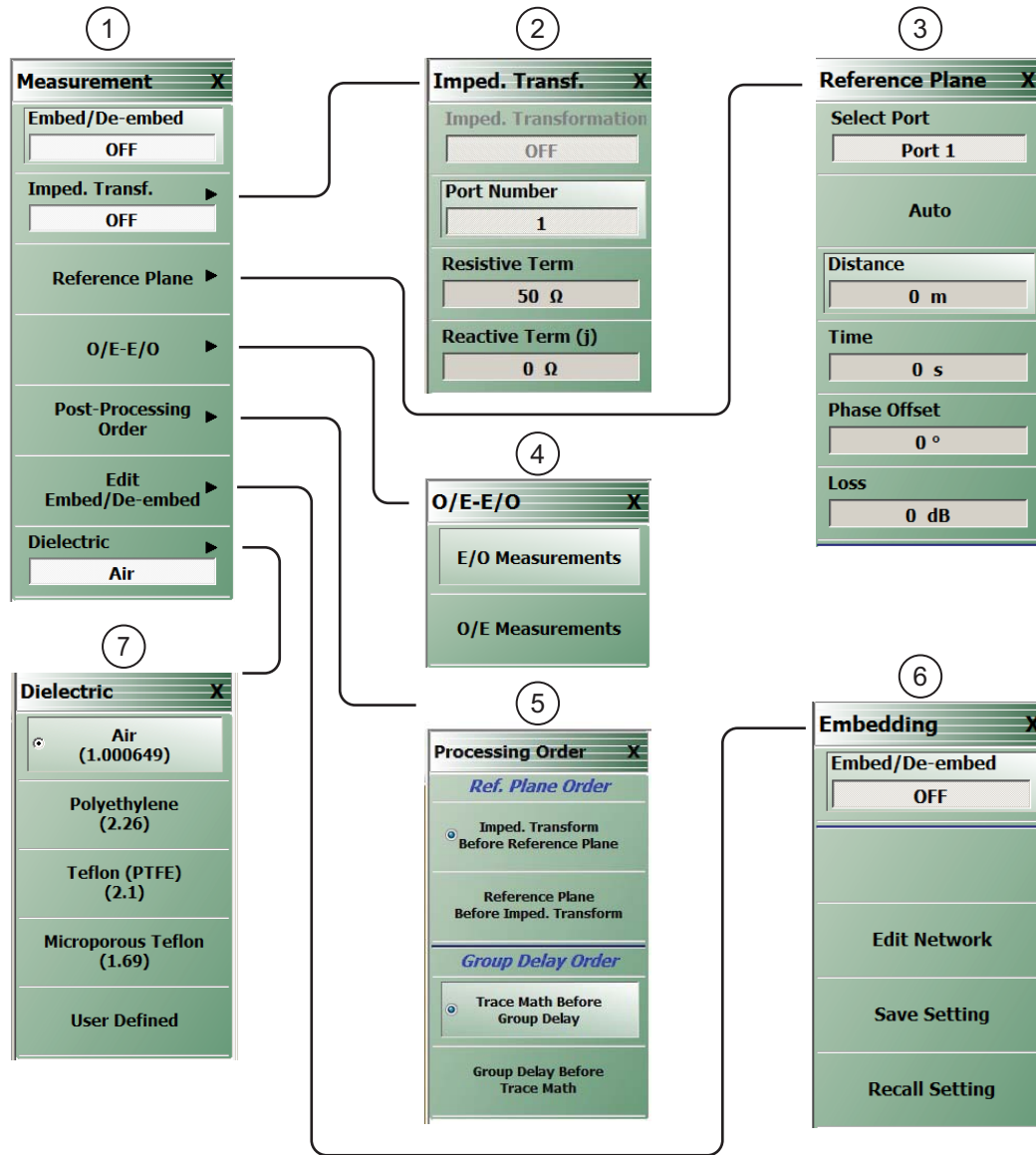
- **Reference Plane Control**

This can be thought of as a simpler subset of de-embedding in which transmission line lengths and loss are removed from the measured data. This feature is accessed from the Measurement menu.

- **Conversions**

While S-parameters (or the un-ratioed wave parameters) are usually the display variables of interest, conversions to other parameters may be required and are possible with the Shockline™. This feature is accessed from the Display menu.

In addition, there are some clerical tasks to describe including the order of virtual operations and some conversions to other parameter formats (impedances and admittances for example). The measurements menu that contains the majority of these functions is shown below ([Figure 10-10, “REFERENCE PLANE Control Menu” on page 10-12](#)). Parameter conversions are a per-trace function (as opposed to the others which are per channel) and is listed under the DISPLAY menu.



- |  |   |
|--|---|
| 1. MEASUREMENT Menu                              | 4. PROCESSING ORDER Menu  |
| 2. IMPED. TRANSF.(Impedance Transformation) Menu | 5. EMBEDDING Menu   |
| 3. REFERENCE PLANE Adjustment Menu               | 6. DIELECTRIC Selection Menu – If User Defined is selected, Value field is available for input. |

Figure 10-1. MEASUREMENT Menus

## 10-2 Embedding/De-embedding (E/DE)

The MS4652xB Series VNAs are equipped with an embedding/de-embedding system. De-embedding is generally used for removal of test fixture contributions, modeled networks, and other networks described by S-parameters (s2p files) from measurements. Similarly, the embedding function can be used to simulate matching circuits for optimizing amplifier designs or simply adding effects of a known structure to a measurement. Multiple networks can be embedded/de-embedded (E/DE) and changing the port and network orientations is handled easily. An extraction utility is part of this package that allows the easier computation of de-embedding files based on some additional calibration steps and measurements.

It is extremely valuable to be able to virtually remove or add networks to the measured data as described above. The process of adding network data to measured data is termed “embedding” while the process of removing network data is termed “de-embedding.”

### Embedding Tasks

Common embedding tasks are to:

- View results as if a different launch structure was present
- View results as if a new matching circuit was being used
- View results as if an added cable length or transmission line length was needed

### De-Embedding Tasks

Common de-embedding tasks are to:

- Remove the effects of a test fixture
- Remove the effects of a launch or launching transmission line
- Remove the effects of a test matching circuit that will later be physically removed

The VNA embedding/de-embedding engine (E/DE) is a flexible tool for performing tasks of this type. A number of different circuit element primitives are available and full S2P files can also be loaded.

**Note**

Circuit parameters for embedding-de-embedding network elements are stored in S2P files that can be loaded into the Shockline™.

## Embedding On/Off Control

E/DE can be turned on and off with the Embed/De-embed toggle button at the top of the main MEASUREMENT menu as shown above (Figure 10-1) or with a duplicate toggle button at the top of the EMBEDDING control menu as shown below (Figure 10-2).

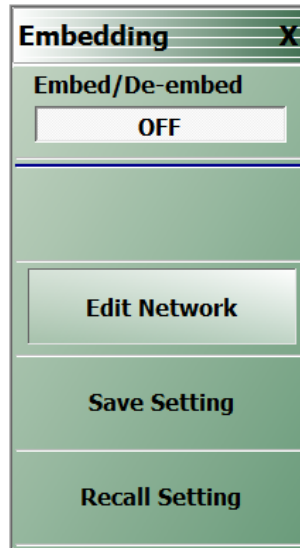
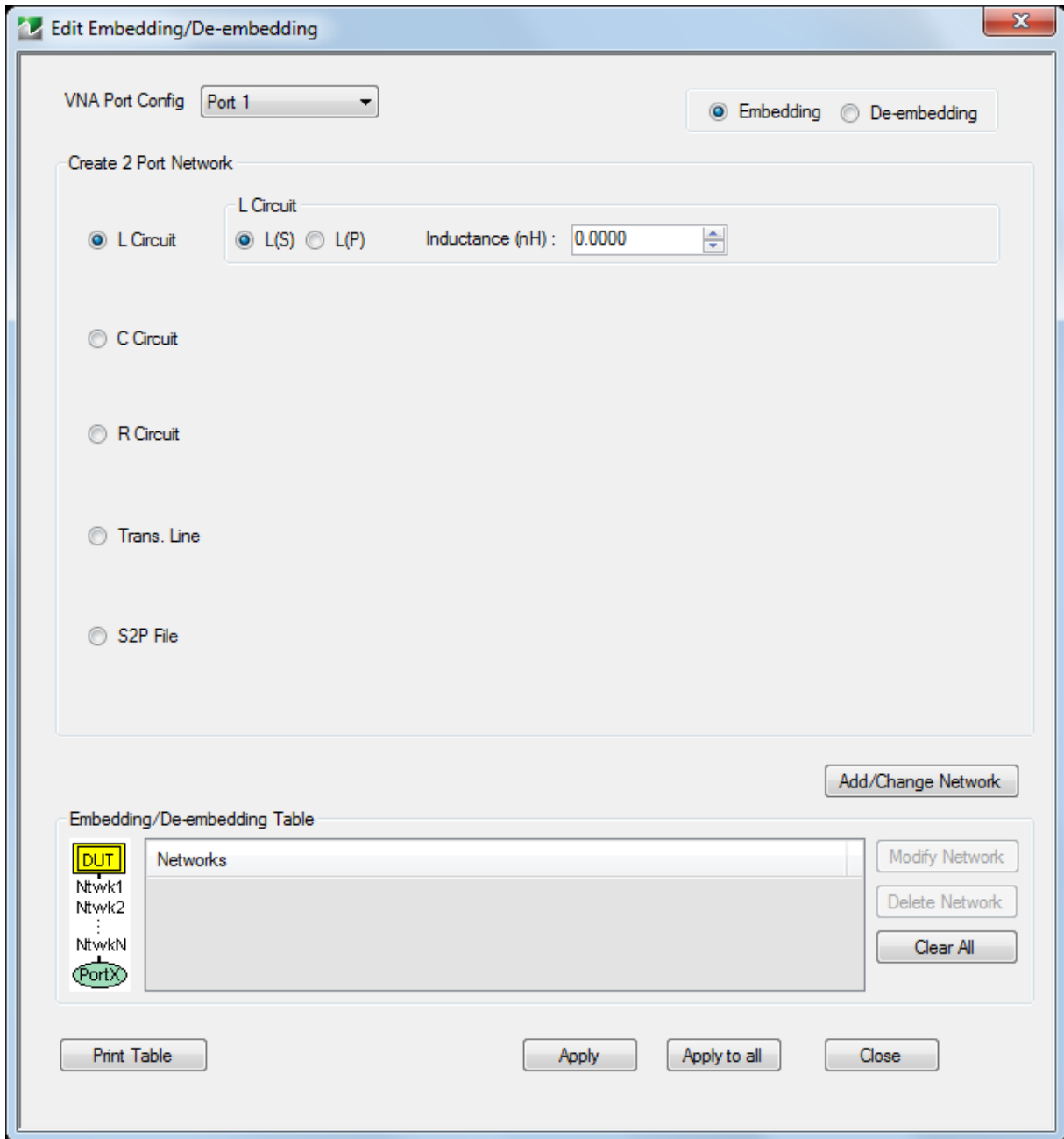


Figure 10-2. EMBEDDING Menu



Clicking on Edit Network displays the main EDIT EMBEDDING/DE-EMBEDDING dialog box. An example with Embedding, L Circuit, and L(S) selected, but with no network information entered is shown in the figure below.



L Circuit - L(S) - Embedding Selected

**Figure 10-3.** EDIT EMBEDDING/DE-EMBEDDING (2 PORT DUT) Dialog Box - L Circuit

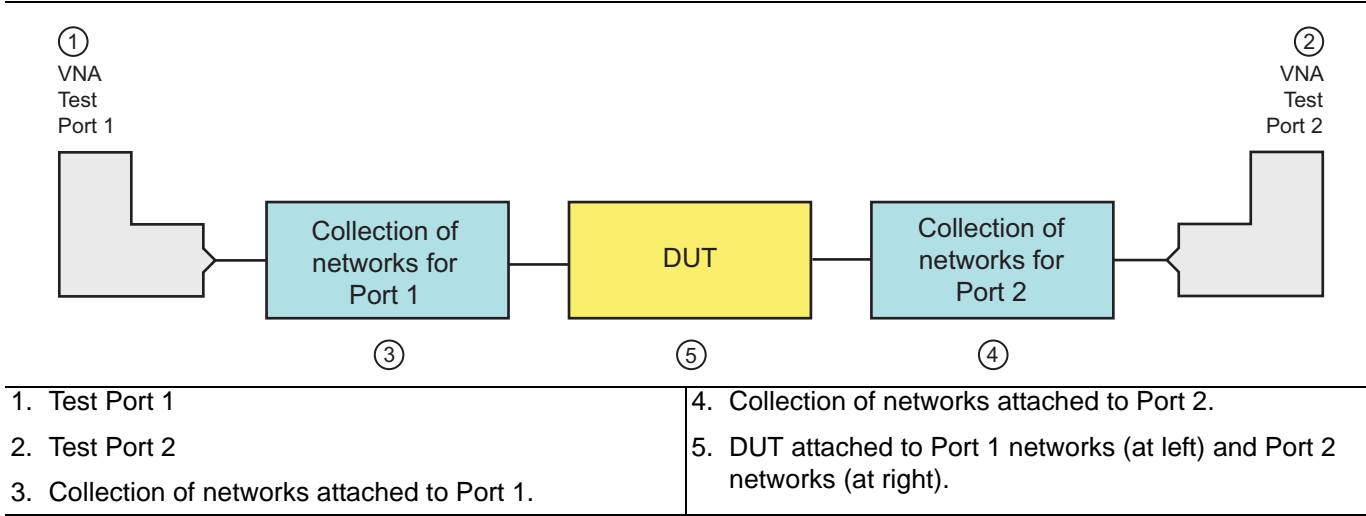
**Note**

Embedding and de-embedding is setup for each port and the networks used on the two ports are entirely independent. Also, any number of networks can be cascaded at a given port and the first network entered is always nearest the DUT.

The key concepts for embedding and de-embedding are:

- Networks are setup on a per-port basis
- The networks used on the two ports are entirely independent
- Any number of networks can be cascaded at a given port

The first network entered is always nearest the DUT. The pull-down menu at the top of Figure 10-3 shows which port's networks are currently being edited. The diagram in Figure 10-4 illustrates the independence concept.



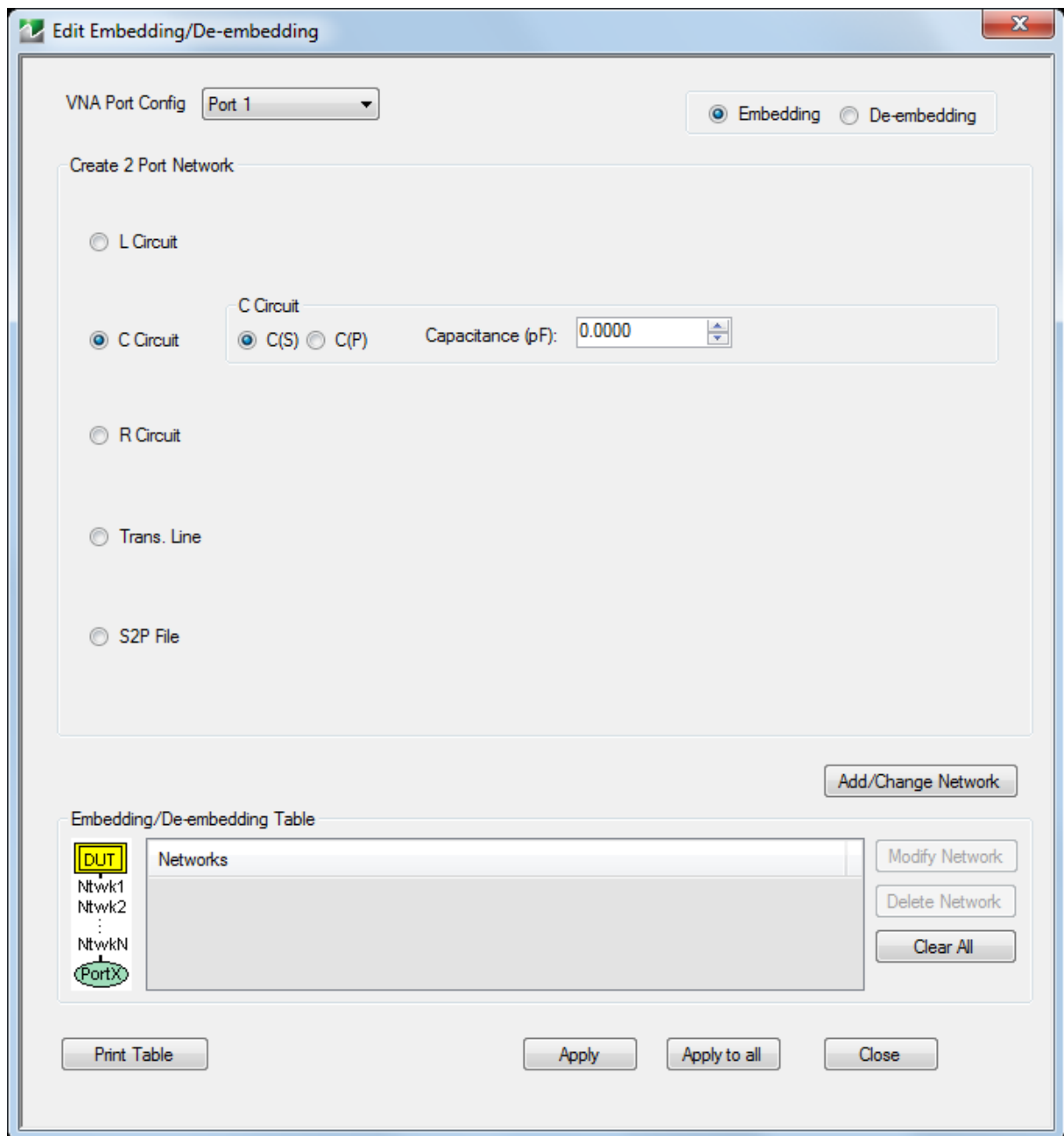
**Figure 10-4.** Global EDE Diagram Showing Independence of Port Networks

## Types of E/DE Networks

There are five types of networks that can be entered:

- Inductive elements
- Capacitive elements
- Resistive elements
- Transmission lines
- .S2P-defined, file-based networks

In the Edit Embedding/De-embedding dialog box in [Figure 10-3](#) above, the radio button for entering an LC network has been selected. An additional version of the dialog box is shown in the figure below where a C(S) network has been selected.



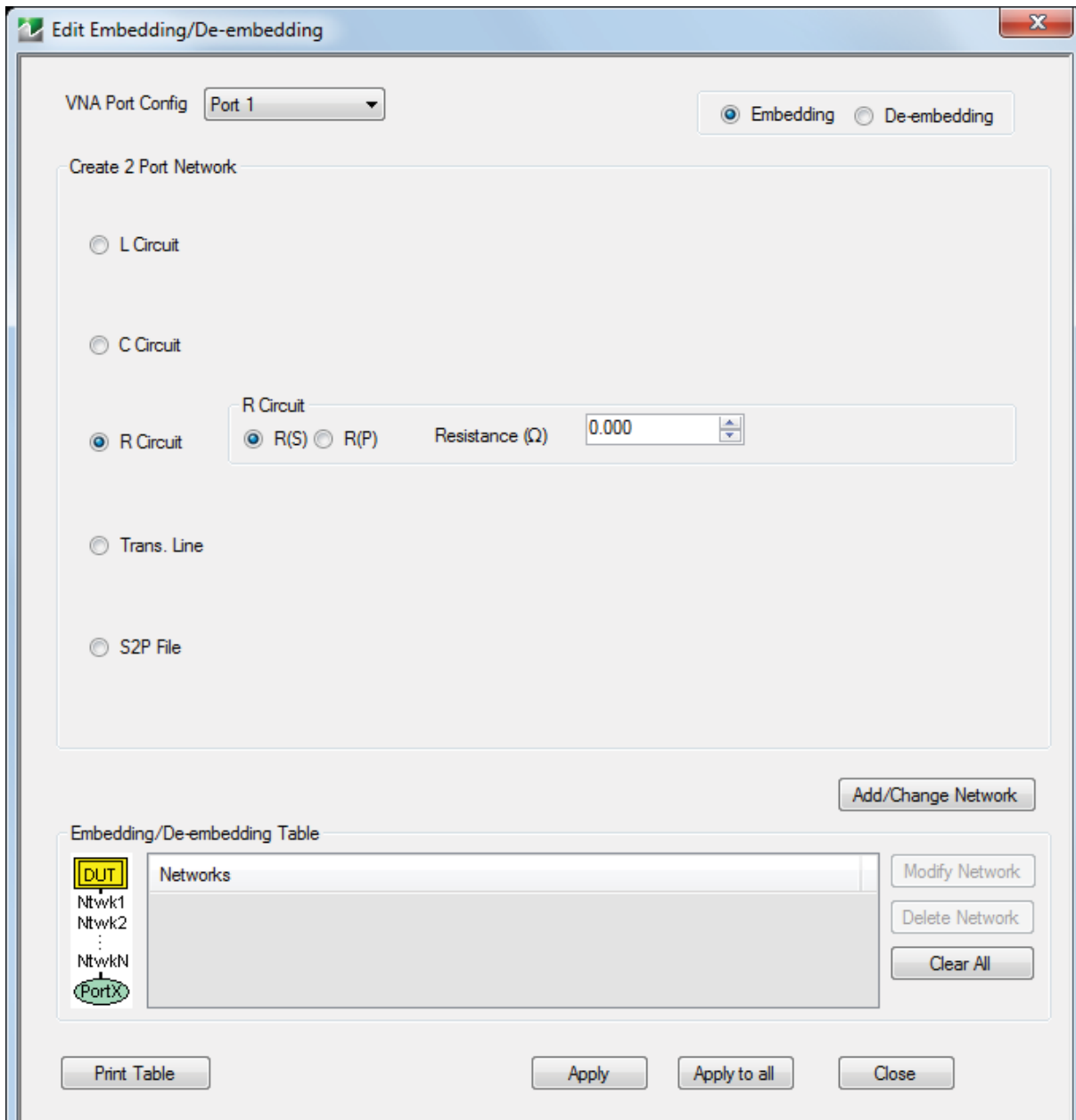
**Figure 10-5.** EDIT EMBEDDING/DE-EMBEDDING - C Circuit

## Entry Mode for Resistive Elements

The entry mode for these resistive elements is shown in the E/DE dialog box below (Figure 10-6). Both series (denoted by an (S)) and shunt (to ground) elements (denoted by a (P) for parallel) are allowed and selectable with the radio buttons. Since this element is symmetric, no orientation knowledge (with respect to DUT port and VNA port) is needed. The default units are:

- Inductance: nH
- Capacitance: pF
- Resistance: ohms

It should be emphasized that the shunt or (P) elements are always shunting to ground (not to the other port). If cross-port elements are desired, then the multiport version of the instrument should be used with an appropriate calibration.



Resistive Element Entry

**Figure 10-6.** EDIT EMBEDDING/DE-EMBEDDING Dialog Box - R Circuit Setup Selected

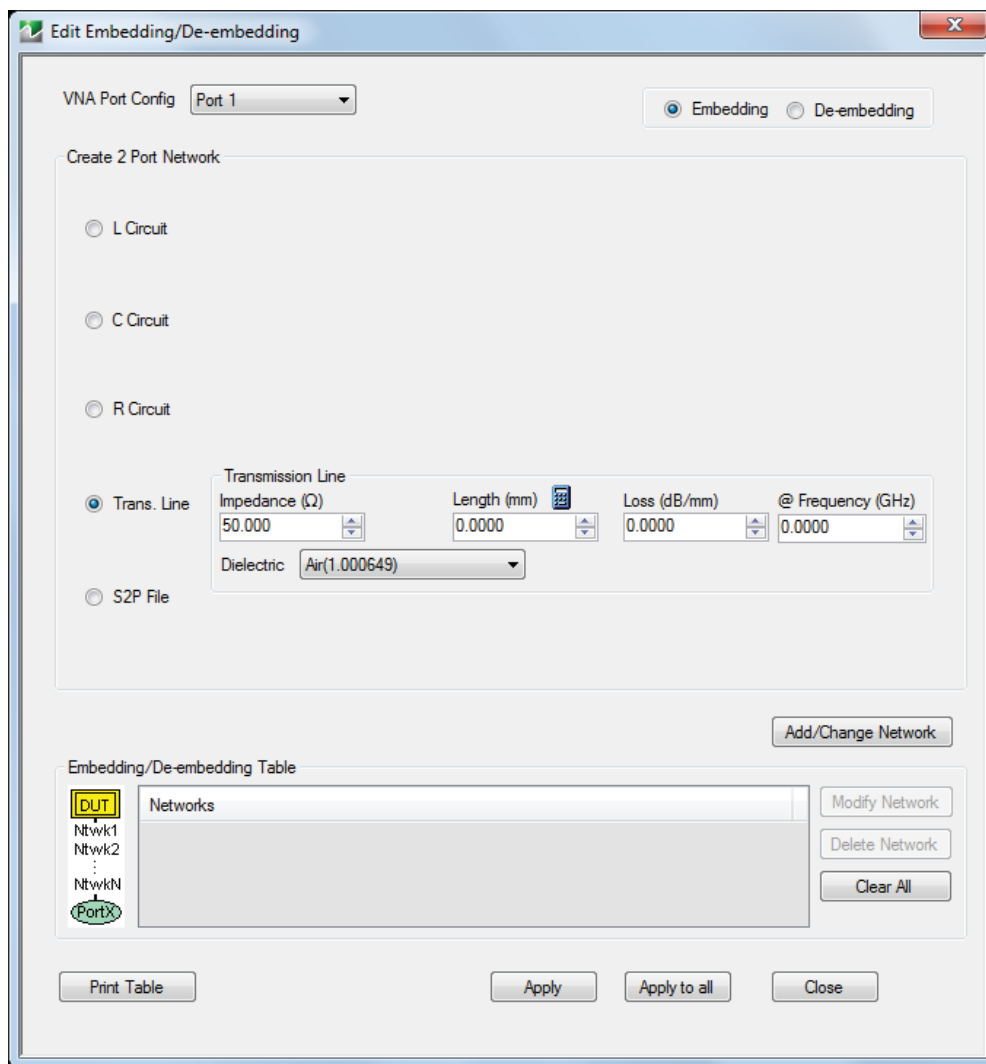
## Entry Mode for Transmission Lines

Transmission line entry is illustrated in the E/DE dialog box below (Figure 10-7). As with transmission line entry in other parts of the system, loss can be entered along with a reference frequency. The loss at other frequencies will be computed using:

$$\text{Loss}(f) = \text{Loss}(f_0) \times \sqrt{\frac{f}{f_0}}$$

Eq. 10-1

As elsewhere in the system, if a 0 (zero) frequency reference is entered, the loss value entered will be used as a constant at all frequencies.



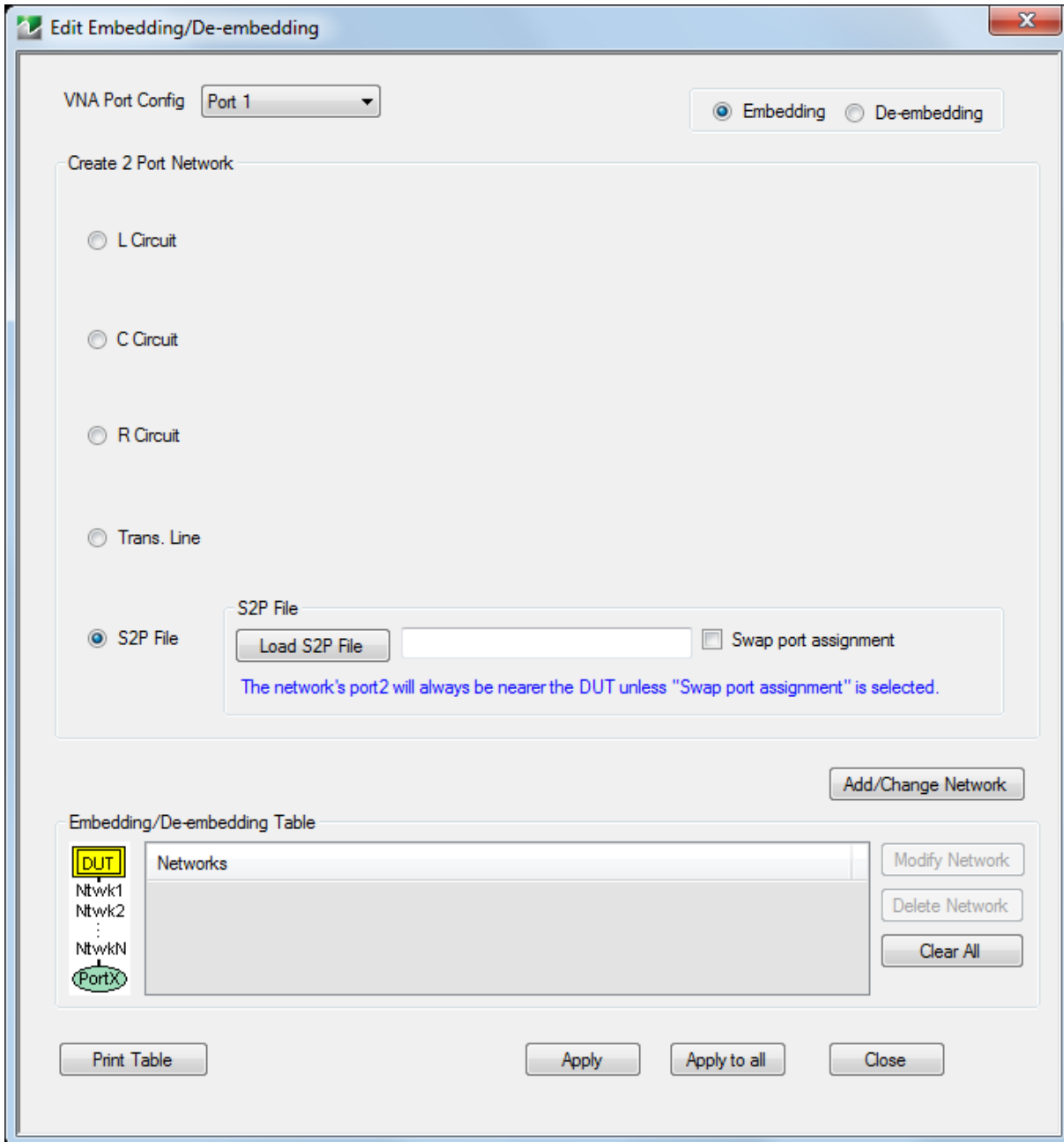
T-Line Selected - Transmission Line Element

**Figure 10-7.** EDIT EMBEDDING/DE-EMBEDDING Dialog Box

Physical line length is normally entered here along with a dielectric constant but the calculator icon shown in above in Figure 10-7 can be used (which links to the AIR EQUIVALENT LENGTH CALCULATOR dialog box) if only a time delay is known. Again, since this element is symmetric, no orientation knowledge is needed.

## Entry Mode for S2P Defined File-Based Networks

Finally, direct file entry of network S-parameters is shown in the E/DE below (Figure 10-8). A standard S2P file format is assumed and the headers will be interpreted. The system will attempt to interpolate the provided data the best it can in the context of the current channel sweep range. If there is no overlap between the sweep range and the file frequency range, an error will be generated.

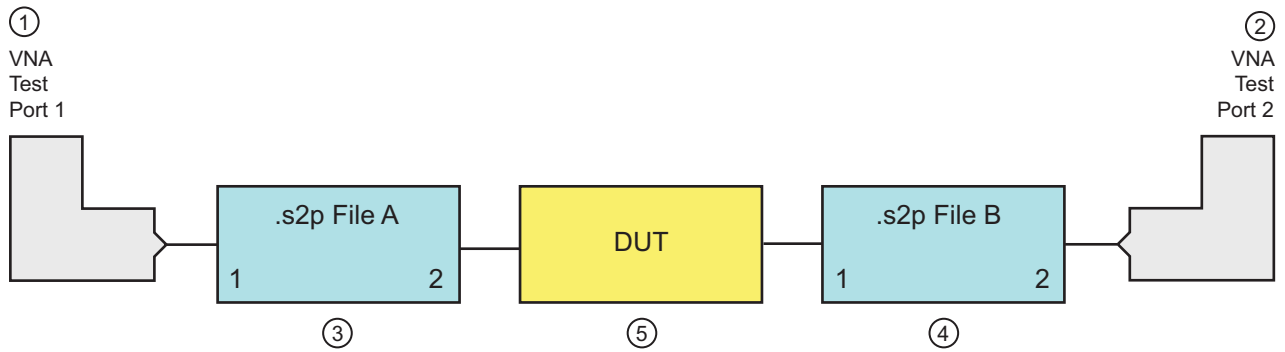


S2P File - File-Based Element Entry

**Figure 10-8.** EDIT EMBEDDING/DE-EMBEDDING Dialog Box

**Note**

Note that the network Port 2 is always assumed to be closer to the DUT regardless of which VNA port is involved, as shown in Figure 10-9 on page 10-11. If “Swap port assignment” is checked, the relationship is reversed.



- |   |   |
|---|---|
| 1. Test Port 1                                    | 4. .s2p File B – Port 1 to left, Port 2 to right. |
| 2. Test Port 2                                    | 5. DUT  |
| 3. .s2p File A – Port 1 to left, Port 2 to right. |   |

Figure 10-9. Orientation of Loaded S2P Files

### Saving and Recalling Embedding Network Configuration

Once a set of networks (consisting of one or more individual networks) is defined, the E/DE configuration information can be saved to a file using the **Save Setting** button on the **EMBEDDING** menu (Figure 10-2, “**EMBEDDING Menu**” on page 10-4). Similarly, a stored E/DE setup can be recalled by using the **Recall Setting** button on the **EMBEDDING** menu.

The current E/DE setting is also saved as part of the master setup save (under the menu bar **FILE** menu) but multiple embedding and de-embedding circuits can be saved in these menus as well.

## 10-3 Reference Plane Control

A simplified means of performing de-embedding (and embedding in some contexts) can be accomplished using reference plane control. The function of this control is to remove transmission line lengths from the data. By entering a time or distance, this length of line will be removed (negative lengths are allowed to effectively add length). Various dielectrics and the full dispersion choices (see calibration section of the Measurement Guide for more information) are available as shown in the REFERENCE PLANE control menu below (Figure 10-10). The ports are handled independently, as in E/DE, and the current port being affected is indicated by the toggle at the top of the menu.

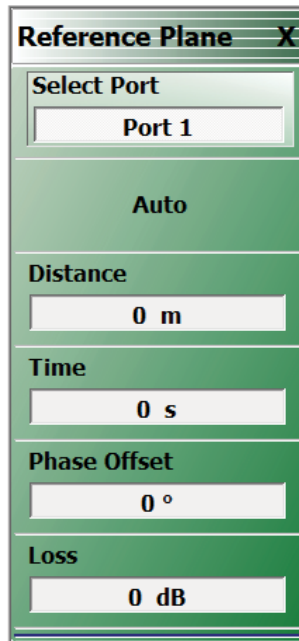
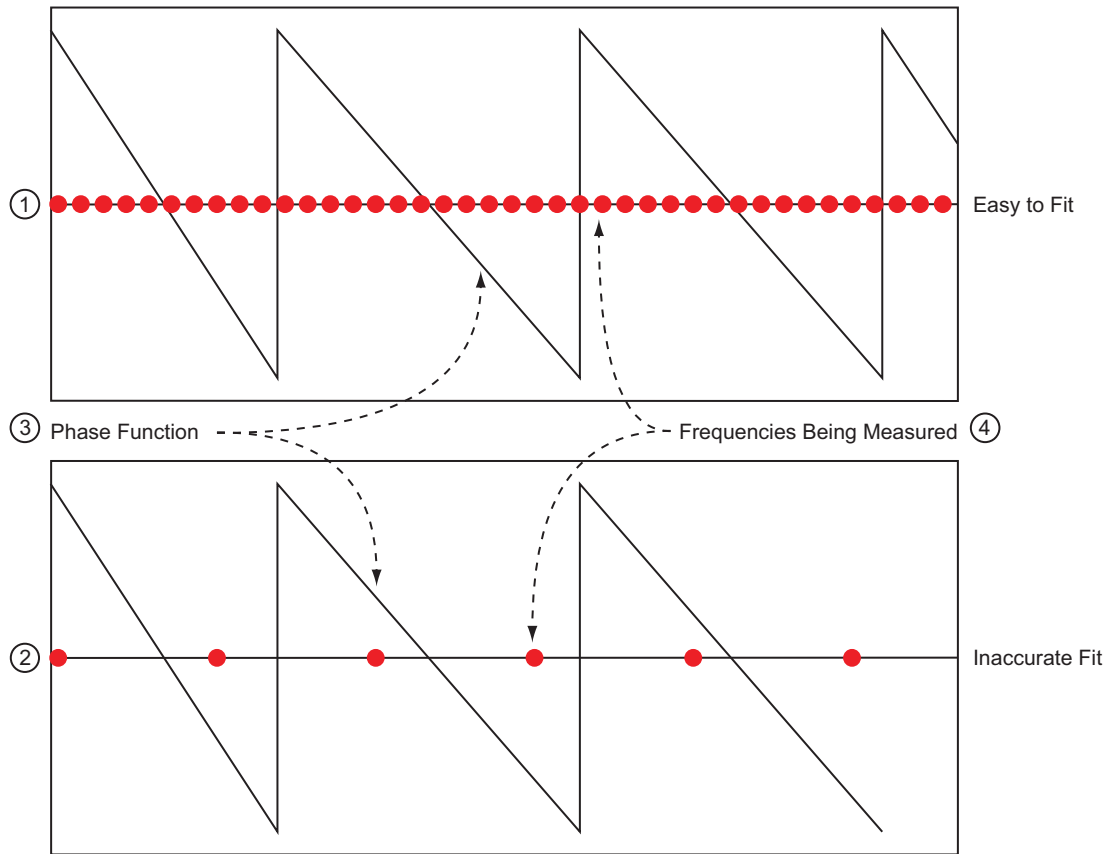


Figure 10-10. REFERENCE PLANE Control Menu

### Auto Button Functions

The Auto button on the Reference Plane menu performs a best fit operation to the current phase data to estimate the equivalent line length. It will attempt to generate a line length that, when removed, will make the phase flat. This routine will be less accurate if the DUT has very non-linear phase (a dispersion function not matching that selected) or if the DUT is electrically long relative to the current frequency step size. This latter problem, related to aliasing, occurs because not enough information is being collected relative to the true behavior of the DUT phase function (see Figure 10-11 on page 10-13). Increasing the frequency point density can help this problem.





- 1. Easier to Fit – Small frequency step size compared to phase function is easier to fit and yields higher accuracy.
- 2. Inaccurate Fit – Larger frequency step size compared to phase function is can produce inaccurate results.

- 3. Phase Function
- 4. Frequencies being measured.

**Figure 10-11.** Auto Reference Plane Function, Frequency Step Large Relative to Phase Period

The auto reference plane function can produce inaccurate results if the frequency step (the distance between the red ovals in the figure above) is large relative to the phase function period.

## 10-4 Impedance Transformation

### 8-4 Impedance Transformation

Most VNA calibrations are performed referenced to 50 ohms as this is usually set by the calibration kit. While some calibration kits exist for other impedances (75 ohm N and F connectors for example), they are not common and a custom impedance may be of interest. The impedance transformation function allows performance of a calibration in one impedance and then transform the result to appear as if it had been calibrated in a different impedance. As a crude example, if a 75 ohm N calibration kit is not available, but a 50 ohm kit is, neglecting issues with adapters, the 50 ohm calibration could be performed and the utility used to reference the results to 75 ohms. The IMPED. TRANSF. (IMPEDANCE TRANSFORMATION) menu for this function is shown below (Figure 10-12).

The ports can be set independently by using the Port Number toggle button and can be set to any complex value except 0 (zero). Generally, a non-real value will only have meaning in a narrowed frequency range.

A calibration with a minimum of 2 ports must be active for impedance transformation to take effect and only those ports currently calibrated will be affected.

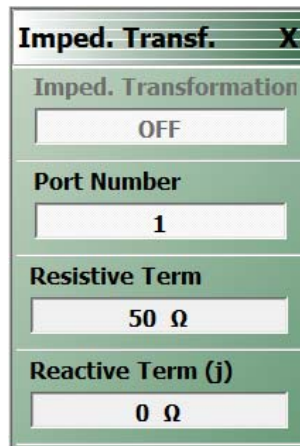


Figure 10-12.IMPED. TRANSF. (IMPEDANCE TRANSFORMATION) Menu

## 10-5 Processing Order

With so many post-processing choices available, it is important to note that the order of operations can matter. A few things are fixed by the way computations are performed and others are changeable to suit user needs. The sequence of computations is as follows for S-parameter measurements:

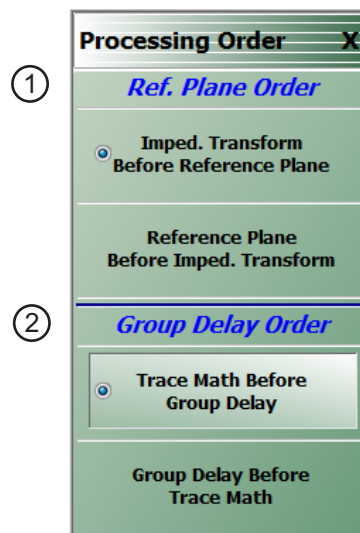
- Acquire raw data and average/filter
- Apply calibration if enabled
- Apply EDE if enabled (impedance transform and reference plane)
- Apply parameter conversions if enabled
- Apply time domain if enabled

### Reference Plane Processing Sequence

The selectable item is the order in which impedance transformation and reference plane control are applied. This matters since the current impedance state determines the impedance of the line length that is adjusted using reference plane control (unlike in E/DE where the impedance can be specified). The menu to make this order selection is shown below (Figure 8-13).

### Group Delay Processing Sequence

The second selectable item concerns the order of the group delay computation and trace memory. If trace memory precedes group delay (normal), then the complex operation can precede the numerical differentiation that is part of group delay. This could be useful to do a data normalization prior to connecting a DUT. If group delay precedes trace memory then the trace match will act on the final group delay result. An example might be a group delay comparison using data(-)memory.



1. Reference Plane Order controls (at top).

2. Group Delay Order controls (at bottom).

**Figure 10-13.**

## 10-6 Conversions

While S-parameters (or the un-ratioed wave parameters) are usually the display variables of interest, conversions to other parameters may be required and are possible with the Shockline™.

1/S is sometimes plotted, particularly for oscillators and other negative resistance devices, where it is desirable to fold the outside of the Smith chart back to the inside. Equivalent impedances and admittances are commonly needed for device modeling and the Z and Y conversions can be used for this (note that these are not, in general, Z and Y parameters).

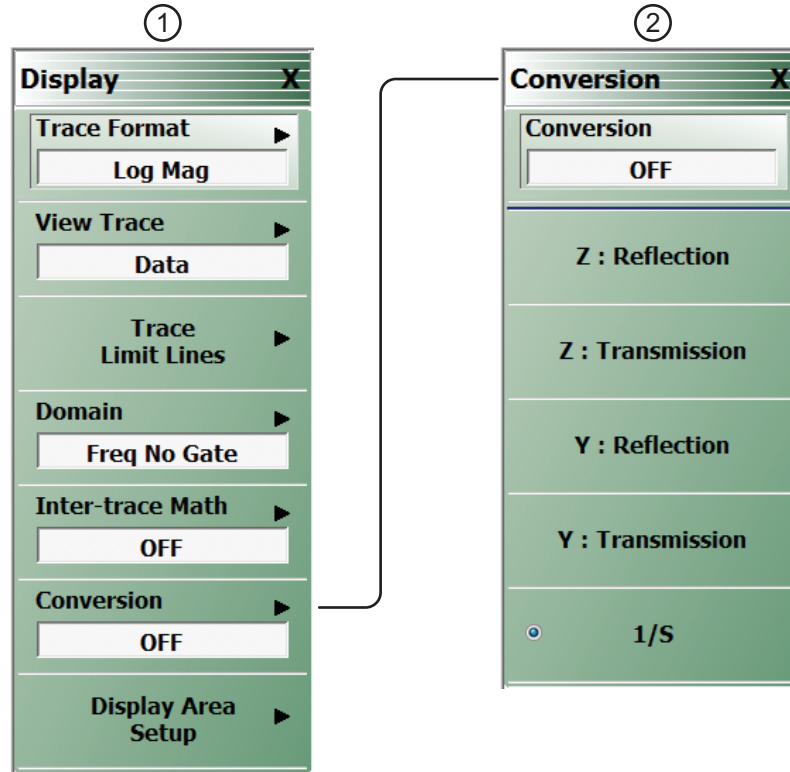
For each of these parameters, a conversion mode of reflection or transmission must be selected which indicates how the current parameter is to be interpreted. The calculations proceed as follows where X indicates the current displayed parameter such as  $S_{11}$ ,  $S_{21}$ ,  $b_1/a_1$ ,  $a_2/a_1$ , and user-defined parameters:

$$\begin{aligned}
 Z_{\text{reflection}} &= Z_0 \frac{1+X}{1-X} \\
 Z_{\text{transmission}} &= Z_0 \frac{2(1-X)}{X} \\
 Y_{\text{reflection}} &= \frac{1}{Z_0} \frac{1-X}{1+X} \\
 Y_{\text{transmission}} &= \frac{1}{Z_0} \frac{X}{2(1-X)}
 \end{aligned}$$

**Eq. 10-2**

Note that reflection Z or Y values here represent shunt impedances or admittances while the transmission values represent series impedances or admittances.

All of the choices available are on the CONVERSION menu shown in the figure below. Note that this function is *PER TRACE* and is located in the DISPLAY menu.



1. DISPLAY menu (on left).

2. CONVERSION menu (on right).

**Figure 10-14.** Conversion Control Menus

The calculations are a function of the current reference impedance which defaults to the calibration reference impedance unless impedance transform has been used (see the section above on [“Reference Plane Control”](#) on page 10-12) or the trace reference impedance has been changed.



# Chapter 11 — Measurement Setup Requirements

## 11-1 Chapter Overview

This chapter provides measurement setup concepts; requirements and options for different types of measurements; describes traces, limit lines, averaging and smoothing, and the organization of their configuration in the system hierarchy.

## 11-2 Traces Introduction

Traces are displays of data elements constituting data groups of up to 16 traces per group, enabling functionality of the system. Each trace can represent a different response parameter, can be on a different graph type, and have different levels of post-processing applied to it.

The objective of this section is to describe trace setups and configurations commonly used.

The hierarchy of system and trace setup information is illustrated in [Figure 11-4](#).

### Per-System Variables

Per-system variables apply to all measurements on a given physical instrument. These variables include:

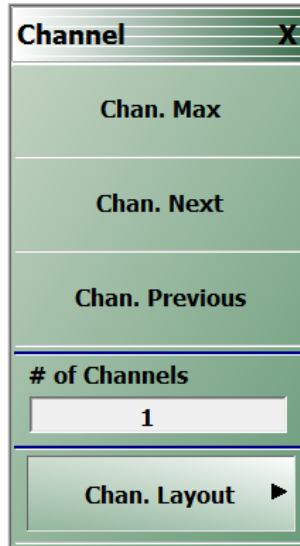
- Portions of the hold system and triggering functionality
- AutoCal characterization files and Cal kit files
- SnP and text file header/format setups
- Blank frequency display security feature
- Interface setup items such as network configuration

### Per-Trace Variables

MS46522B/MS46524B VNAs support a trace count (M) of up to 16. Each trace can have up to 12 measurement markers and 1 reference marker.

## 11-3 Channels and the Channel Menu

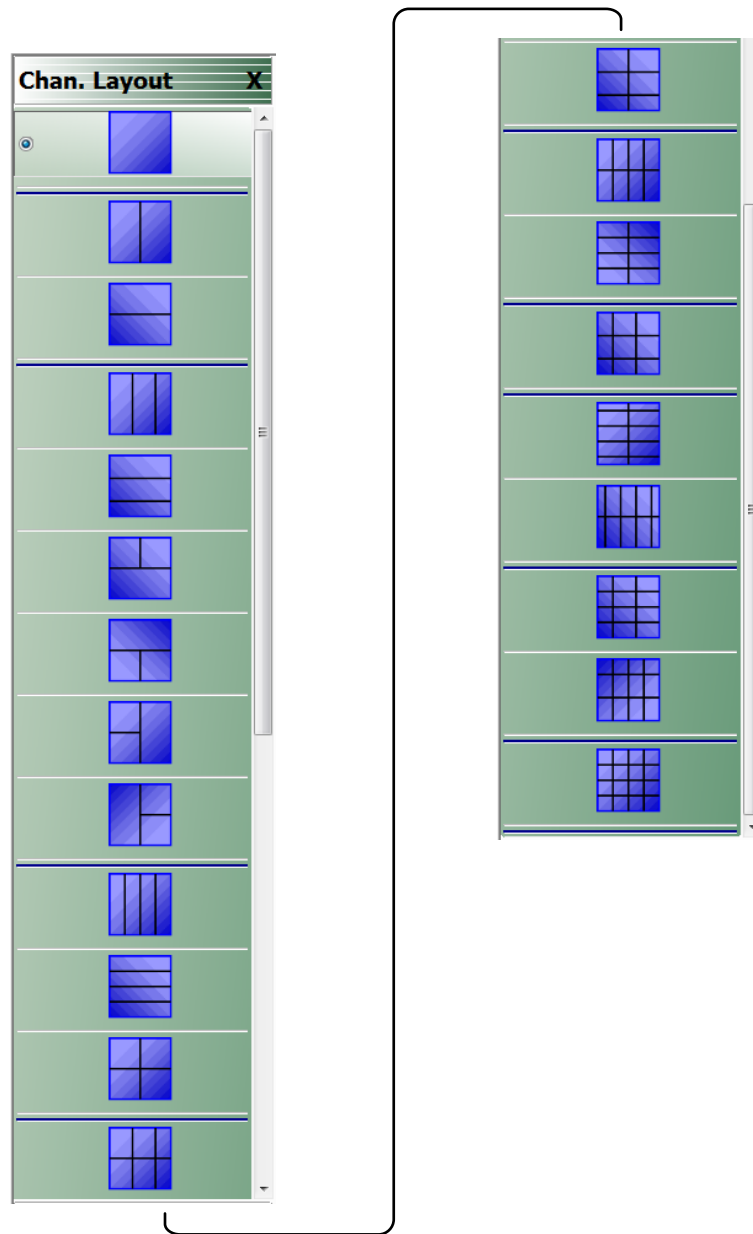
The channel menu itself is fairly simple. While the system defaults to 1 channel (under a preset command), here a different number of channels may be selected. The active channel (indicated by a thick yellow border) may be selected by clicking on that channel's window or it can be incremented using this menu (Chan. Next and Chan. Previous). The button Chan. Max can be used to force the active channel to occupy the entire data screen area. Note that the other defined channels will continue to sweep even when this mode is entered. The Chan. Max command is a toggle and can be undone by clicking it again. Chan. Max can also be accomplished by double-clicking the channel area away from a specific graph (that leads to Trace Max discussed later). These commands are illustrated in the top level menu shown in [Figure 11-1](#).



**Figure 11-1.** CHANNEL Menu

Once a given number of channels is selected, the layout of those channels is selected in a submenu shown in [Figure 11-2](#). Note that selecting a layout with more channels will update the channel count since gaps in the sweep processing are not allowed. Because there are many combinations of channels possible, this window is quite lengthy (shown in two parts in [Figure 11-2](#)).





The instrument menu has a right-side scroll bar to access the entire menu.

**Figure 11-2.** CHAN. LAYOUT (CHANNEL LAYOUT) Menu

Using the CHAN. LAYOUT menu shown in [Figure 11-2](#) above, layouts are limited to values 1, 2, 3, 4, 6, 8, 9, 10, 12, or 16 channels.

Only those values corresponding to semi-symmetric layouts are allowed as suggested by the channel layout menu and other entries will be coerced.

Once the number of channels and the layout has been selected, it then remains to define each of the channels. The sweep control parameters apply to the active channel so one may cycle through the channels entering values as needed. Alternatively, the setups for a channel may be copied through the setup save/recall mechanism since setups can be saved on a per-channel basis. Note that save/recall can also be applied to all channels.

It has been discussed that most sweep-setup parameters are per-channel in nature. To clearly delineate when these apply, the per-channel functions include:

- Frequency
- Power
- Embedding/de-embedding and reference plane extensions
- Impedance transformations (note that this is distinct from impedance parameter conversions which are a post-processing calculation on trace data)
- Post-processing order
- Media type (dielectric constants, coaxial vs. waveguide, etc.)
- Hold functionality (portions can be per-system)
- Trigger functionality (portions can be per-system or per port as well as per-channel)

### Maximum Number of Points Setup

One additional behavior associated with channel count relates to the maximum number of points that may be defined in a sweep. Normally this limit is 20,001 points and this value can be used with any number of channels.

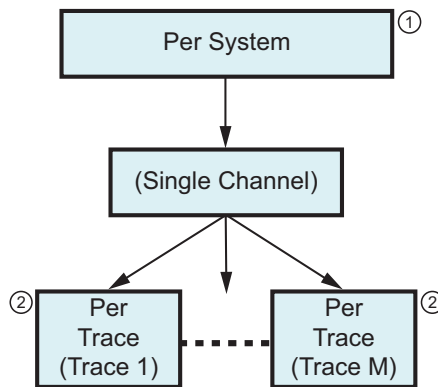
The HOLD FUNCTIONS menu is available from the SWEEP SETUP menu.

- MAIN | Sweep Setup | SWEEP SETUP | Hold Functions | HOLD FUNCTIONS

Note that while triggering can be done per-point and per-port, it still refers to the setup of the channel and it is never reduced to measurements related to a trace. As these hold and trigger functions are used, the actual measurement sequence can of course change.



Figure 11-3. HOLD FUNCTIONS Menu



1 – Per System Settings – These settings affect the entire instrument.

2 – Per Trace Settings – Each trace represents a separate measurement with different display and markers.

Figure 11-4. Setup Information Hierarchy

### Channel Variables

The second tier is that of the channel. As mentioned in the overview, the channel can almost be thought of as a separate virtual VNA. Although this term has been used differently in the past with other Anritsu VNAs, in the MS4652xB ShockLine Series family, the variables include a frequency list, calibrations and sweep control.

### 11-4 Traces

In some sense, the main trace menu is a parallel of the channel menu. Again, up to 16 traces can be specified for display using the # of Traces button of the TRACE menu (Figure 11-5), with sequential trace activation provided by the Trace Next and Trace Previous buttons. Traces can be activated by clicking on the trace title, as shown in Figure 11-6. The active trace is indicated by the trace number highlighted with a solid background.

The Trace Max button toggles display of the active trace to and from the full display area, as does double-clicking on the trace title.

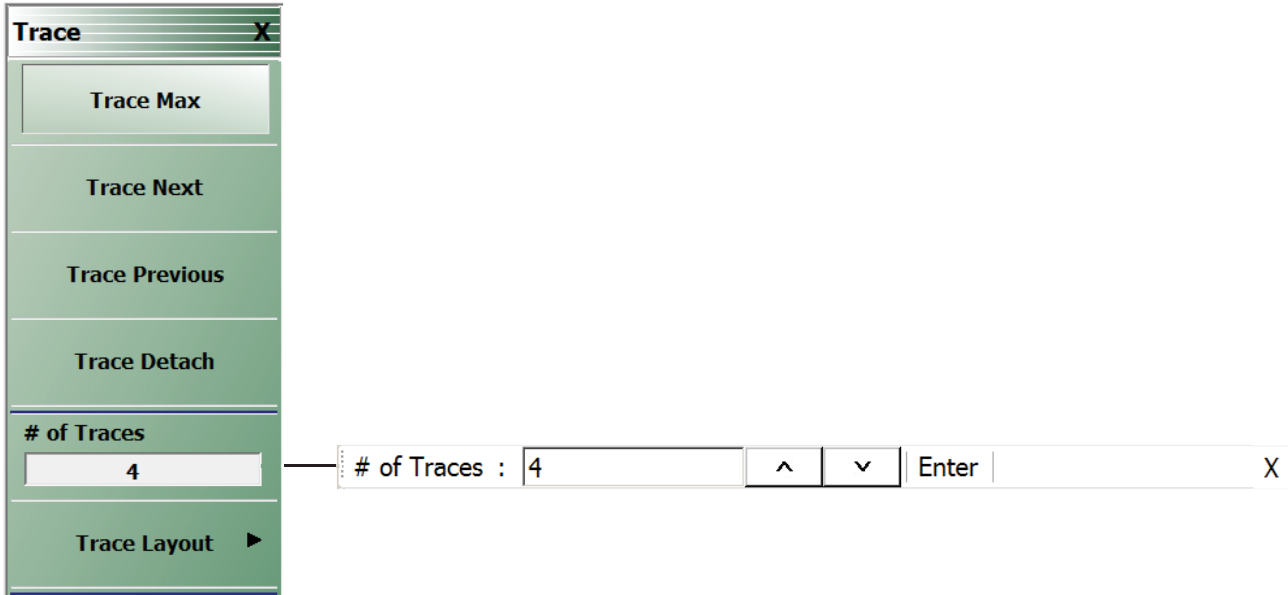


Figure 11-5. TRACE Menu and # of Traces Toolbar

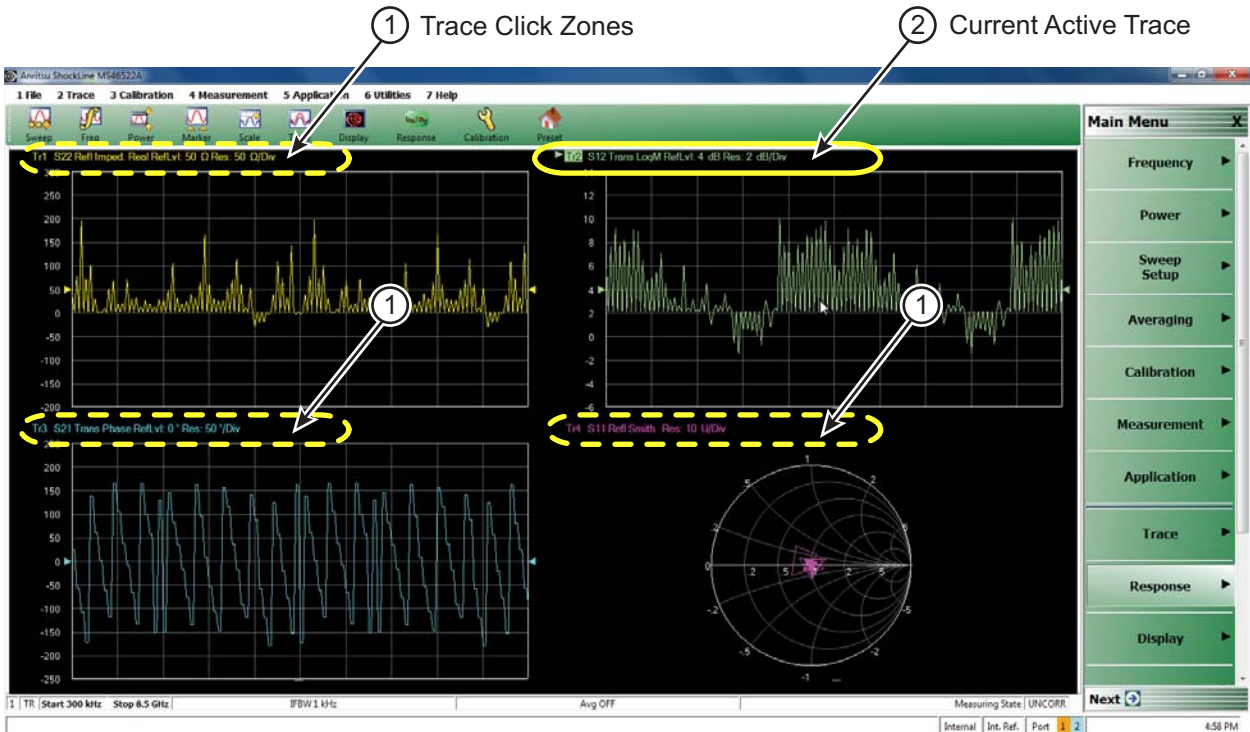


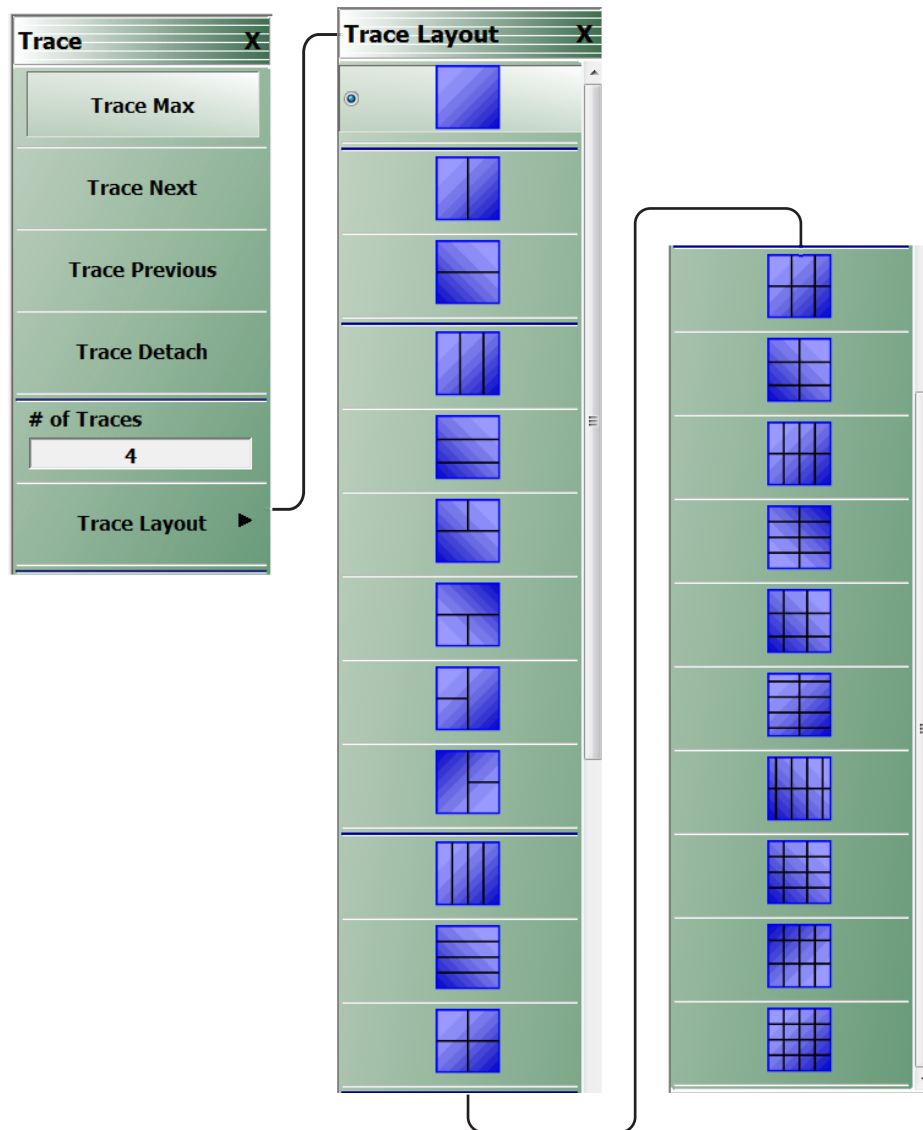
Figure 11-6. Trace Activate Click Zones

The TRACE LAYOUT menu (Figure 11-7) provides 12 trace layout options that support up to 16 traces in any configuration. If the number of traces specified in the # of Traces toolbar exceeds the number of graphs in the selected layout, the extra traces are displayed sequentially as overlays on the trace displays.

For example, if four traces are specified in the # of Traces toolbar with the three vertically stacked displays layout selected from the TRACE LAYOUT menu, the traces will be assigned as follows:

- Top trace display: traces 1 and 4
- Middle trace display: traces 2
- Bottom trace display: trace 3

A 16-trace overlay, and a **16-way** overlay on the MS4652xB family can be displayed by specifying 16 traces and selecting the single graph layout.



**Figure 11-7.** The TRACE LAYOUT menu.

## Per-Trace Variables

Per-trace variables include:

- Trace format (graph type)
- Trace memory and math functions (to include inter-trace math which is sort of a hybrid but is defined on a per-trace basis)
- Scale (although Autoscale can also be per-channel or per-system)
- Trace impedance (which is different from reference impedance set during a calibration)
- Domain (time domain and frequency w/ time gate)
- Smoothing
- Conversions
- Limit lines
- Markers (although markers can be optionally coupled between traces within a channel)
- Response (S-parameter, un-ratioed parameter, external analog in)

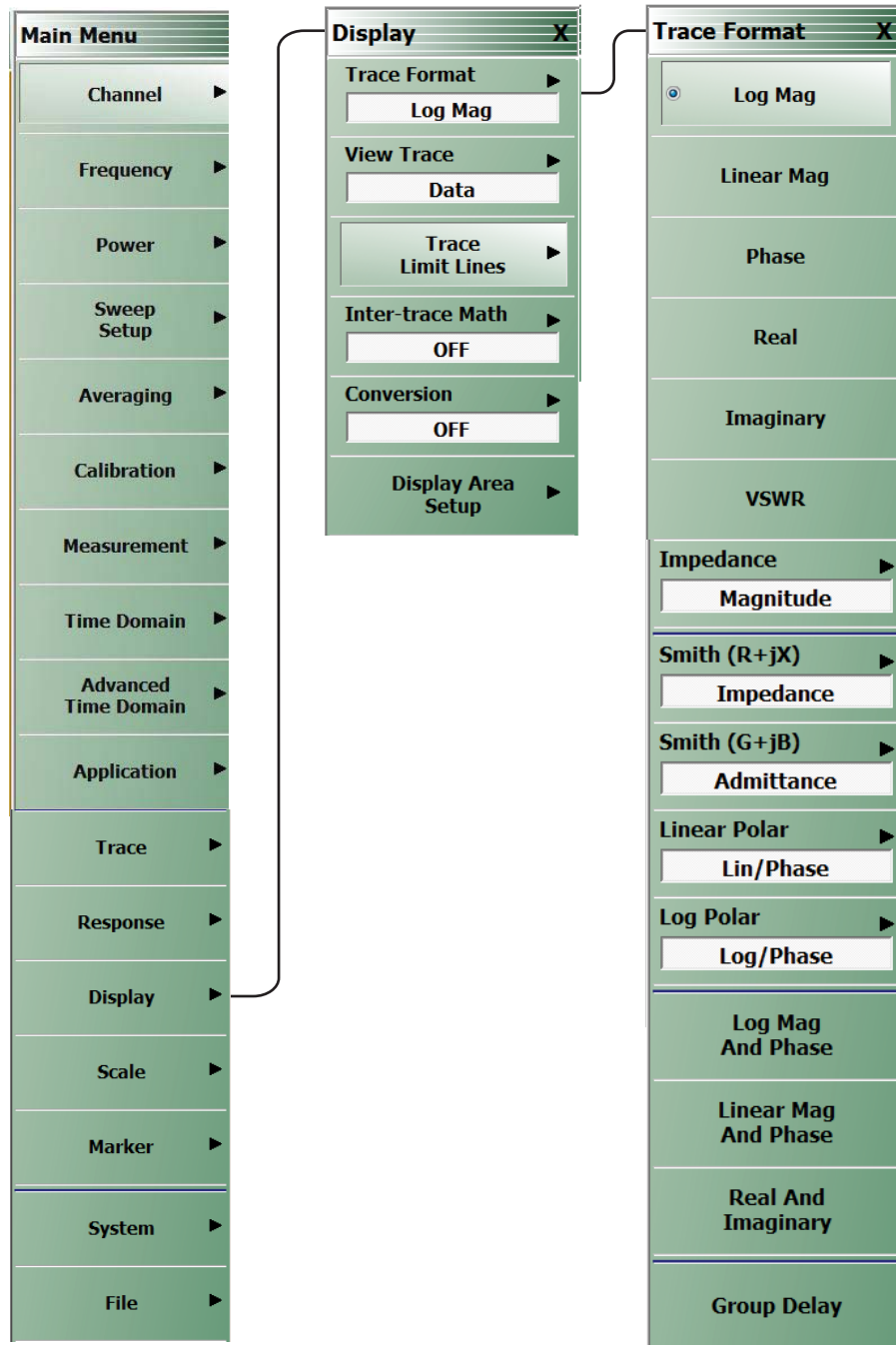


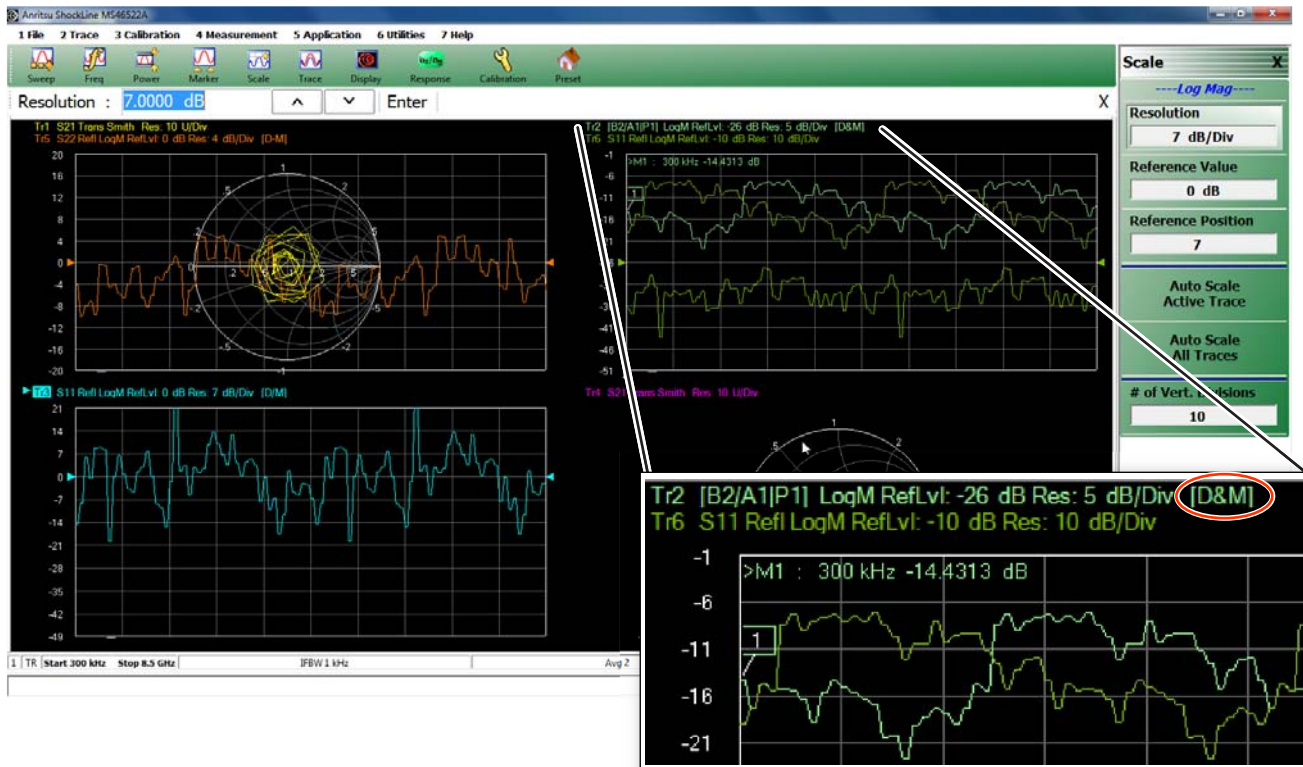
Figure 11-8. TRACE FORMAT Menu

### Complex Trace Setup Example

An example of a complex trace setup is shown in [Figure 11-9](#). This example covers multiple graph types and scaling options as well as different transformations applied to the data in certain traces. Symbols at the end of the annotation line provide information about these trace definitions. For example, Trace 2 is showing Data and Memory [D&M], while Trace 3 and Trace 5 are showing Data Memory Math; [D/M], and [D-M] labels. A list of abbreviations and their definitions are shown in [Table 11-1](#). Some of the abbreviations may appear without brackets at the end of the annotation line. Details on these functions can be found in other sections of this measurement guide and the ShockLine™ Operation Manual.

**Table 11-1.** Trace Labels and Annotations

Abbreviation	Definition
FGT	Frequency domain with time gating
TLP	Time domain low pass
TBP	Time domain bandpass
D&M	Data and memory
D/M	Data memory math
D+M	
D-M	
D-M	
M	Memory



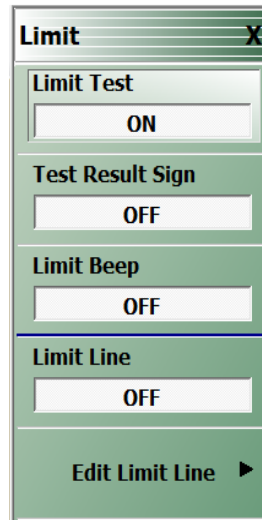
**Figure 11-9.** Multi-Trace Display with right-side SCALE menu

[Figure 11-9](#) also illustrates an example of a function, auto scale in this case, available on per-trace and per-system levels.



## 11-5 Limit Lines

Limit lines are a powerful tool to help quickly compare a set of measured DUT data against specifications or expectations. All limit testing is per trace and, depending on firmware version, limit testing may only be available on rectilinear graph types. Upper and lower limits on any parameter may be set and these may be separated into many frequency bands. There is a limit of a total of 5 segments (upper and lower combined) per trace. The main limit line menu is shown in [Figure 11-10](#).



**Figure 11-10.** LIMIT Menu - Limit Test and Test Result Sign Functions Toggled OFF and ON

### Limit Test

The Limit Test button enables comparison of the data to the limit lines existing (this is per trace). The results of the test (pass or fail) will appear in the upper right corner (see [Figure 11-13](#)) of the graph for that trace.

### Test Result Sign

The Test Result Sign button enables a large graphic displaying the pass/fail result. This will be in the middle of the screen and is visible from a large distance. The Limit Test must be on for this sign to appear. If any limit tests fail, the large fail sign will appear with a notation of which channel has failed.



**Figure 11-11.** Pass and Fail Signs Configured by the LIMIT Menu

### Limit Line

Displays the current limit lines on the data graph. The limit lines will appear in red. Failing points are marked with a red dot.

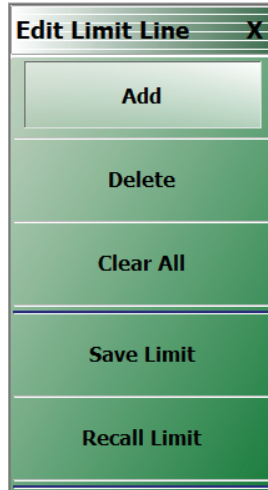
### Limit Fail Signal

Determines the state of the external limit status bit for a fail condition (see next item). High or Low (in a 3.3V logic sense).

### Editing of Limit Lines

Limit lines are edited using the Edit Limit Line menu shown in [Figure 11-12](#). The Edit Limit Line menu displays along with the limit line table shown in [Figure 11-13](#). The limit line tables may be saved and recalled separately using this menu, or they may be saved and recalled as part of the global setup using File menu commands.

### Edit Limit Line Menu



**Figure 11-12.** EDIT LIMIT LINE Menu

A limit line table is shown in [Figure 11-13](#) with two pairs of upper and lower limit segments.

#### Type

Each segment can be configured as Upper, Lower, or Off using the drop-down menu to make the selection.

#### X1 and X2

The constraints of the segment in the X-direction. Usually this variable will be frequency (segmented or linear frequency sweeps) but it could be time (time domain) or power (power sweep). If two segments cover the same frequency range (or portions thereof), the first segment will have precedence.

#### Y1 and Y2

The constraints of the segment in the Y-direction. These will have units of the graph type for the active trace (dB in the examples here).

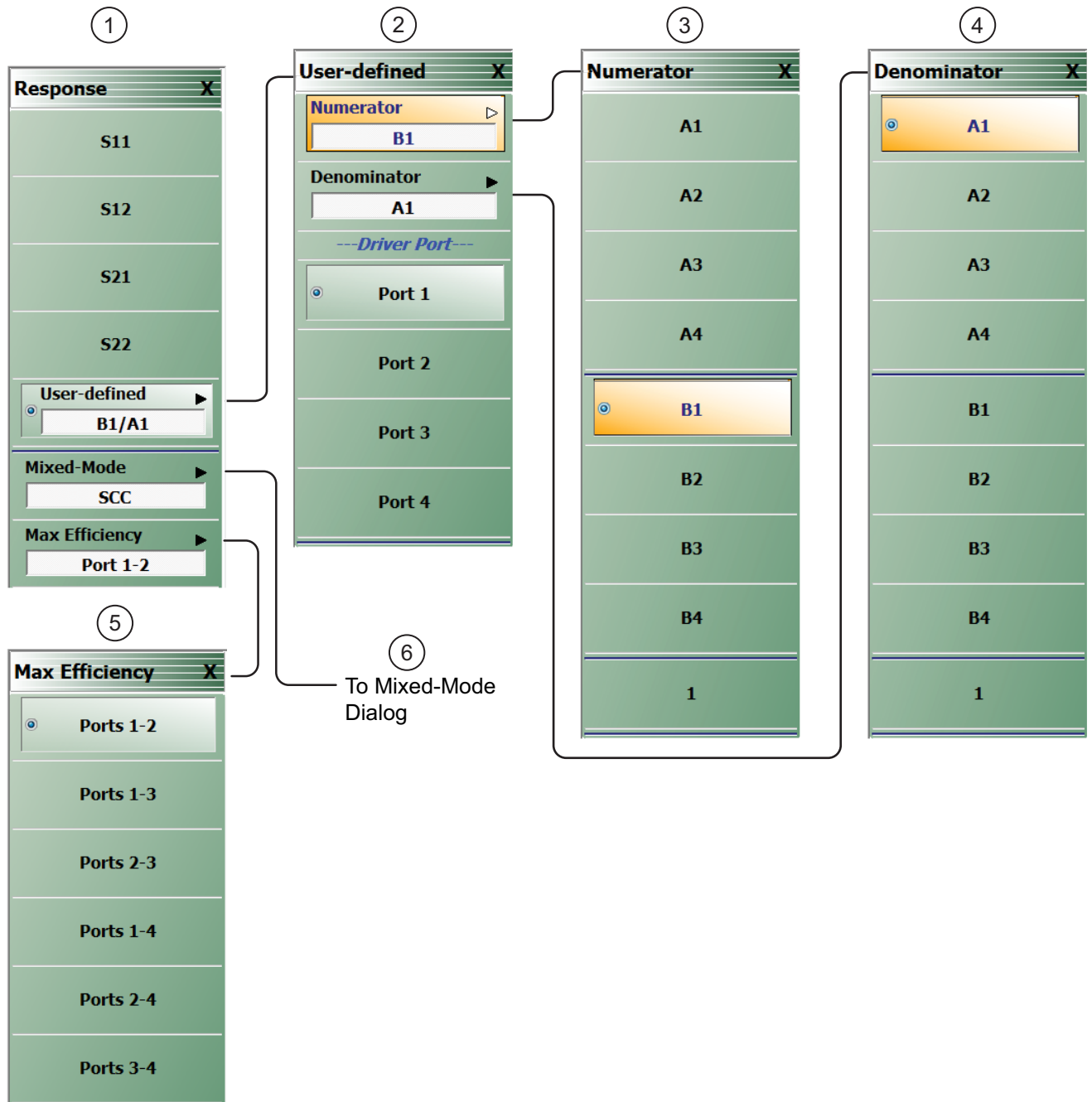
Type	X1	X2	Y1	Y2	X Offset	Y Offset
1 Upper	30 MHz	7 GHz	9.8 dB	9.8 dB		
2 Lower	300 kHz	8.5 GHz	9.8 dB	9.8 dB		
3 Upper	3 MHz	4 MHz	9.8 dB	9.8 dB		
4 Lower	5 MHz	10.5 MHz	9.8 dB	9.8 dB		

**Figure 11-13.** Limit Line Table

The X offset and Y offset values allow one to shift both indices in a row by a constant amount. This can be useful in copying multiple rows and, for example, incrementing by a fixed frequency offset.

## 11-6 Response Menu

These are selectable on the response menu as shown in [Figure 11-14 on page 11-13](#) below. The submenu allows a choice of which port is driving during that particular analog in measurement. This port selection may be important particularly with the use of external power detectors.



1 – RESPONSE menu

2 – USER-DEFINED menu

3 – NUMERATOR menu

4 – DENOMINATOR menu

5 – MAX EFFICIENCY menu

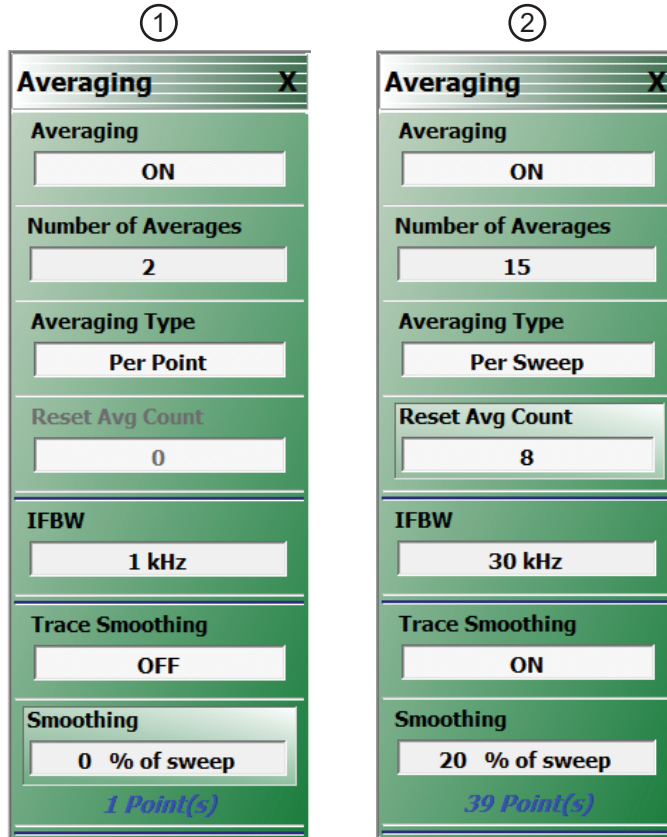
6 – To Mixed-Mode dialog

**Figure 11-14.** RESPONSE Menu and Submenus

## 11-7 Averaging and Smoothing

### Overview

Averaging and smoothing are extensively covered in the operations manual, but there are some measurement-related impacts that should be discussed in this section. The control menu is repeated in [Figure 11-15](#) for reference.



1. IFBW set to 1 kHz and Trace Smoothing set to OFF.

2. IFFBW set to 30 kHz; Trace Smoothing set to ON with Smoothing applied to 20% of sweep.

**Figure 11-15.** AVERAGING Menu - Both menus show that averaging has been toggled on.

### Averaging

The Averaging button toggles the function OFF and ON.

### Number of Averages

The Number of Averages button displays the number of measurements performed at each frequency point in the case of per-point averaging, and represents the number of sweeps averaged for per-sweep averaging.

## Averaging Type

The Averaging Type button toggles between per-point and per-sweep averaging.

- **Per-Point Averaging**

Per-point averaging acquires additional samples at each frequency (or power) point and performs the averaging process at that time. This is similar to an IFBW reduction (adding 10 per point averages is equivalent to a 10x reduction in IFBW). Since the time between sample acquisitions is small in this case, per point averaging works best at removing high rate noise.

- **Per-Sweep Averaging**

Per-sweep averaging averages a given frequency (or power) point's behavior on subsequent sweeps. This can be a very long time constant between samples (depending on sweep speed) so this type of averaging does best with low rate noise.

Per-sweep averaging is performed on a rolling basis with the most recent sweeps used to compute the result.

Since per-sweep averaging has a long time constant, setup changes or DUT changes can appear to have an odd effect. Powering down an active DUT, for example, may lead to an S21 display to slowly drift away since it takes some time for the gain change to work its way through the sweep count. If a setup or DUT change is made, it may be desirable to reset the averaging count.

## Intermediate Frequency Bandwidth

The Intermediate Frequency Bandwidth (IFBW) is allowed in the range of 10 Hz to 500 kHz on the MS46522B/MS46524B VNAs. At lower IFBW<sub>s</sub>, additional per point averaging has little effect.

At very low frequencies, where the IFBW may be on the order of the system frequency, there could be measurement issues. By default, the IFBW will be limited at system frequencies below 3 MHz although this can be overridden under the System menu.

## Trace Smoothing

Trace smoothing is toggled OFF and ON by this button. Trace smoothing performs a weighted averaging around each frequency point using a window size set by the percentage of smoothing. Since this process combines data at different frequency points, it should be used with care since it can remove valid frequency response information.

## Averaging and Smoothing Conclusions

In time domain, averaging and IFBW apply to the basic frequency domain data. Smoothing applies to the time domain data.



# Chapter 12 — Measurement - Time Domain (Option 2)

## 12-1 Chapter Overview

This chapter provides time domain measurement guidelines and procedures. General descriptions, key concepts, and example procedures are presented for time domain measurement modes of low pass, bandpass and gating.

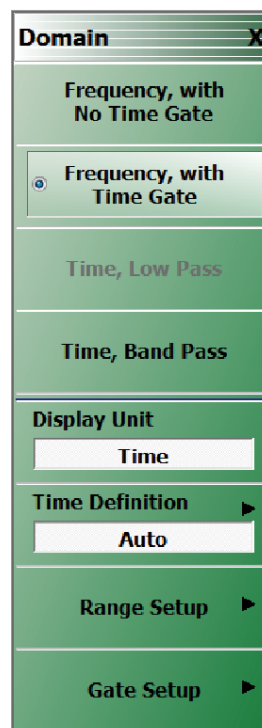
## 12-2 Introduction

The time domain option offers the ability to transform the native frequency domain data of the MS4652xB ShockLine into time domain information for TDR-like displays, distance-to-fault analysis, and general spatial-based circuit and network troubleshooting. Uses for time domain include:

- Identifying mismatches/discontinuity locations in fixture or PC board launch structures.
- Locating and quantifying defects in a cable assembly.
- Identifying characteristics of discontinuities (inductive or capacitive) within fixture or on-wafer transitions.
- Semi-quantitative determination of impedance levels in a cascaded series of transmission lines.

Time domain is a per-trace invocation allowing frequency domain and time domain traces to be freely mixed on any response parameter, but since there can be only a single x-axis domain readout per trace display, the domain readout is in the units of the active trace.

The DOMAIN menu shown in [Figure 12-1](#) provides time domain controls. It is accessed from the DISPLAY menu.



**Figure 12-1.** TIME DOMAIN Dialog

## 12-3 Basic Time Domain Modes

The four basic modes of the Time Domain menu are:

- **Frequency With No Time Gate**  
Regular frequency sweep mode.
- **Frequency With Time Gate**  
Frequency domain data passed through gated time domain providing time-gated response for evaluation in the frequency domain.
- **Time, Low Pass**  
Time domain mode where frequency content close to DC is available (start frequency no more than about 10 step sizes). Step response (like a TDR) processing is available and resolution better, but this mode may not be available for all frequency lists. The selection will be unavailable if incompatible.
- **Time, Bandpass**  
Time domain mode for any frequency sweep. Only impulse response can be displayed. Defect identification tools are more limited, and resolution is worse by a factor of 2 compared to low pass for the same sweep width. This is the only choice in band-limited scenarios such as waveguide.

## 12-4 General Concepts

### Chirp-Z Transform

The time domain functionality is provided by a chirp-Z transform (in most cases) of the available frequency domain data for that parameter. Since the transform simply treats the frequency domain values as input data, any parameter can be transformed. Unratioed parameters are less useful since they do not contain phase information that the transform relies upon.

The chirp-Z transform is, in a macro sense, very similar to the Fast Fourier Transform with the exception that the output range can be variable. This allows the ability to specify an arbitrary time range to look at while maintaining the desired point count. A different algorithm is used with dispersive media, such as waveguide and microstrip where the time-frequency relationship is more complex, but the functionality remains the same.

### Defects as Impulse Functions in the Time Domain

Defects can be considered to be impulse functions in the time domain. This sum of impulses transforms to a sum of complex exponential in the frequency domain. While these produce the characteristic ripples seen in frequency domain data of mismatched systems, the frequency domain data can be hard to interpret as to the location of the defects causing the ripples. This is the value of a time domain analysis.

### One-Way or Round Trip Time

One question that arises is whether the time (or distance) plotted represents a one-way or round trip time, particularly in the case of reflection measurements. The time definition dropdown selection, shown in [Figure 12-1 on page 12-1](#), controls this behavior. When in Auto, the system will always display one-way times and detects whether the measurement parameter is reflection or transmission to help sort that out. If using user-defined parameters or unusual loop-access configurations, going to manual control may be needed. The transform itself will generate a round-trip time for reflection and a one-way time for transmission without any intervention from the system.

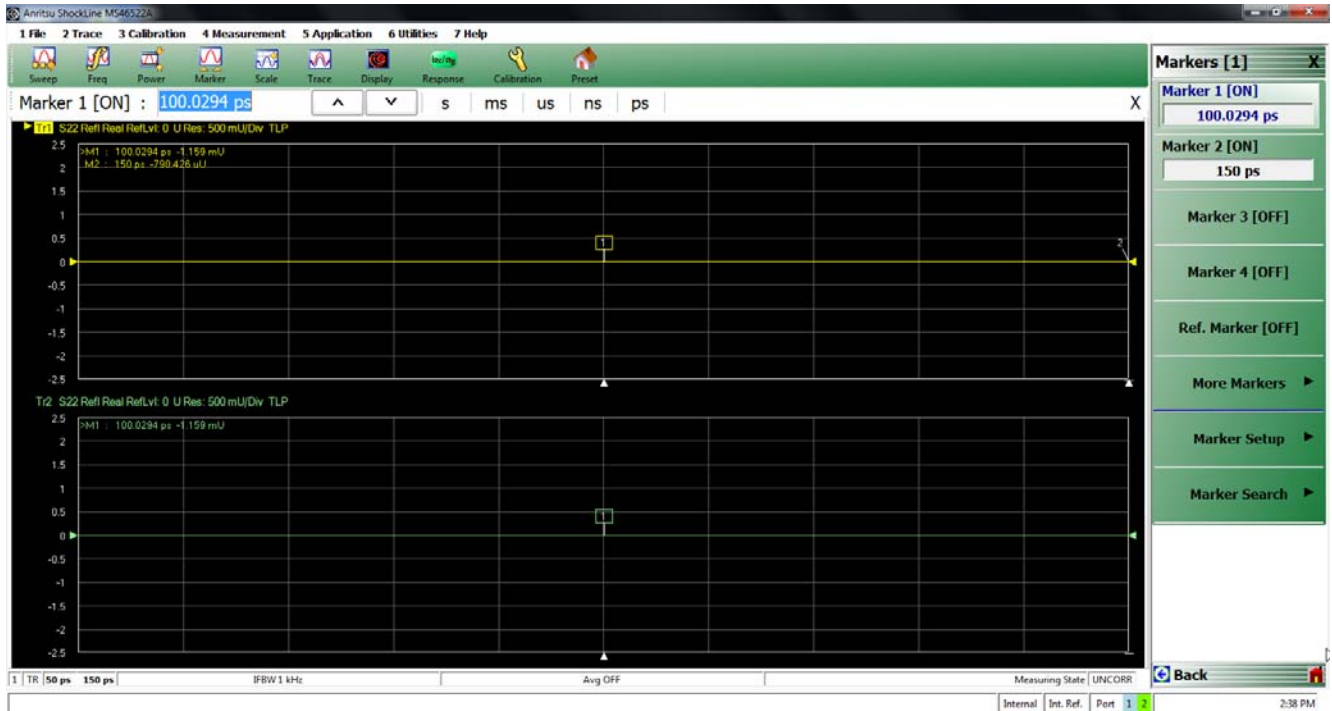
**Note**

The following menus are accessible through the Display sub menus. Users can access these same features through the Measurement Setup dialog menu.



## 12-5 Low Pass Mode

Low pass mode assumes the existence of data near DC which enables the ability to compute step responses and to create a pure real transform. While any graph type can be used (except Imaginary which would have a flat line), Real is sometimes the most valuable since information about the defect can be determined. An example plot showing a short at the end of a small transmission line length of approximately 100 ps appears in [Figure 12-2](#). Both the impulse response and step response are plotted on real graph types. Many aspects of this plot will be discussed in this section including the impulse and step presentation of the same data.

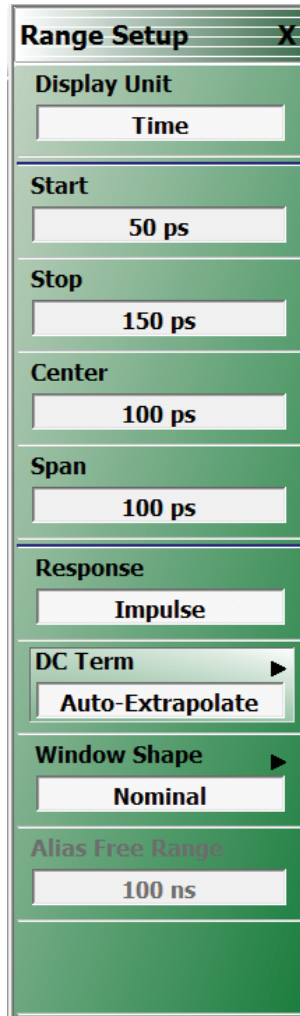


**Figure 12-2.** Example Low-pass Time Domain Plot

Many of the other submenus change slightly depending on which mode is selected so the remaining subsections will be partitioned according to the mode.

## Range Setup Menu Functions

The Range Setup menu for low-pass time domain is shown in [Figure 12-3](#). The top button, Display Unit, toggles between Time and Distance and is a duplicate button to the Display Unit button on the DOMAIN menu ([Figure 12-1](#)).



**Figure 12-3.** RANGE SETUP Menu - Time, Low Pass Domain

The fundamental output of the transform depends on the non-dispersive or dispersive nature of the media. In the case of non-dispersive media (to include coax), time is the fundamental output of the transform and distance is calculated using the media information on the measurement menu. In the case of dispersive media (waveguide or microstrip), distance is the fundamental output and time is calculated from that.

The **Start**, **Stop**, and **Center** buttons all invoke field tool bars that allow user-input for each value (in distance or time); with the **Span** button displaying the calculated result. There are few limits to what may be entered but extreme entries may not always be useful due to constraints of resolution and alias-free range. These limits are determined by the frequency list used as well as the window selected.

Resolution is interpreted as impulse width (the width of a singular defect) while alias-free range is the maximum time range that can be studied before defects start repeating themselves (due to the cyclical nature of the transform). To help, the resolution (impulse width) is displayed as a read-only variable on the main time domain menu ([Figure 12-1](#)) and the alias-free range is displayed on this range menu as a read-only variable.

The response choice is either Impulse or Step. The step response, which allows a TDR-like display is simply an integration of the impulse response which is the natural output of the transform. However, since the ShockLine™ MS46522B/MS46524B VNA cannot get all the way to DC, some additional information is needed to perform this integration. To see this consider:

$$\text{ImpulseResponse} = \mathfrak{F}^{-1}\{X(\text{DC})\} + \{X(\text{sweepRange})\}$$

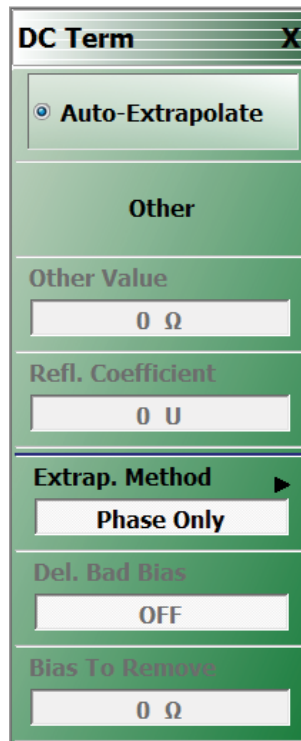
$$\text{ImpulseResponse} \approx A \cdot X(\text{DC}) + \mathfrak{F}^{-1}\{X(\text{sweepRange})\}$$

$$\text{StepResponse} = \int_0^t [A \cdot X(\text{DC}) + \mathfrak{F}^{-1}\{X(\text{sweepRange})\}] dt$$

**Equation 12-1** TDR Integration Equation

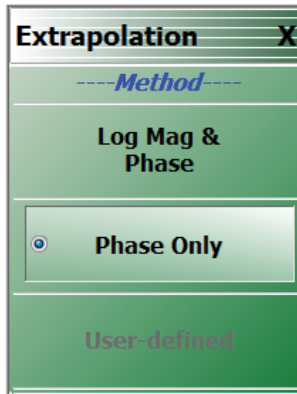
### DC Term Menu

Since the DC value ends up being integrated from time 0 (zero), the value used here is quite important and the choices to compute this value are shown in [Figure 12-4](#). The default choice is to allow the system to auto-extrapolate from existing frequency data to estimate the DC value.



**Figure 12-4.** DC TERM Selection Menu

There are options on how the extrapolation is done, as shown in [Figure 12-5](#).

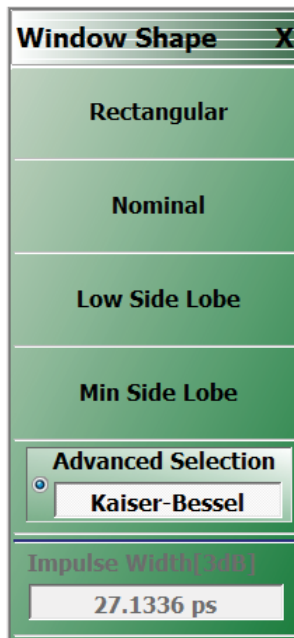


**Figure 12-5.** The DC Term EXTRAPOLATION Menu

The default method, Mag-Phase, extrapolates both portions as would be expected and is energy-conserving. For cases where the start frequency is low and the DUT loss changes slowly over frequency, sometimes the magnitude may be assumed constant and only the phase function need be extrapolated (most common with long cable assemblies). The other option allows a table of low frequency values to be entered (two-column, tab-delimited). If the DUT is well-known, extrapolation can be avoided altogether by entering the DC impedance.

### Window Shape Menu

The last item on the Range Setup menu is the Window Shape selection button which displays the Window Shape submenu shown in [Figure 12-6](#).



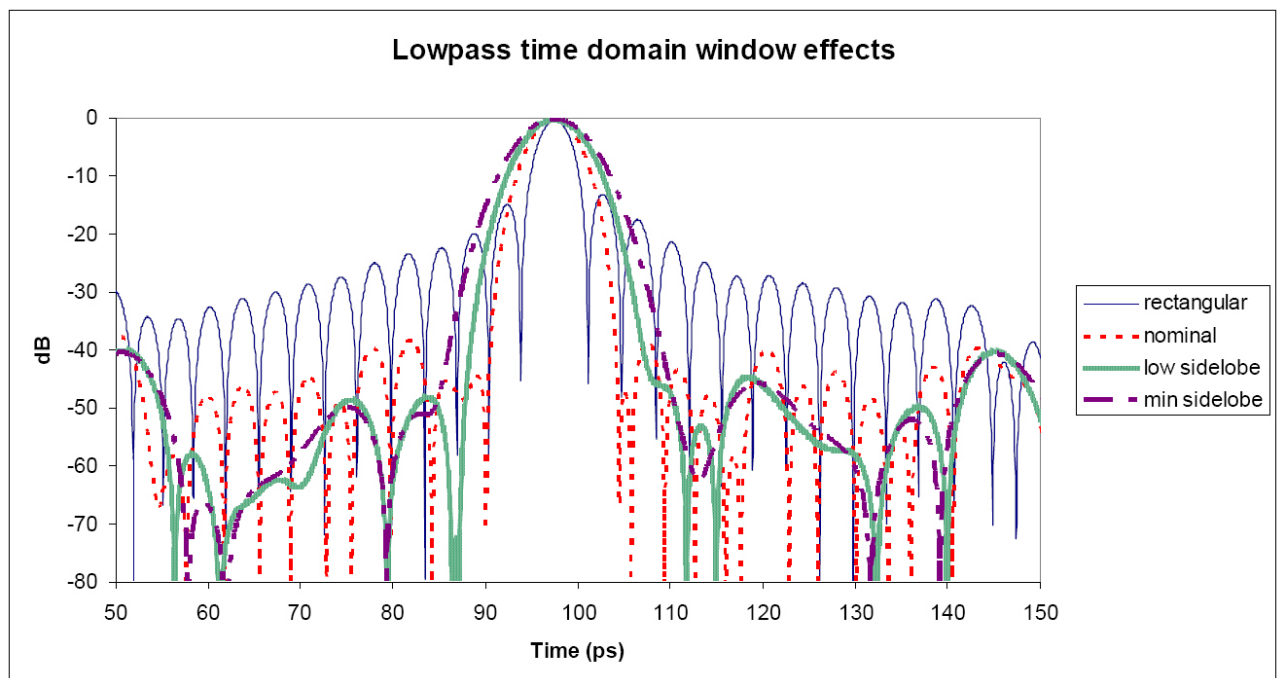
**Figure 12-6.** WINDOW SHAPE Menu

Since the frequency range of the VNA is finite, the frequency domain data will have a discontinuity at the stop frequency. This introduces side lobes in the time domain data that can obscure smaller defects and hamper separation of defects. The window provides some pre-processing of the frequency domain data to reduce the severity of the discontinuity and hence the side lobe level. This also reduces resolution but is unavoidable.

The Nominal window is the default and provides about half of the resolution of Rectangular (no window) but with an approximate 30 dB reduction in side lobe levels. The Nominal window is advised for most applications.

Since the window so strongly affects resolution, the Impulse Width display is repeated on this submenu to help determine the impact on the desired measurement.

An example of how the window shapes affect the impulse data (main lobe width and side lobe level being traded-off) is shown in [Figure 12-7](#). Here the same data appears with the four different window selections. For this plot, data was saved to TXT files and plotted externally.



**Figure 12-7.** Effects of Window Shapes Plot

The Advanced Window selection button brings up the dialog shown in Figure 12-8 that has the previous four choices along with two new parameterized windows, Kaiser-Bessel and Dolph-Chebyshev.

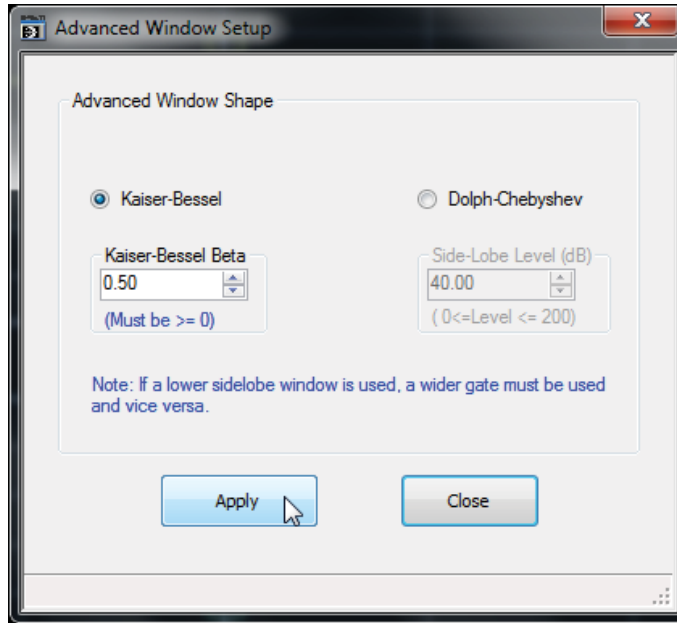


Figure 12-8. Advanced Window Setup Dialog

The dialog for advanced window setup makes two new window choices available (Kaiser-Bessel and Dolph-Chebyshev). The Apply button must be used for a radio-button selection to take effect.

These two new window types allow for a finer selection of the trade-off between side lobe level and resolution. For the Kaiser-Bessel window, a larger Beta value leads to lower side lobes, but a wider main lobe width (and hence poorer resolution). For the Dolph-Chebyshev window, the side lobe level is parameterized explicitly (in absolute dB) and a larger value leads to a wider main lobe width as well. The windows for two parameter values for each of these windows are shown in Figure 12-9 along with the rectangular window for comparison.

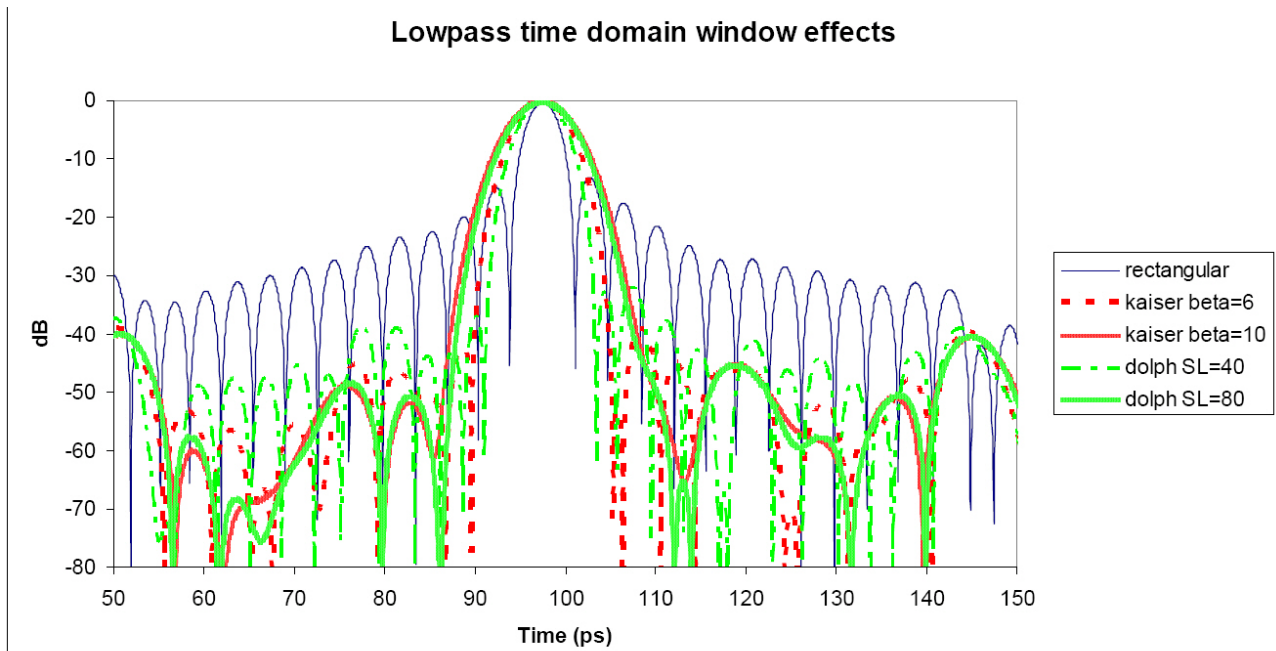


Figure 12-9. Effects of Window Shapes Plot with Advanced Windows Selection

The approximate relationship between these parameters and the main lobe width (null-to-null) is suggested in [Figure 12-10](#). Here, everything is scaled relative to a rectangular window (a nominal window is at 2, a low side-lobe window is at 3, and a minimum side-lobe window is at 4 on this scale) and the y-axis is normalized relative to the lobe width of a rectangular window.

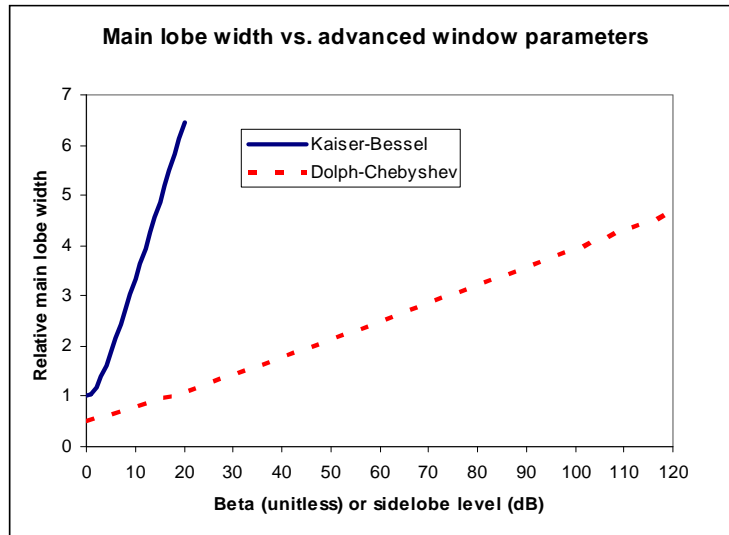
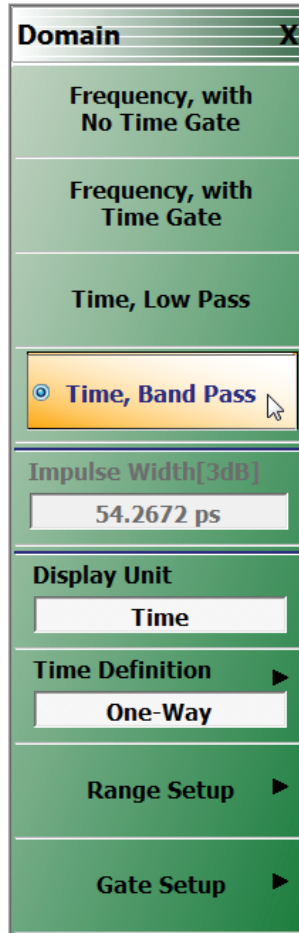


Figure 12-10. Comparison of Lobe Width vs. Window Parameters

## 12-6 Bandpass Mode

The Bandpass Time Domain mode is similar to low pass but a few menu items change. Any graph type can be used with bandpass mode but log magnitude and linear magnitude are the most common. The top level of the time domain menu is repeated in [Figure 12-11](#) for convenience. This menu level does not change between the time domain modes. An example measurement (of a short on a transmission line like in [Figure 12-2](#)) is shown in [Figure 12-12](#). Here, a real and imaginary plot is shown to illustrate the difference from the pure real low pass time domain result but this graph type is not commonly used in practice.



**Figure 12-11.** Top Level DOMAIN Menu - Time, Band Pass Selected



An example bandpass time domain plot is shown below for a short at the end of a transmission line. In a log magnitude display, there is a single impulse of approximately unity amplitude near the 100 ps mark.

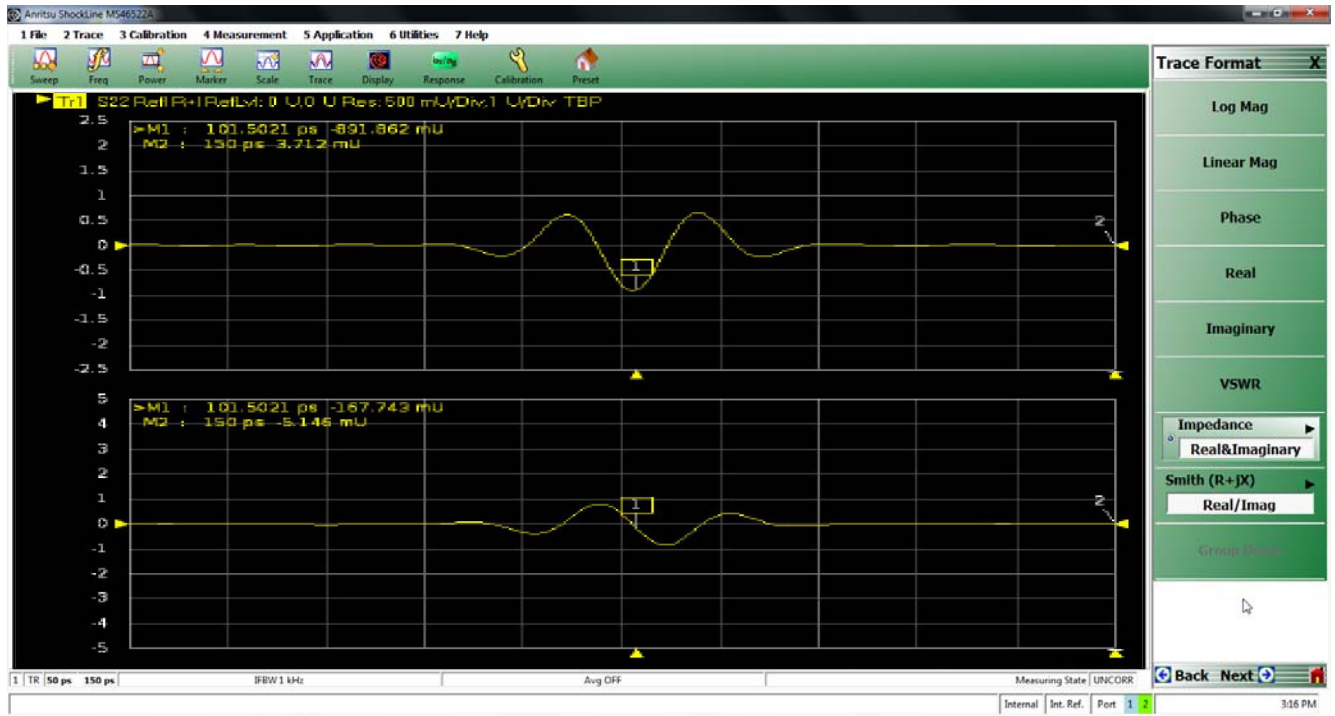
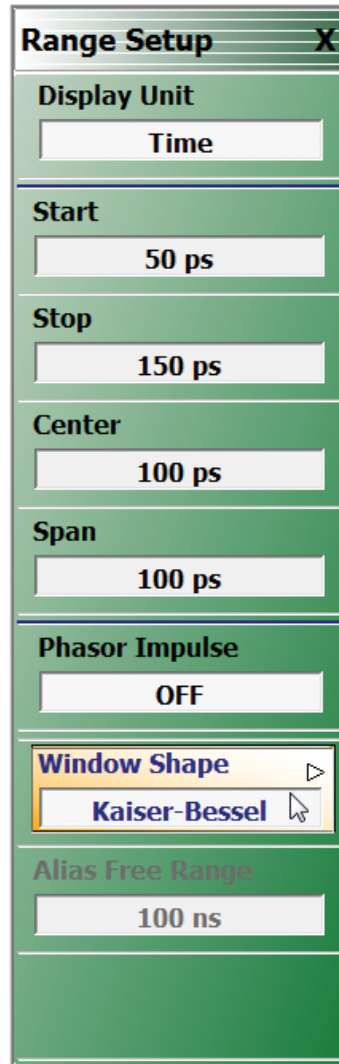


Figure 12-12. Example Band-pass Time Domain Plot

The range menu for bandpass mode is shown in [Figure 12-13](#). The differences here are that the response choice and DC terms are gone since they do not apply to this mode, and a new item appears: Phasor Impulse.



**Figure 12-13.** RANGE SETUP Menu for Bandpass Time Domain

In low pass mode, the sign of the data can be used to provide some hints as to the nature of the defect (inductive or capacitive). It is less obvious in bandpass mode since the time domain data is complex. A function termed Phasor Impulse Mode is an attempt to simulate the data reduction of low pass mode when operating in bandpass mode. It is only correct if the defect can be described by a single defect (a single complex exponential in the frequency domain). The range should be adjusted to have one peak on screen occupying a reasonable fraction of the span. The Phasor Impulse function processes this single peak to produce a pure real transform carrying sign information much like lowpass mode (positive for inductive, negative for capacitive).

The window shapes have the same effect as in low pass but the starting resolution is only half that of low pass (the window effects are multiplicative). The window effects are illustrated in Figure 12-14 and correspond to the measurement of Figure 12-12 on page 12-11, but expressed in log magnitude. Note the trade-off of side lobe height for main lobe width and that the lobe width is twice that for low pass (Figure 12-7 on page 12-7).

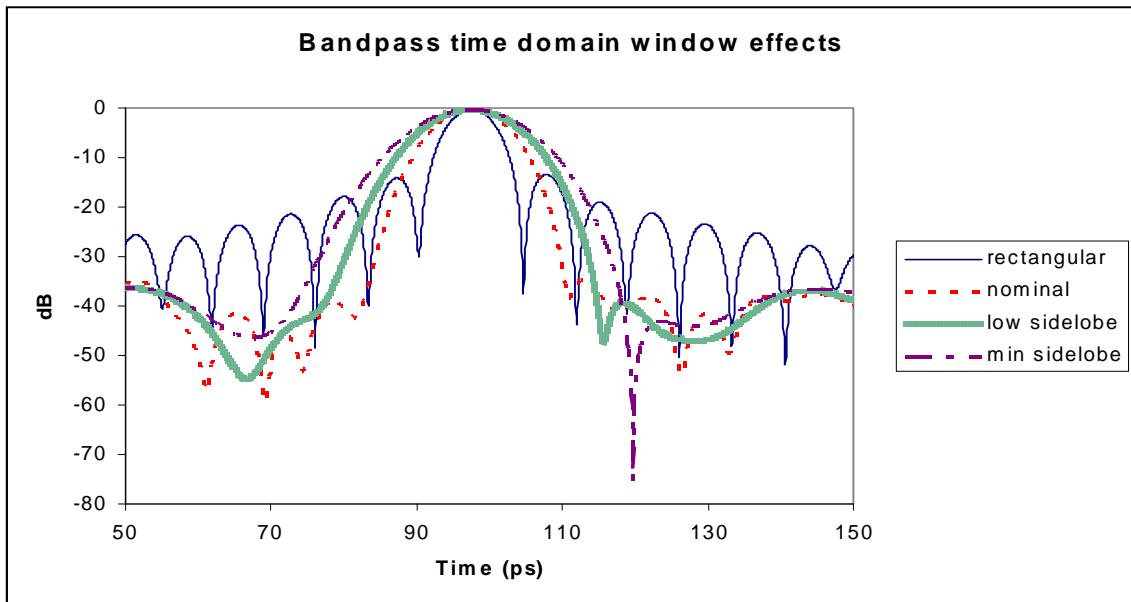


Figure 12-14. Window Effects in Bandpass Time Domain

As with lowpass time domain, the Advanced Windows are also available. Some example results are shown below compared to the rectangular window for a few parameter values.

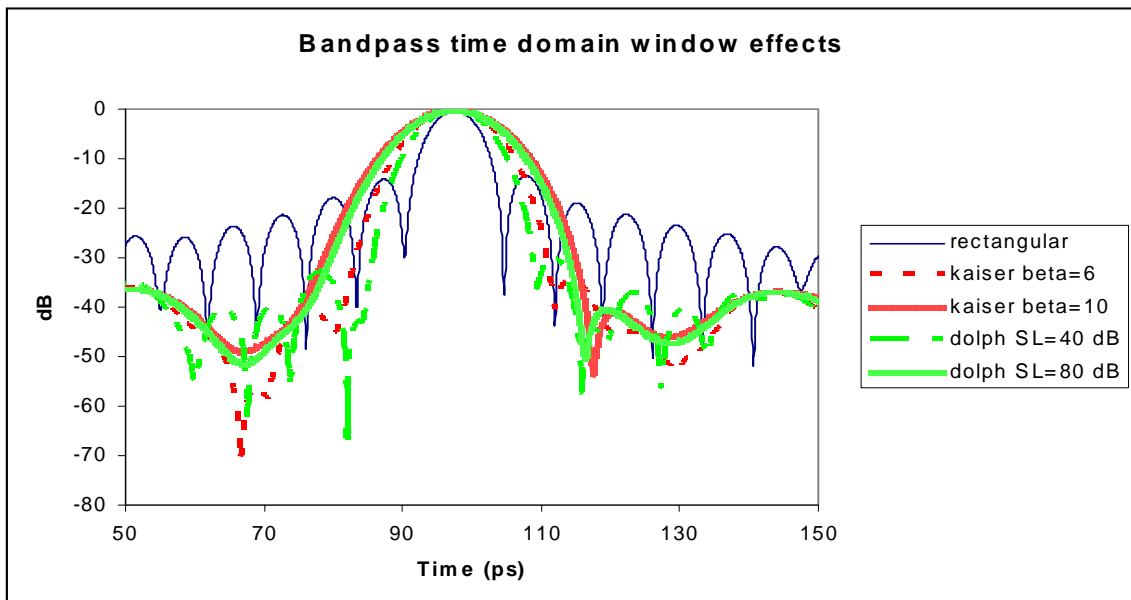


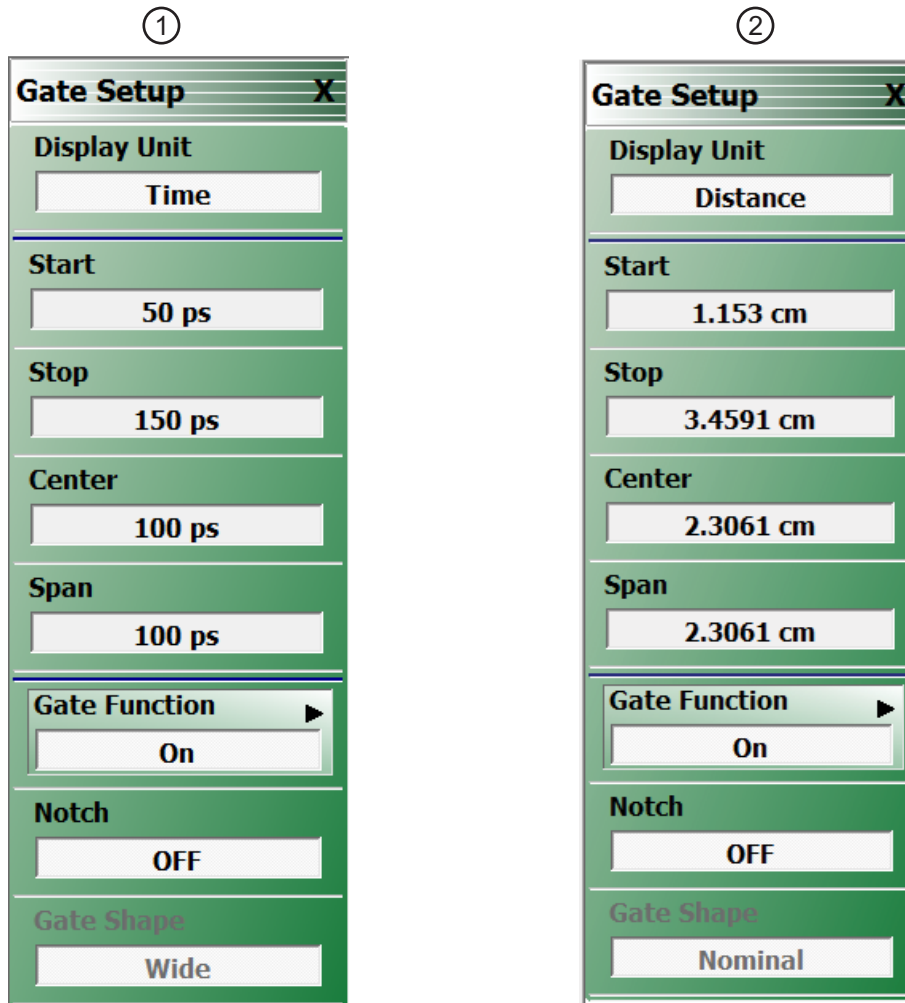
Figure 12-15. Window Effects in Bandpass Time Domain (advanced window types)

## 12-7 Gating

Both lowpass and bandpass work similarly with regards to gating. Gating is the process of selecting or deleting certain defects to study. This can be left in time domain but, more commonly, the gated results are fed back through the forward transform to get the frequency domain result corresponding to the modified defect scenario just created.

### Gate Menu

The Gate menu looks much like the Range Menu. The Display Unit toggle button and Start, Stop, Center, and Span buttons (for the gate this time) control values as described in the sections above.

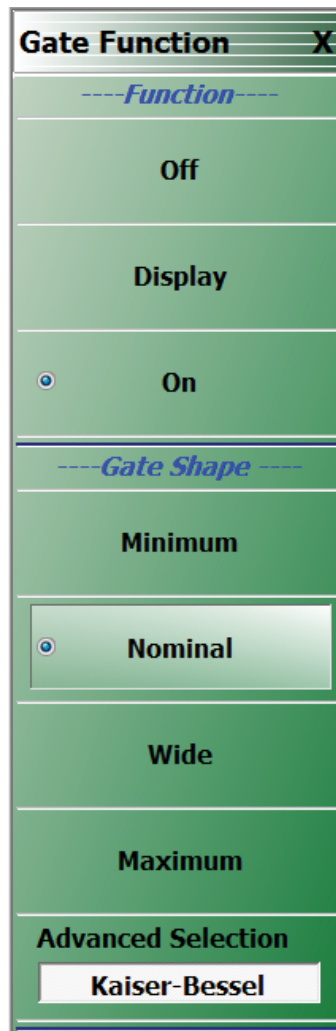


1. Time units (at left)

2. Distance units (at right)

**Figure 12-16.** GATE SETUP Menu

The Notch toggle selects the polarity of the gate. When notch is OFF, the gate will keep everything between start and stop. When notch is ON, the gate will reject everything between start and stop. The main submenu, Gate Function, is shown in [Figure 12-17](#).



**Figure 12-17.** Gate Function Submenu

The default gate shape is nominal. By default, the gate is off. Selecting **Display** will allow the gate function to be drawn on screen (using the current graph type for the active trace). This can be helpful in visualizing what is being included in the gate. Turning gate on will apply the gate to the current time domain data.

The gate shape is analogous to the window selection. If the data was truncated with a sharp gate (minimum, akin to rectangular), maximum resolution is used determining the gate but ripple is introduced in the frequency domain. For more gradual gates, the resolution in separating defects decreases, but the size of the artifacts added to the frequency domain data decreases as well.

The window and gate shapes cannot be selected entirely independently since they interact through the transform. In particular, the use of a very sharp gate with a low side lobe window can lead to large errors. The allowed combinations are shown in the table below. If an invalid combination is selected, the variable not being currently modified will be changed to the nearest valid value.

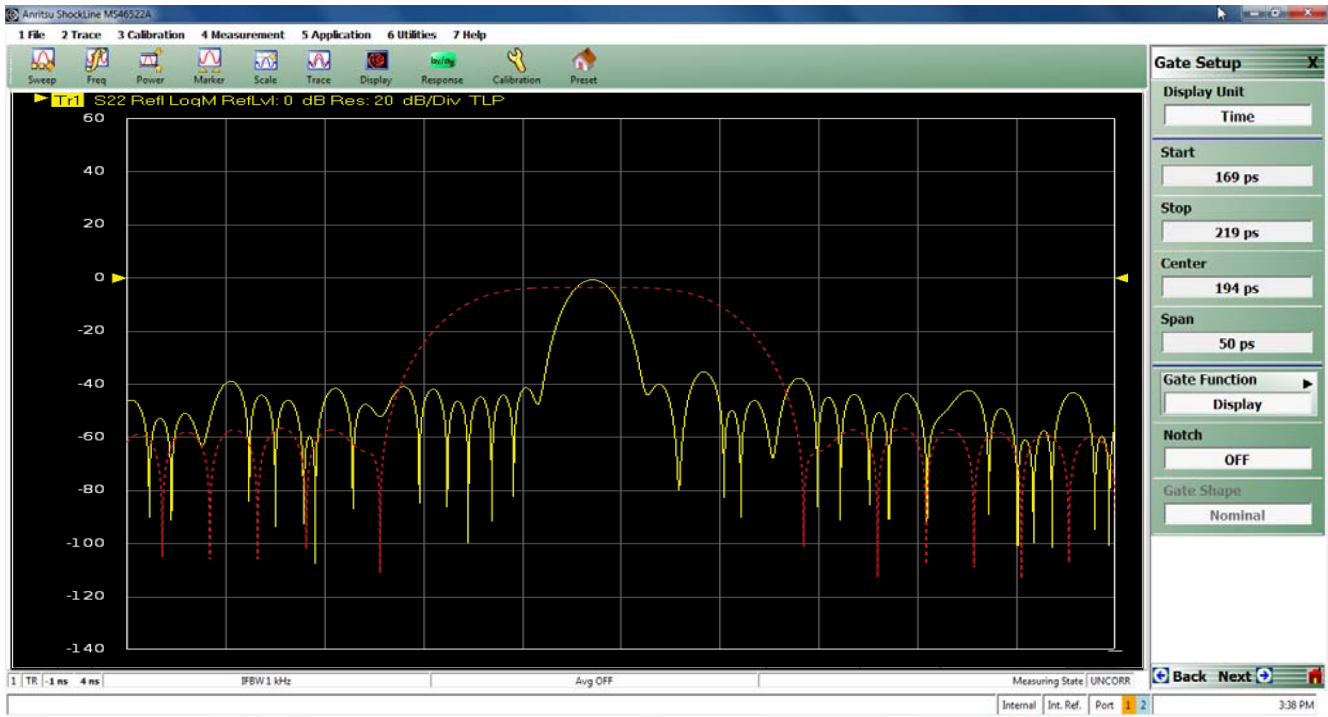
With the advanced gates and windows, selections are not precluded although substantial errors can result if values are chosen without caution. If a more aggressive window is chosen (larger beta or side-lobe level), then the gate must be wider (wide or maximum; larger beta or side-lobe level).

**Table 12-1.** Window Type and Gate Shape Allowed Combinations

Window/Gate	Minimum	Nominal	Wide	Maximum
Rectangular	OK	OK	OK	OK
Nominal	OK	OK	OK	OK
Low side lobe	No	OK	OK	OK
Minimum side lobe	No	No	OK	OK

**DUT Example - Gate and Window Nominal**

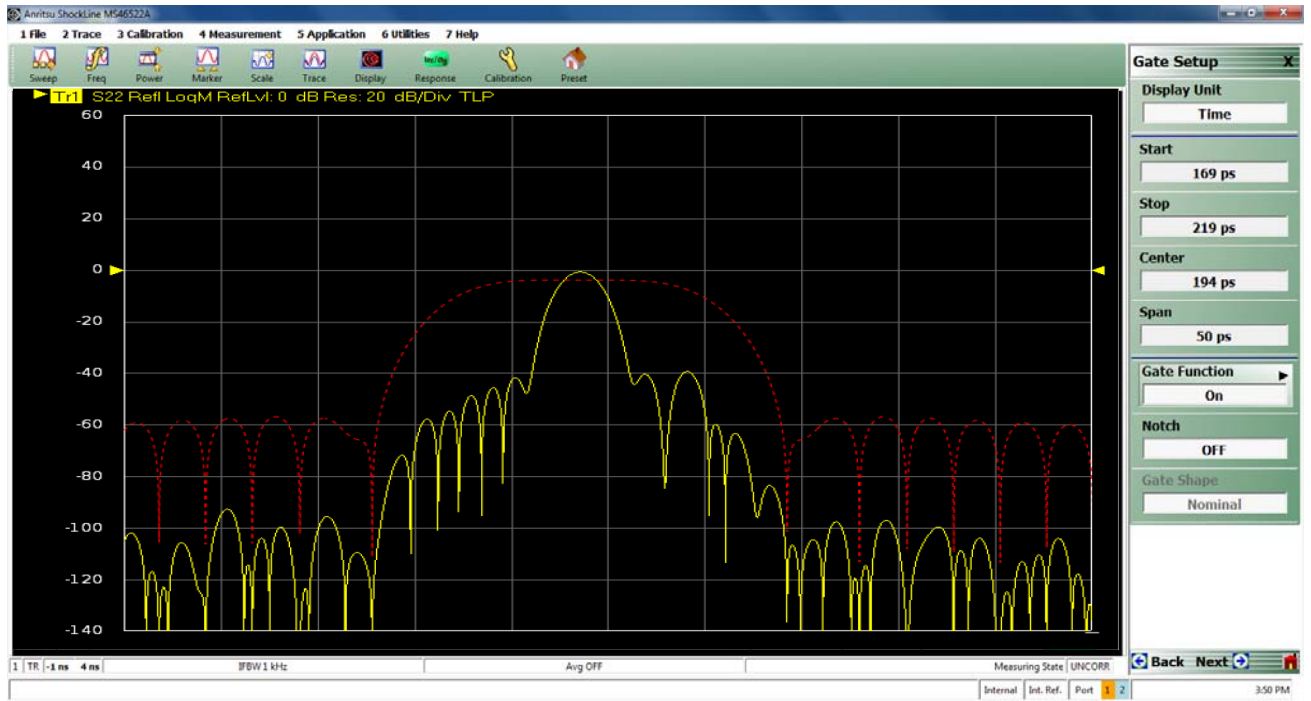
A DUT with a short at the end of a slightly mismatched transmission line is used in this example. The goal is to closely examine the short in frequency domain, with effects of the transmission line excluded. As shown in Figure 12-18, the gate is in display mode surrounding the desired reflection with both gate and window set to nominal.



Gate is the red dashed line

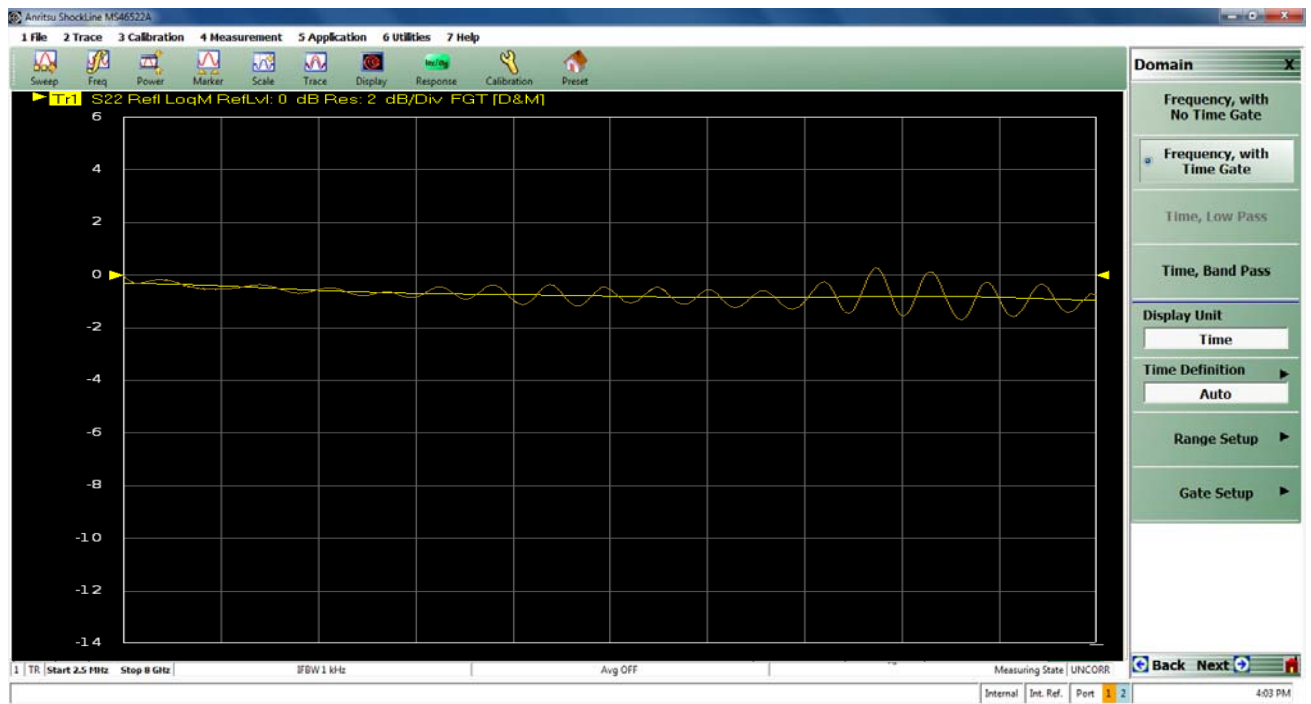
**Figure 12-18.** Gate in Display Mode Example

In the next step, the gate is turned to on, and suppression of the time domain information outside of the gate area is displayed, as shown in [Figure 12-19](#).



**Figure 12-19.** Gate Turned On Example

In the final step, frequency with time gating is activated, removing much of the ripple from the mismatched transmission line and residual source match of the instrument, with the frequency without time gating displayed from memory as a darker trace, as shown in [Figure 12-20](#).



**Figure 12-20.** Frequency with Time Gating Example





# Chapter 13 — Measurement - Advanced Time Domain (Option 22)

## 13-1 Chapter Overview

In its simplest definition, a serial data signal channel has signal integrity when the electrical properties of the channel do not cause data quality degradation and timing errors.

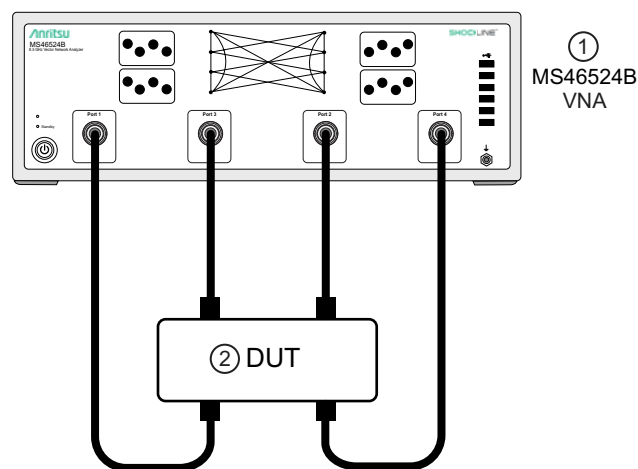
Bit-error-rate testers (BERTs) are often used for functional test of high-speed serial data circuits to determine if signal integrity issues exist. To determine the source of the issues, time domain measurement tools such as oscilloscopes and Time Domain Reflectometers (TDRs) are used.

However, as data rates continue to grow and circuits continue to shrink, the signal channels behave more like complex transmission lines which are more readily characterized by VNAs than by time domain based instruments. For this reason, VNAs are becoming a key instrument for signal integrity (SI) engineers developing and analyzing their serial data channel designs. This chapter will discuss the measurement options available with Advanced Time Domain, setup considerations, and an example of execution procedures.

## 13-2 Introduction

The Advanced Time Domain (ATD) option, Option 22, adds third party measurement functionality to the ShockLine 500B series software to help SI engineers verify and troubleshoot key SI parameters.

The ATD option adds software from AtaiTec™, a premier SI software and consulting firm, and has two basic elements. The first is access to a subset of AtaiTec's Advanced SI Design Kit (ADKmini) software package. The second feature automates the ADK software Plot Eye Diagram function by automatically saving a SnP data file and launching the ADK software to analyze and plot an eye diagram based on the saved data. The ATD option is launched from a software menu in the ShockLine graphical interface.



**Figure 13-1.** 4-Port Setup with Sample 4-Port DUT

## 13-3 Eye Diagram

From the main menu, select the Advanced Time Domain menu. A submenu showing the two ATD options of eye diagram and SI analysis will appear. Select the Eye Diagram.

When the user clicks on the eye diagram menu button the ShockLine software automatically saves an .s4p file on the disk: C:\AnritsuVNA\ADK\_EyeDiagram.s4p

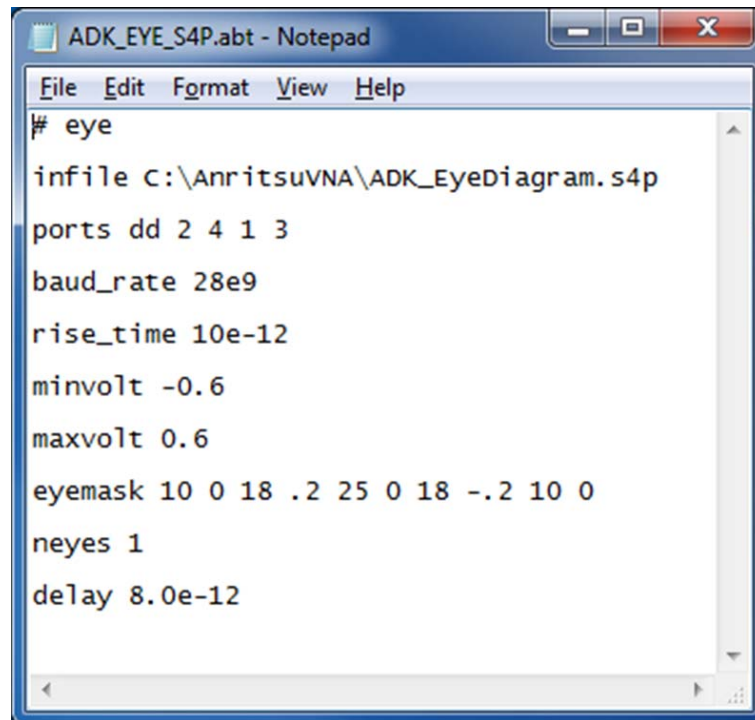
(When using a 2-port MS46522B VNA, the software will automatically store an .s2p file in the same location: C:\AnritsuVNA\ADK\_EyeDiagram.s2p)

### Eye Diagram Configuration File

The ShockLine software uses a batch file (ADK\_EYE.S4P.abt in the C:\AnritsuVNA\ADK folder) to launch the ADKmini eye diagram.

The batch file is a simple text file (Figure 13-2) that has the setup information for the eye diagram. It includes the location of the .s4p file, the port order for the data, baud rate, rise time, and voltage swing for the simulated signal.

The user can also edit the file to change/add setups for the eye diagram. Commands are available from the ADK User's Guide (ADK\_ug.pdf) which is located in the C:\Program Files\AtaiTec\Doc directory on the VNA or can be downloaded from the Anritsu website. The batch file commands for the eye diagram are located in the Batch section of the user guide starting at the "# eye" command. All setups available in the SI analysis tool under "Plot eye diagram" are available as a batch file command.



```
ADK_EYE_S4P.abt - Notepad
File Edit Format View Help
# eye
infile C:\AnritsuVNA\ADK_EyeDiagram.s4p
ports dd 2 4 1 3
baud_rate 28e9
rise_time 10e-12
minvolt -0.6
maxvolt 0.6
eyemask 10 0 18 .2 25 0 18 -.2 10 0
neyes 1
delay 8.0e-12
```

Figure 13-2. Example Eye Diagram Batch File

## Eye Diagram Plot and Calculations

The ADKmini software calculates an eye diagram based on the measured s-parameter data stored in an s4p file on the VNA. The frequency domain data in the s4p file is used to simulate the effect the measured device would have on a digital data stream. The s4p data file is saved when the user selects the eye diagram in the ATD menu so the desired DUT measurement should be completely setup and stable before selecting the eye diagram button. The data output window shows the calculated eye height, eye width, jitter, and delay to the center of the eye. The eye diagram display is configurable and is controlled by the batch file documented above.

A typical output plot and associated data output window are shown in [Figure 13-4](#) and [Figure 13-3](#).

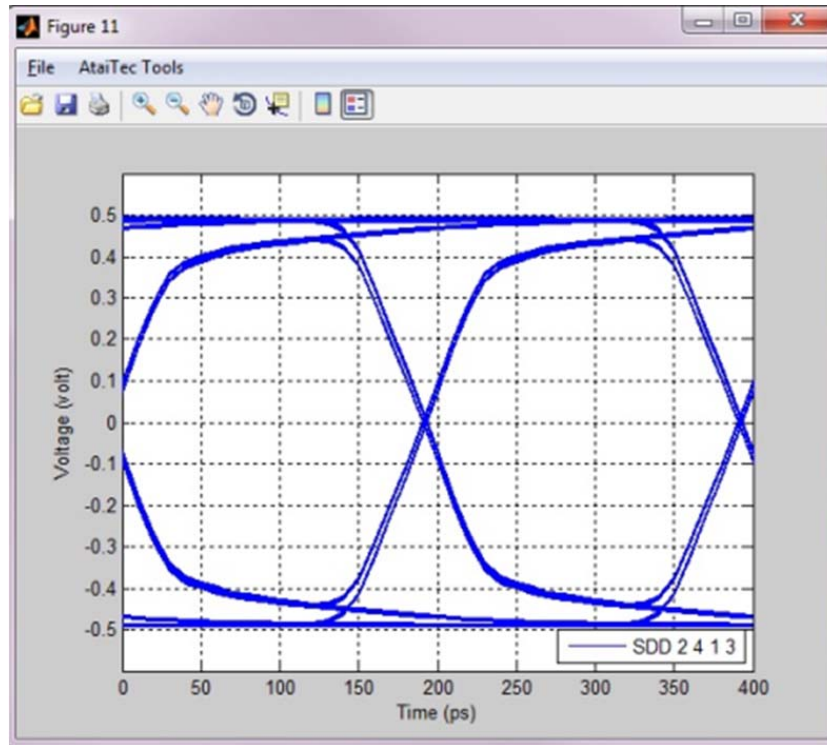
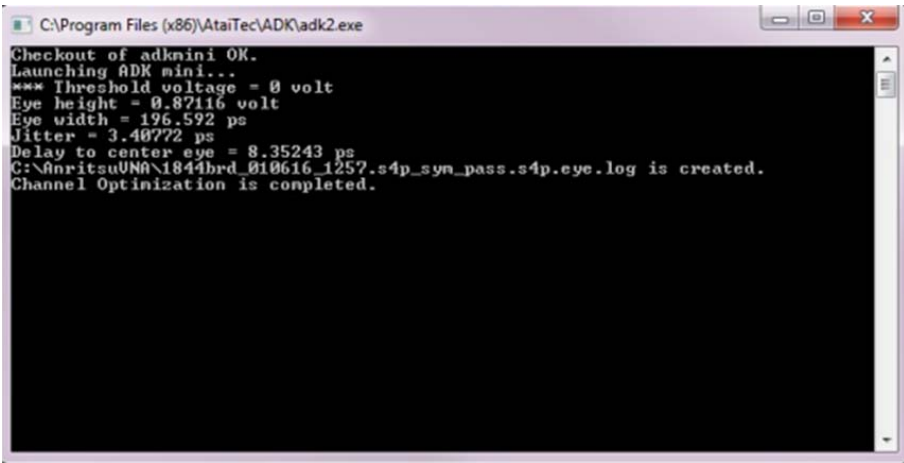


Figure 13-3. ATD Eye Diagram Plot



```
C:\Program Files (x86)\AtaiTec\ADK\adk2.exe
Checkout of adkmini OK.
Launching ADK mini...
*** Threshold voltage = 0 volt
Eye height = 0.87116 volt
Eye width = 196.592 ps
Jitter = 3.40772 ps
Delay to center eye = 8.35243 ps
C:\AnritsuUNA\1844brd_010616_1257.s4p_syn_pass.s4p.eye.log is created.
Channel Optimization is completed.
```

Figure 13-4. ATD Eye Diagram Data Output Window

## 13-4 Launching the SI Analysis Tools (ADK mini)

Clicking on the SI analysis button on the ATD menu launches the ADKmini software. The main menu for this software is shown in [Figure 13-5](#).

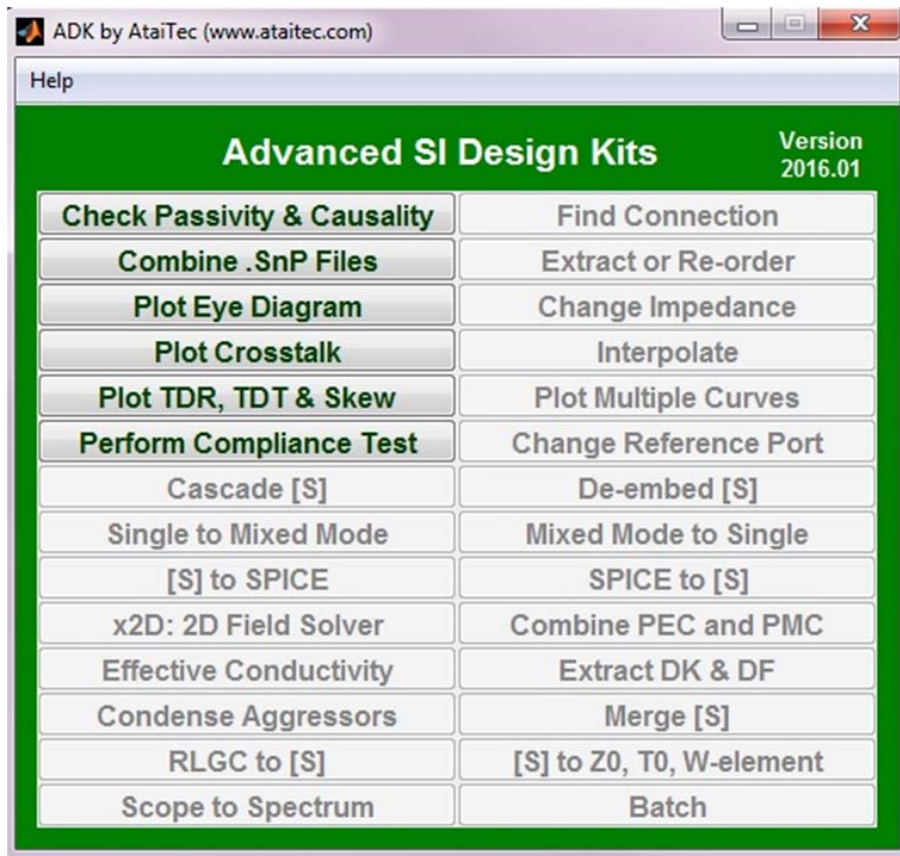


Figure 13-5. ADKmini Main Menu

## 13-5 Overview of the ADKmini Functions

### Check Passivity & Causality

This utility (Figure 13-6) is often used when trying to correlate simulated and measured data. It lets the user check an .SnP file for passivity, causality, and reciprocity, and can add correction to reduce the likelihood of attempted correlation to non-physical data.

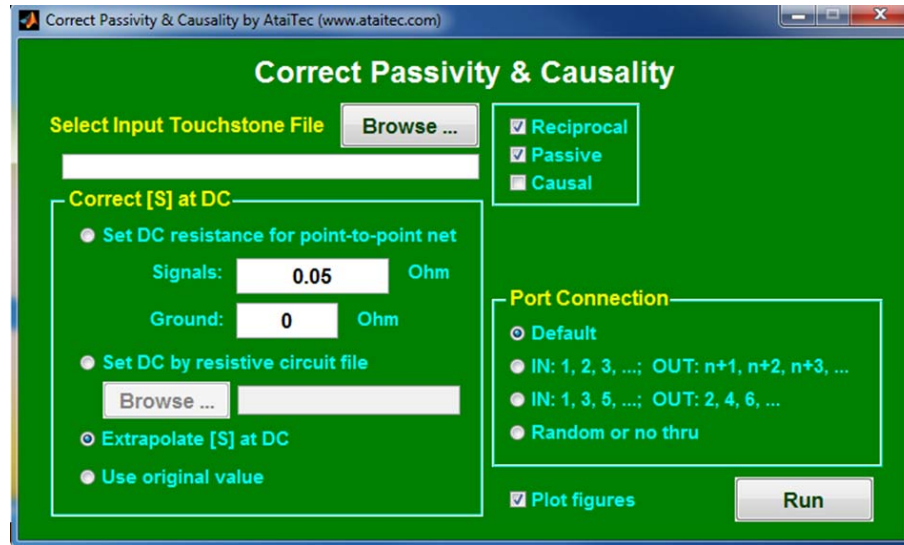


Figure 13-6. Correct Passivity and Causality

## Combine .SnP Files

With this utility (Figure 13-7), the user can combine several Touchstone (.SnP) files and “expand” them into a single file with more ports. Zeros are inserted for un-specified S-parameters. One application is to combine many 4-port measurement files into a larger multi-port file. All .SnP files must be at the same frequencies.

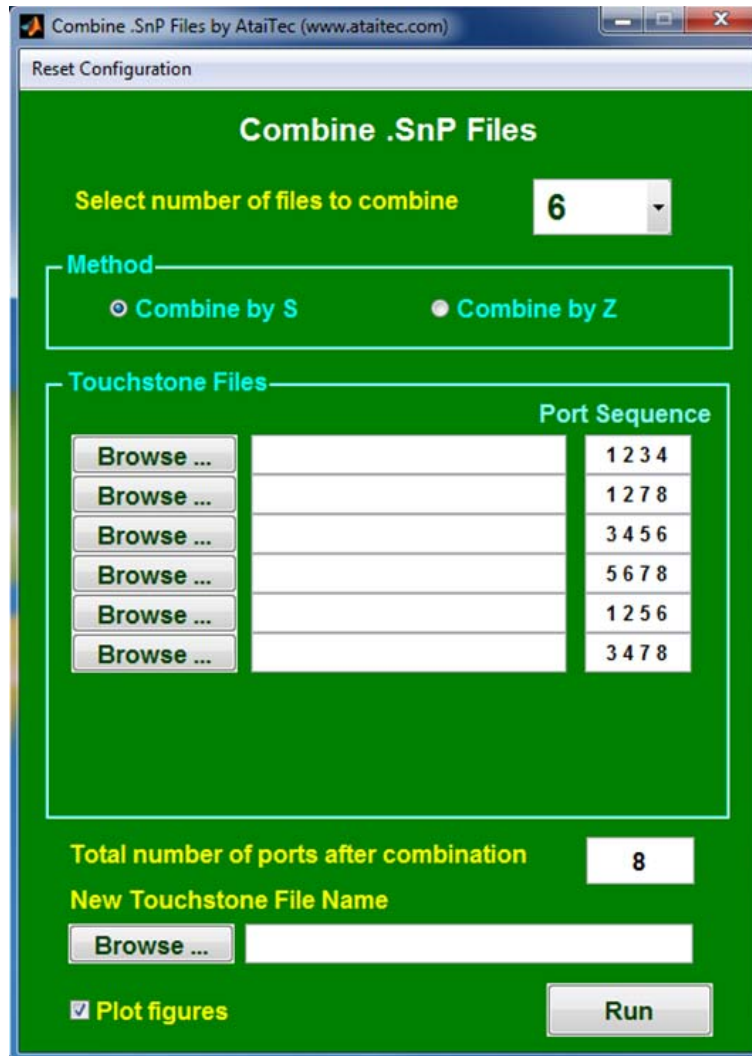


Figure 13-7. Combine .SnP Files Dialog

### Plot Eye Diagram

This is the same utility that is used to plot the eye diagram when the “eye diagram” button is selected in the ATD menu. This utility (Figure 13-8) takes the user imported S-parameter data and simulates the single-ended or mixed-mode bit-by-bit channel response to NRZ or 4-level pulse amplitude modulation (PAM-4) signals. This utility can plot bit waveforms, eye diagram or spectrum simulation data with a pseudo-random bit stream (PRBS) or a fixed data pattern. The user can also apply TX feed forward equalization (FFE), RX continuous time linear equalization (CTLE) and RX decision feedback equalizer (DFE) tap coefficients to the simulation.



Figure 13-8. Plot Eye Diagram Dialog



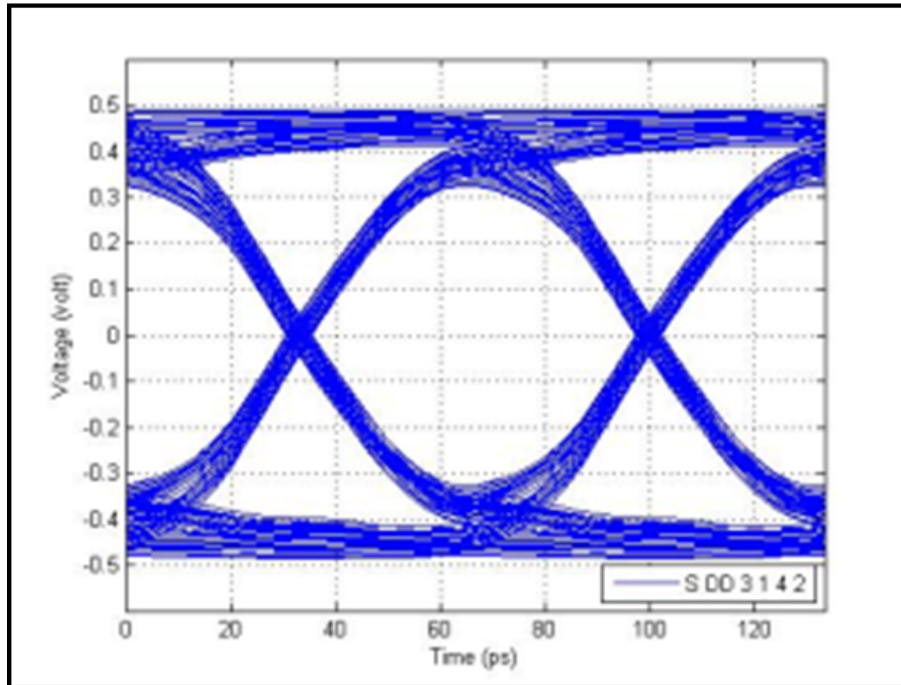


Figure 13-9. Eye Diagram Plot

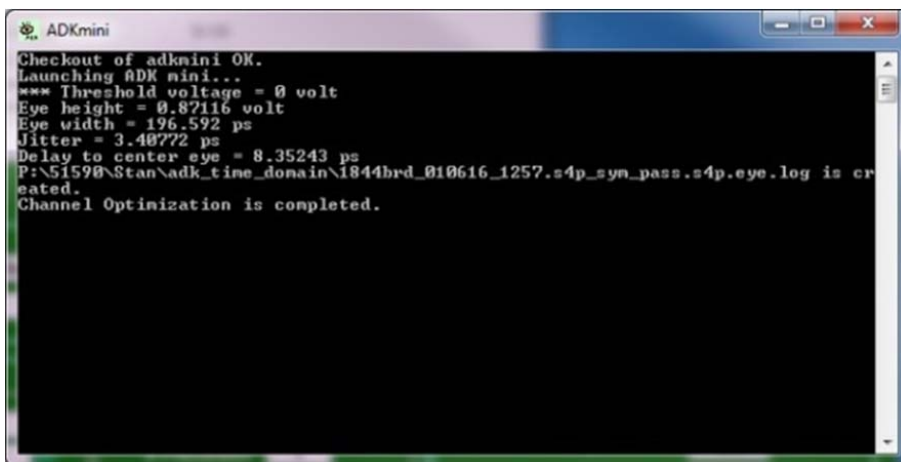


Figure 13-10. ADK Mini Eye Parameters



## Plot Crosstalk

This utility (Figure 13-11) enables the user to plot single-ended or differential near-end crosstalk (NEXT), and far-end crosstalk (FEXT) channel responses. The user selects the port sequence, single-ended or differential crosstalk, Victim, NEXT and FEXT port configurations to setup the utility.

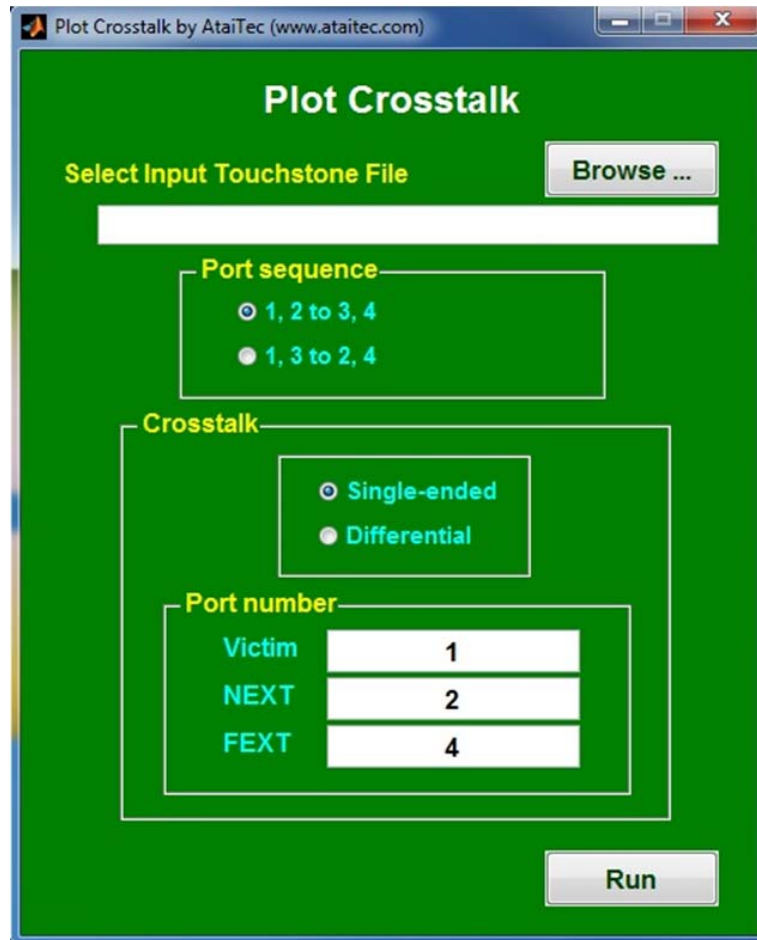


Figure 13-11. Plot Crosstalk Dialog

## Plot TDR, TDT & Skew

This utility (Figure 13-12) converts S-parameter data into an impedance profile, a time domain reflection (TDR) with an open end, or a TDR/time domain transmission (TDT) with matched terminations. The user can select step, single-bit, or impulse responses. Resulting TDR, TDT, and skew can be plotted.

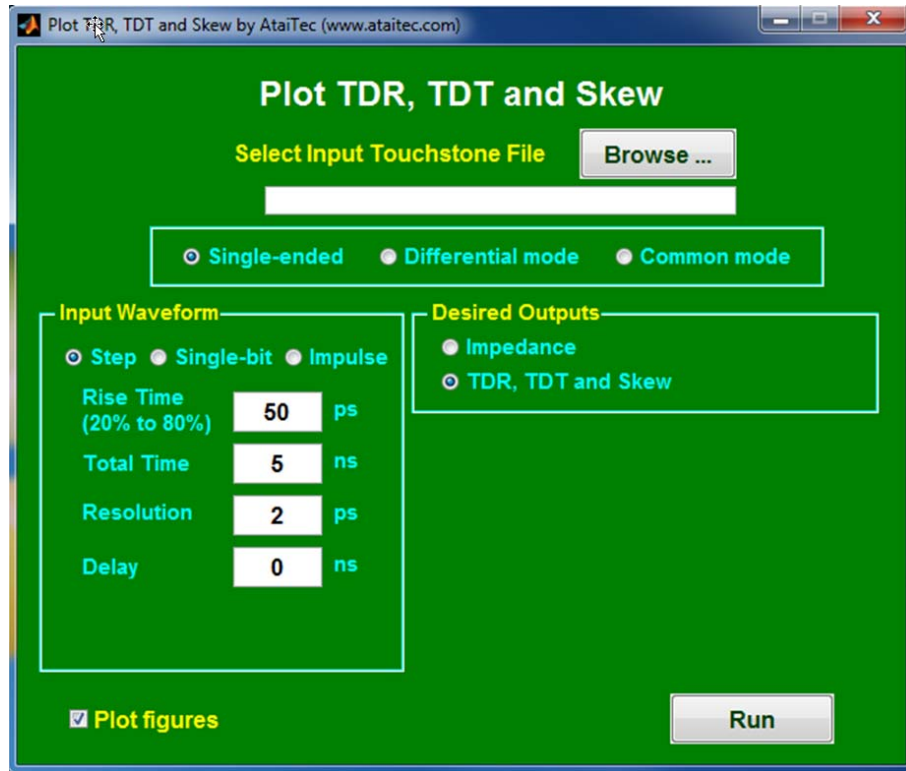


Figure 13-12. Plot TDR, TDT & Skew Dialog

### Perform Compliance Test

With this utility (Figure 13-13), the user can choose among several IEEE and OIF specs, and compare the power sum of coupled noises, insertion loss crosstalk ratio (ICR), insertion loss, insertion loss deviation (ILD), and integrated crosstalk noise (ICN), etc.

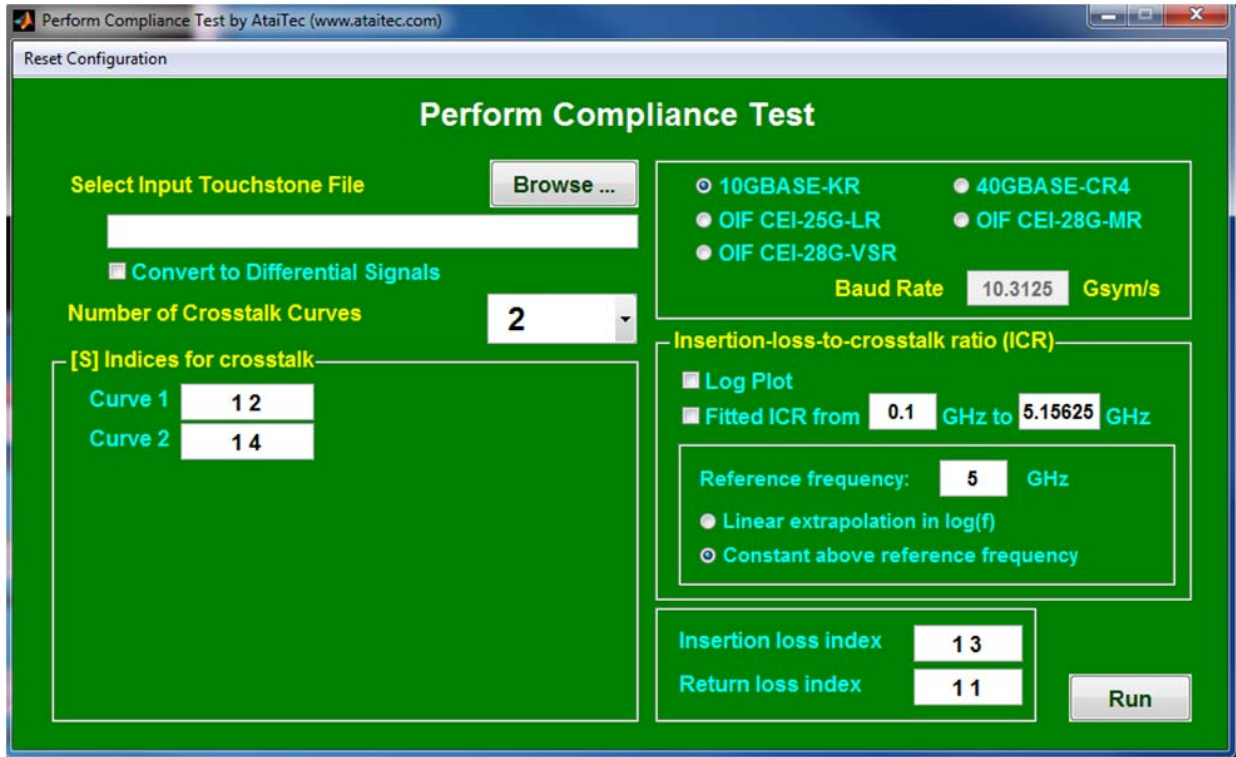


Figure 13-13. Perform Compliance Test Dialog

## 13-6 Example Measurement

For this example, we calibrate the VNA with a harmonic calibration. This makes the start frequency equal to the step size allowing the extrapolation of data to DC. For more information about calibrating this setup, please see the MS46522B or MS46524B demonstration guides that detail step by step instructions for this calibration setup.

- Start frequency = 40 MHz
- Stop Frequency = 40 GHz
- Number of points = 1000
- The VNA will be measuring the 100 ohm differential trace.

The setup file should be displaying differential s-parameters SD1D1, SD1D2, SD2D1 and SD2D2 as shown in Figure 13-14.

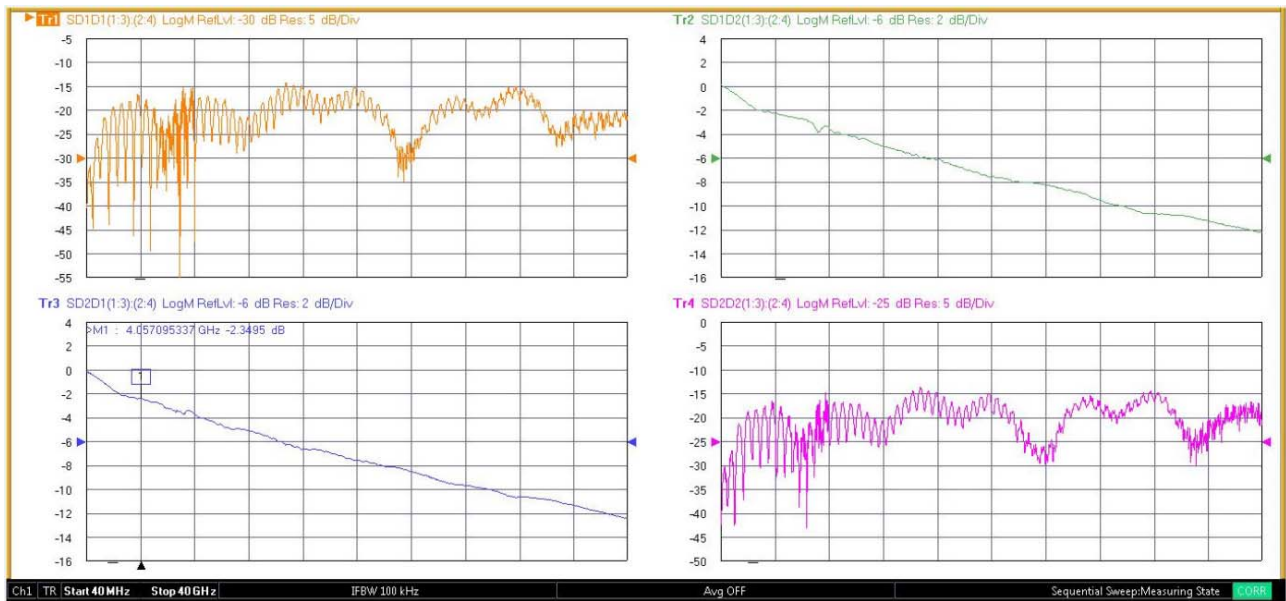


Figure 13-14. Differential S-Parameters

## 13-7 Summary

The ATD option, Option 22, provides tools for SI analysis on the performance series of ShockLine VNAs (MS46522B/MS46524B). It is well suited for SI engineers who may be building circuit models and taking measurements to validate them and/or troubleshooting SI issues. It includes a subset of popular SI tools, including the ability to plot eye diagrams, determine NEXT and FEXT, and apply various equalization techniques. When a more extensive set of SI tools are required, Anritsu customers can purchase the AtaiTec ADK software.

## 13-8 Signal Integrity Acronyms

Acronym	Definition
<b>ADK</b>	AtaiTec's Advanced SI Design Kit
<b>ADKmini</b>	A subset of ADK incorporated into the ShockLine Advanced Time Domain option (Opt 22)
<b>ATD</b>	ShockLine Advanced Time Domain option (Opt 22)
<b>BERT</b>	Bit-Error-Rate Tester
<b>CTLE</b>	Continuous Time Linear Equalization
<b>DFE</b>	Decision Feedback Equalizer
<b>FEXT</b>	Far-End Crosstalk
<b>FFE</b>	Feed Forward Equalization
<b>ICN</b>	Integrated Crosstalk Noise
<b>ICR</b>	Insertion loss Crosstalk Ratio
<b>ILD</b>	Insertion Loss Deviation
<b>MOI</b>	Method Of Implementation
<b>NEXT</b>	Near-End Crosstalk
<b>NRZ</b>	Non-Return-to-Zero
<b>OIF</b>	Optical Internet working Forum
<b>PAM-4</b>	4-level Pulse Amplitude Modulation
<b>PLTS</b>	Physical Layer Test System
<b>PRBS</b>	Pseudo-Random Bit Stream
<b>SI</b>	Signal Integrity
<b>.SnP</b>	Touchstone Formatted File of N Ports
<b>TDR</b>	Time Domain Reflectometer -or- Time Domain Reflection
<b>TDT</b>	Time Domain Transmission



# Chapter 14 — Measurement - Sweep Types

## 14-1 Chapter Overview

This chapter covers the different sweep types available with the ShockLine™ ShockLine MS46500B Performance Series VNAs to increase measurement functionality.

## 14-2 Introduction

### Sweep Configuration

Standard sweeps are available on all ShockLine MS46522B and MS46524B VNAs. Simultaneous sweep is only available on MS46522B and MS46524B VNAs with option 10. The MS46522B and MS46524B have independent source for each port.

- Standard Sweep uses one source at a time to make measurements sequentially.
- Simultaneous Sweep automatically programs each port enabling all ports to be measured in parallel. Simultaneous sweep requires a start frequency of 10 MHz or greater.

### Sweep Types

A number of different sweep types are available within the MS46500B Performance Series VNAs including:

- Traditional frequency sweep (defined by a start frequency, a stop frequency and a number of points)
- Log sweep (with a constant ratio or logarithmic step size)
- Power sweep (frequency is constant and power is defined by a start value, a stop value, and a number of power points)
- Frequency-based segmented sweep (frequencies are defined individually or in sub-spans, that are monotonically increasing)
- Index-based segmented sweep (frequencies are defined individually or in sub-spans and can be in any order; all plotting is in terms of index rather than frequency because of the possible direction changes)

The setup complexities in regular frequency sweep and power sweep are minimal and will only be discussed briefly. The segmented sweep possibilities are considerably larger and some explanation will help in setting them up. The SWEEP SETUP and SWEEP TYPES menus are shown in [Figure 14-1](#).

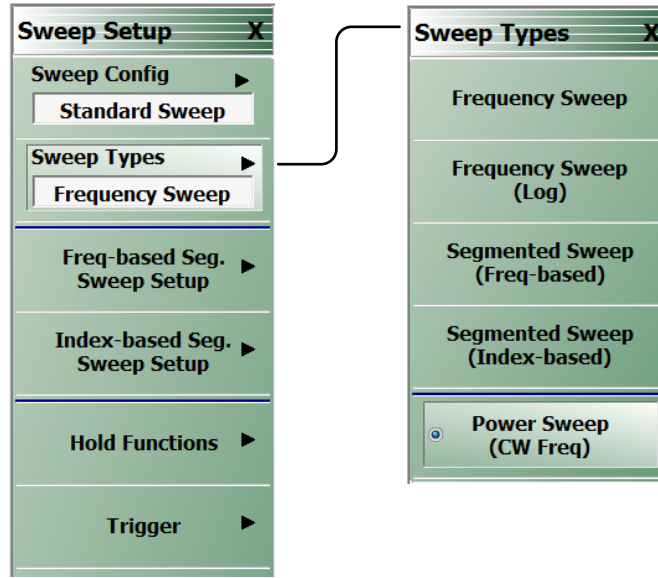


Figure 14-1. SWEEP SETUP Menu

### 14-3 Setting Up Traditional Frequency Sweeps (Linear and Log)

A traditional frequency sweep is based on a start frequency, a stop frequency, and a number of points (or, alternatively, substitute center/span for start/stop). The number of points is not confined to certain preset values. The minimum number is two (otherwise CW mode) and the maximum number is usually 20,001.

Power entry while in frequency mode is accomplished through the Main Power Menu for frequency sweep. [Figure 14-2](#).

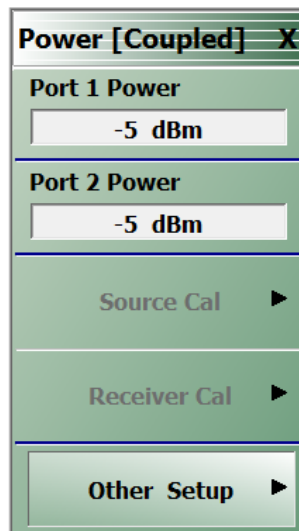
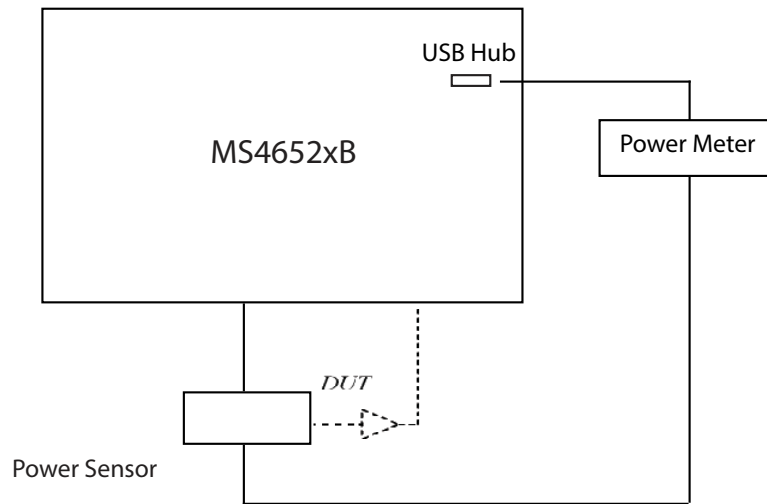


Figure 14-2. Main POWER Menu - Port 1 and Port 2 Coupled



The objective of the power cal is to improve the accuracy of the power delivered to the DUT beyond that provided by the factory ALC calibration (0.1 dB vs. on the order of 1 dB). This is particularly useful if a preamplifier or other network is needed between the test port and the DUT. The exact loss/gain of that network over frequency can be corrected for with reasonable precision. A common setup for executing this calibration is shown in [Figure 14-3](#).



**Figure 14-3.** Power Calibration Setup

The relationship between the power entry fields and the Target Power field of the power calibration is important. First a few definitions:

### ALC Entry Field

Where the requested power is entered on the main Power menu for Port 1, Port 2, etc.

### Effective Power Field

The read-only fields below the ALC entry fields. These play a role when power calibrations are active.

### Target Power Field:

The entry area on the Power Cal submenu where the objective of the power calibration is entered. The normal procedure is to enter the desired power at the user reference plane (where the power sensor will be connected for the power calibration). If the gain/loss between the VNA port and the user reference plane is small, the ALC entry field can be set to the same value as the Target Power. If the gain/loss is significant, the ALC field should be offset by an estimate of that gain/loss (ALC entry field should be higher if it is a loss, and lower if it is a gain). This offset need not be extremely accurate; it serves to inform the system of where roughly to set the internal sources in order to achieve the desired user reference plane power. After the power calibration is completed, the Effective power field will match the Target power. If the ALC entry field is later changed (from the value at the time of the calibration), the Effective power field will also change to reflect an estimate of the new user reference plane power. This new value is only an estimate since the calibration was not performed at that power level and the accuracy will decrease as the change from the calibrated level increases.

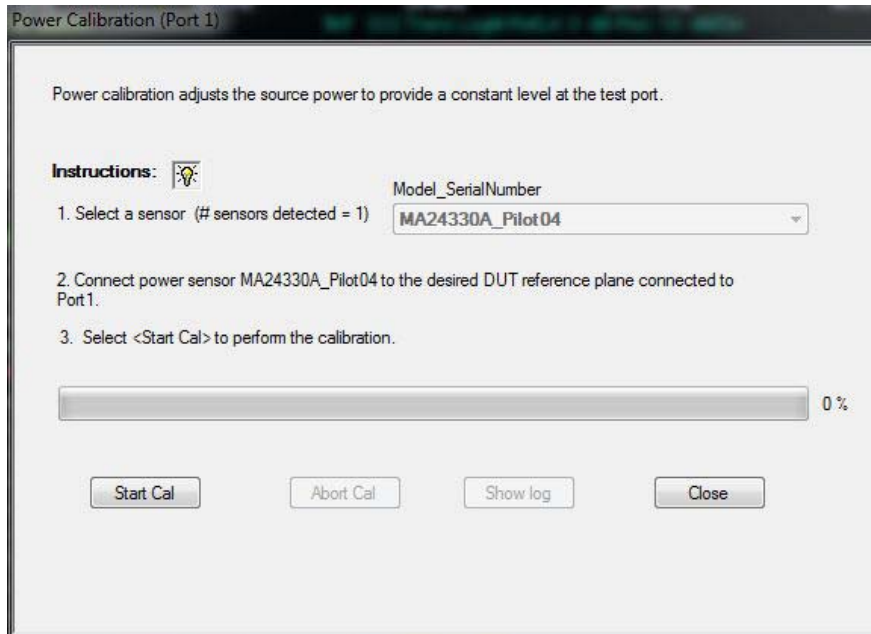
### Example

Target power is  $-20$  dBm and there is about 8 dB of loss from the VNA port to the desired reference plane.

1. Set Target Power to  $-20$  dBm and set the ALC entry field (for that port) to  $-12$  dBm. Perform the power calibration.

2. After the calibration is successfully completed, the Effective power will read  $-20$  dBm and the ALC entry field will remain at  $-12$  dBm.
3. Change the ALC entry field to  $-15$  dBm. The Effective power field will change to  $-23$  dBm (the estimate of the new power at the reference plane).
4. Turn the power calibration off. If the ALC entry field is still at  $-15$  dBm, the Effective power field will change to also be at  $-15$  dBm. With the power calibration no longer applied, the system's best estimate of the power being applied is that based on the internal power calibration. Since the power cal performs the calibration at every point, this calibration can be time-consuming (particularly if a slower thermal power sensor is being used). One should exercise some restraint when selecting the number of power points if this time delay will be an issue. Details of power sensor connection and setup are covered in the Operation Manual. The dialog that appears when executing this calibration is shown in [Figure 14-4](#).

**Note** Level control is done through ALC control in normal source mode for all frequency models. In multiple source control mode ALC control is only available below 8.5 GHz. Power calibration for multiple source control mode above 8.5 GHz is done in an open loop configuration.



**Figure 14-4.** POWER CALIBRATION (PORT 1) Dialog Box

## 14-4 Setting Up Power Sweeps

A power sweep is valuable for making power dependent semi-linear measurements. The frequency is set at a single CW value and the power range is specified in a way analogous to frequency sweeps as suggested by [Figure 14-5](#).

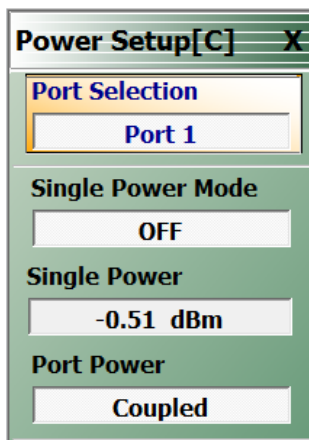


**Figure 14-5.** Main Power Sweep Menu - POWER [COUPLED] Menu

As with the regular power control in frequency sweep, the power at the two ports may be coupled or uncoupled. This feature takes on new importance in power sweep in that the two ports may drive with completely different power ramps. The number of points in these two power sweeps must, however, be the same.

Power offset is an important entry for cases when an external preamplifier, large pad, or other network may be in use between the port and the DUT plane. By entering a value here to approximate the net gain of the external networks, the effective power fields will be updated accordingly and any power calibrations performed will be more efficient.

Some of the more detailed controls are on the power setup level of the power menu located on the POWER SETUP menu (see [Figure 14-6](#)). The coupling control and port selection (when uncoupled, duplicate of first level) is located here as is the single power selection items. This entry allows one to put the system in constant power (and constant frequency) and is often used for making DUT adjustments prior to full power sweep measurements.



**Figure 14-6.** Second Level Power Sweep Setup Menu - POWER SETUP[C] Menu

## 14-5 Frequency-Based Segmented Sweep

In many applications, having a simple list of frequencies where the step size between points is uniform is not adequate. The DUT specifications may have specifications in certain bands and certain specific frequencies that must be tested, there may be certain communications bands that must be tested, or there may be certain spot frequencies that are of interest for troubleshooting or analysis.

For these cases and others, segmented sweep allows one to put together a very arbitrary list of frequencies to sweep as well as having some control of instrument behavior that is distinct at these different points and/or segments. The entire sweep is broken into segments (a segment may contain one or many points) and in each segment, one can independently control

- IF bandwidth
- Averaging
- Port 1 Power and Port 2 Power
- Port 3 Power and Port 4 Power (MS46524B only)

There is a distinction made between frequency-based and index-based segmented sweep that should be explained:

- **Frequency-Based**

Frequency is always monotonically increasing (within a segment and between segments). Plotting may be based on the frequency or the index of the particular point (more on this later).

- **Index-Based**

The segments do not have to be in any order with regards to frequency. Plotting is always based on the point index.

Frequency-based is most commonly used and will be discussed in this section. Index-based sweeps, which is used when reverse sweeps and particular frequency order is important, is covered in the next section.

The main menu and an example entry table are shown in [Figure 14-7](#) and [Figure 14-8 on page 14-8](#). The main purpose of this menu is to aid entering data into the table and to help save and recall that data. Note that segmented sweep tables can be saved/recalled separately from this menu or they can be saved/recalled as part of the global setup using the entries under the File menu.

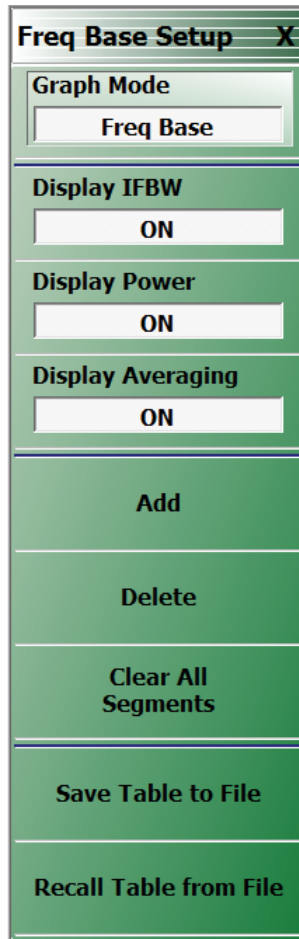


Figure 14-7. FREQ BASE SETUP (FREQUENCY-BASED SETUP) Menu

0 Hz [Up] [Down] [Enter]

	Seg. On	Freq Def. for F1 & F2	F1	F2	# of Pts
▶ 1	<input checked="" type="checkbox"/>	Start & Stop	300 kHz	8.5 GHz	15

Step/Stop Freq	IFBW	P1 Src Pwr	P2 Src Pwr	Averaging
607.1214285...	100 kHz	0	0	1

Figure 14-8. Tableau Entry Table for Frequency-based Segmented Sweep

The table will start with one segment and the start, stop and number of points must be defined. The pull-down item in Column 3 allows an alternatively specified start and step or a CW frequency. The step or stop frequency (which depends on the pull-down selection) will appear as a read-only field in Column 7. The IFBW, power and averaging columns can be enabled on the setup menu and entered separately by segment. The current source attenuator setting will appear in the column header and may not be changed by segment (will read 0 dB if the attenuators are not installed). If the display of these fields is not enabled, the values for those variables set in regular frequency sweep mode will prevail for all segments.

The Add, Delete, and Clear All functions are obvious. The delete function applies to the current row as indicated by the caret in column 1.

As with the multiple source tables, there are two ways to enter numbers

- Click on the cell and the text entry box above the table becomes active.
- Click twice on the cell and type directly into the cell. Frequency units must be entered and must have a space between the number and the units.

If an invalid number is entered in any field, the system will change the value to the nearest valid entry.

The one remaining item on the setup menu for frequency-based segmented sweep is graph mode, which controls how the x-axis is setup for all plotting activities but does not affect the sweep itself. In Frequency-based graph mode, the x-axis will be in frequency and all segments will be plotted where those frequencies lie. While correct, this can lead to an odd-looking display if the segments are disjointed as shown in Figure 14-9.

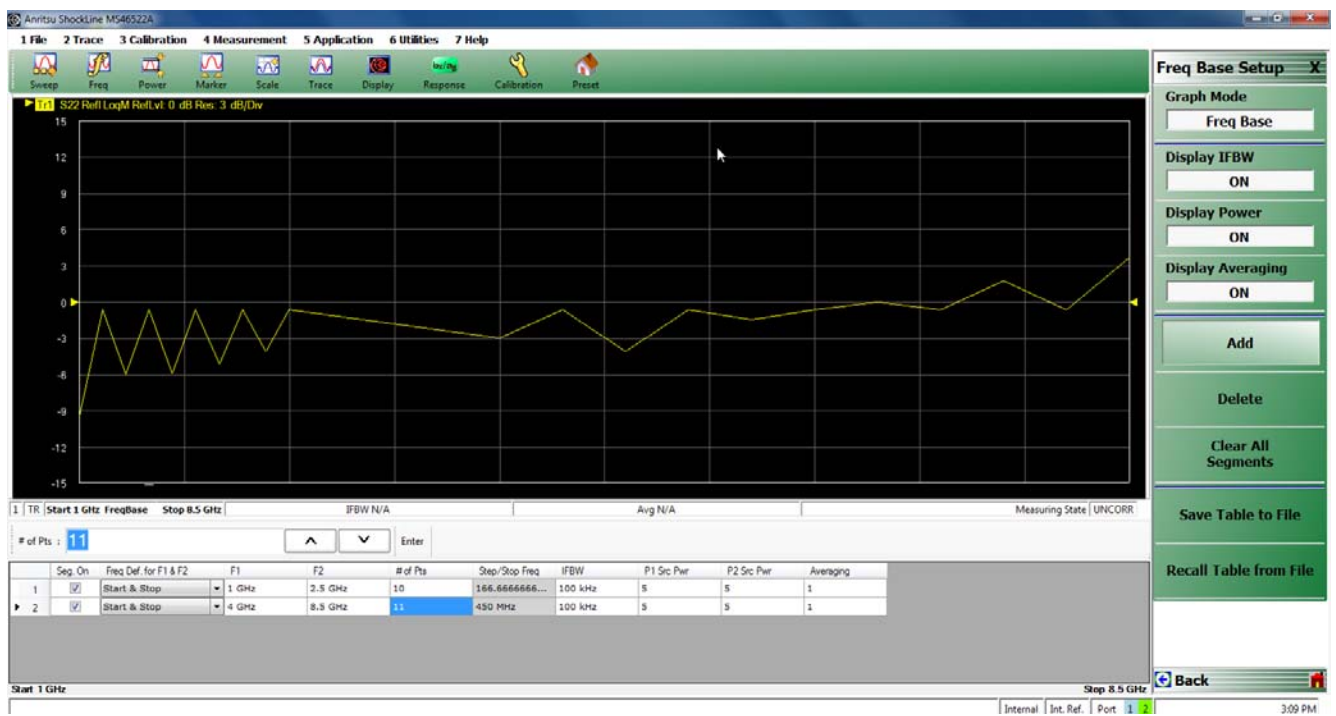


Figure 14-9. Frequency-Based Graph Mode

Since Segment 1 covers 1 GHz to 2.5 GHz and Segment 2 covers 2.5 GHz to 8.5 GHz, there is a gap in frequency where no measurements are made. For the purposes of plotting in this graph mode, the two areas are connected by a single line segment. Note that the point spacing in the plot precisely matches the frequency spacing.

When all of the data points plotted without regard to proportional frequency separation are required. For these occasions, the Index-based graph mode is available and an example is in Figure 14-10 for the same setup as Figure 14-9. Here, the x-axis is point index so all plotted points are equally spaced in the x-direction and the frequency based segmented sweep is disjointed.

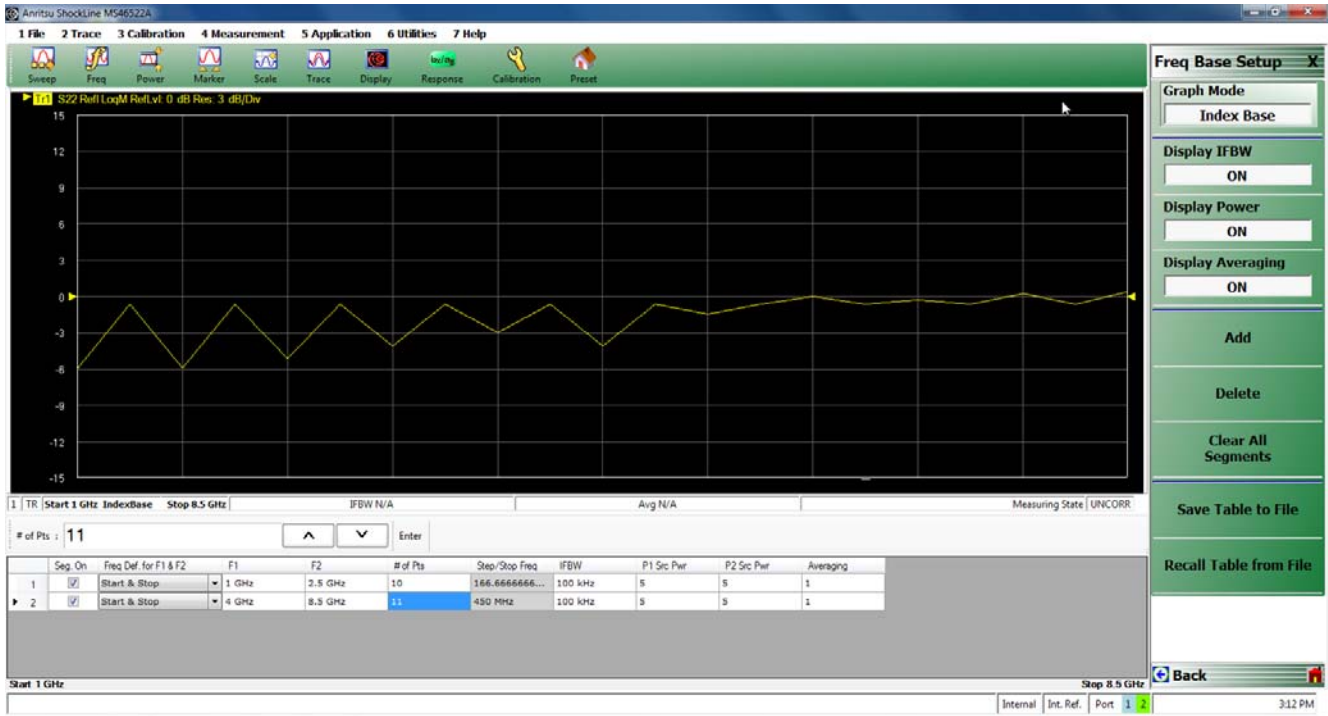


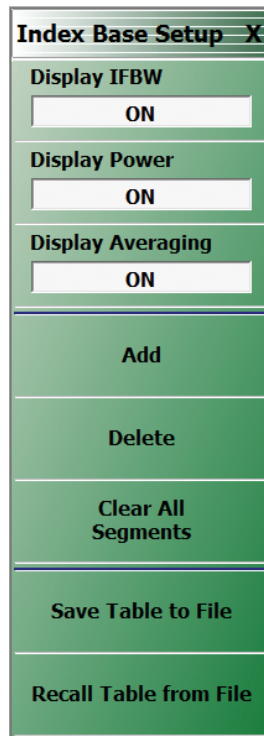
Figure 14-10. Index-Base Graph Mode

It is important to keep separate the concepts of frequency-based versus index-based for the graph mode (which only controls how things are plotted) and frequency-based versus index-based segmented sweep type (which determines how the points are swept by the instrument hardware).



## 14-6 Index-Based Segmented Sweep

In index-based segmented sweep the frequency segments may be in any order. This may be useful for particular test patterns where reverse sweeps are needed or particular frequencies must be measured before others due to DUT hysteresis. The setup menu and an example table are in [Figure 14-11](#) and [Figure 14-12](#).



**Figure 14-11.** Main Menu for Index-based Segmented Sweep - INDEX BASE SETUP Menu

All plotting in this sweep type is based on the point index, which is listed in the last column of the table below.

The screenshot shows a software interface for setting up a segmented sweep. At the top, there is a field for "F1" set to "300.000 kHz" with up and down arrow buttons and units "GHz" and "MHz". Below this is a table with columns: "Seg. On", "Freq Def. for F1 & F2", "F1", "F2", and "# of Pts".

	Seg. On	Freq Def. for F1 & F2	F1	F2	# of Pts
▶ 1	<input checked="" type="checkbox"/>	Start & Stop	300 kHz	3.5 GHz	15
2	<input checked="" type="checkbox"/>	Start & Stop	4.50000001 G...	8.5 GHz	2
3	<input checked="" type="checkbox"/>	Start & Stop	10.50000003 ...	30.50000004 ...	2

Below this table is a detailed "Tableau Entry Table" with columns: "Step/Stop Freq", "IFBW", "P1 Src Pwr", "P2 Src Pwr", "Averaging", and "Index Range".

Step/Stop Freq	IFBW	P1 Src Pwr	P2 Src Pwr	Averaging	Index Range
249.9785714...	100 kHz	5	5	1	0-14
3.99999999 G...	100 kHz	5	5	1	15-16
20.00000001 ...	100 kHz	5	5	1	17-18

**Figure 14-12.** Tableau Entry Table for Index-based Segmented Sweep

Aside from the increased flexibility in ordering, there are few other differences relative to frequency-based segmented sweep. One exception is that there is now no choice of graph mode; it will always be index-based. In this case, it is to avoid confusing and unreadable displays where one could have many reverse tracing operations.



# Chapter 15 — Reciprocal Measurements

## 15-1 Chapter Overview

This chapter describes the reciprocal concept (SOLR or unknown thru approach) measurements.

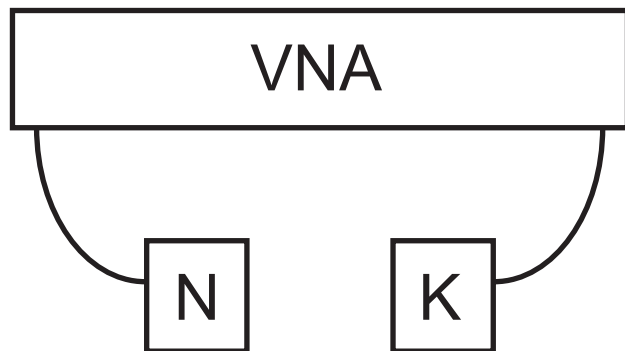
## 15-2 Introduction

The previously discussed SOLT and offset short calibration techniques all require a known “thru (or through)” as part of the full 2 port (or 1p-2p) calibration. The “thru” is really a defined transmission line having known length, known loss, and assumed perfect match (under most conditions). There are certain cases when this is not possible:

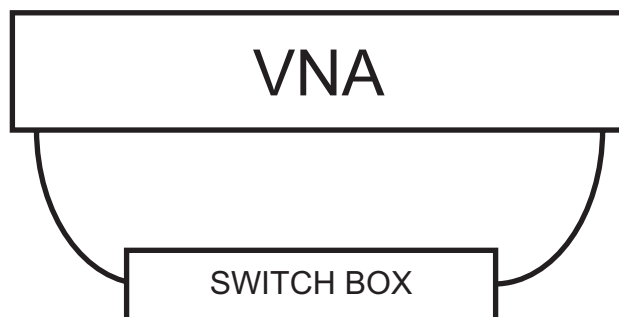
- Coaxial cal when the two ports are different connector types
- On-wafer when the “thru” is a meandering transmission line of imperfect match
- A calibration that must take place through a test set (coax or waveguide) with unknown (and highly frequency dependent) loss and match



Bent thru line in CPW



Calibration with two different connector types



Calibration through a switch box or other network

**Figure 15-1.** Illustration of SOLR or “Unknown Thru” Calibration

For these cases, and others when the “thru” cannot be very well-known, there is the Reciprocal option (also known as the unknown thru). In this case, the same reflect standards are used, but no assumption is made about the “thru” except that it be reciprocal (i.e.,  $S_{21}=S_{12}$ ; no assumption made about  $S_{11}$  and  $S_{22}$ ). In practice, there are some limits to this.

The technique borrows from the LRL family and uses some of the redundancy available with the fully-defined families to reduce knowledge needed about something (the thru in this case). The resulting cal will generally not be quite as accurate as the regular thru version if the thru met the conditions described above. It will, however, be better than using the regular thru version when the thru has unknown loss or match.

## 15-3 Line Length Estimate

A line length estimate (electrical delay or free space equivalent length) can be used to help with root choice, but this is not a critical parameter. Typically, one needs only to be within a half-wavelength of the correct length at the maximum desired calibration frequency. If one enters 0 for the length, the software will automatically estimate the length based on fitting-to-the-phase function at the lower part of the frequency range. Details are discussed in [Chapter 10, “Calibration and Measurement Enhancements”](#) related to automatic length estimation for adapter removal procedures and the same principles apply here. The only danger in auto length estimation is if the frequency step size is large relative to the electrical size of the setup. As discussed in [Chapter 10, “Calibration and Measurement Enhancements”](#), one can look at the phase of an uncalibrated transmission parameter in the setup to see how fast the phase is changing.

If the match of the reciprocal network is worse than  $-8$  dB or the loss exceeds  $\sim 20$  dB, the reciprocal treatment will start to degrade, but a calibration will still be possible. Since such a network is at the limits of de-embedding capability, there are few choices except to consider 1p-2p processing with scalar de-embedding.

## 15-4 SOLR Calibration

For SOLR, the “select line” field would be chosen as “reciprocal” instead of “through” and the length field would be the estimate of length for root choice that was discussed above (see [Figure 15-2](#)). Note that the same variants are possible for offset short and triple offset short calibrations.

The screenshot shows a dialog box for setting up a two-port calibration. The main area is divided into sections for Test Port 1 and Test Port 2, and a right-hand sidebar for line and loss parameters.

- Ref Impedance ( $\Omega$ ):** 50.000
- Select Cal Type:**
  - Full 2 Port
  - 1 Path 2 Port (1 $\rightarrow$ 2)
  - 1 Path 2 Port (2 $\rightarrow$ 1)
- Load Type:**
  - Broadband Load
  - Sliding Load
- Test Port 1 (N-Conn(F)):**
  - Cal Kit: TOSLN50A (with Standard Info button)
  - Select BB Load:  Load 1  Load 2 (with Load Cal Kit button)
- Test Port 2 (N-Conn(F)):**
  - Cal Kit: TOSLN50A (with Standard Info button)
  - Select BB Load:  Load 1  Load 2 (with Load Cal Kit button)
- Through/ Reciprocal:**
  - Select Line: Through
  - Length (mm): 58.5000
  - Line Impedance ( $\Omega$ ): 50.000
  - Use S2P for Thru
  - Line Loss (dB/mm): 0.0000
  - @ Frequency (GHz): 0.0000

Buttons for OK and Cancel are at the bottom.

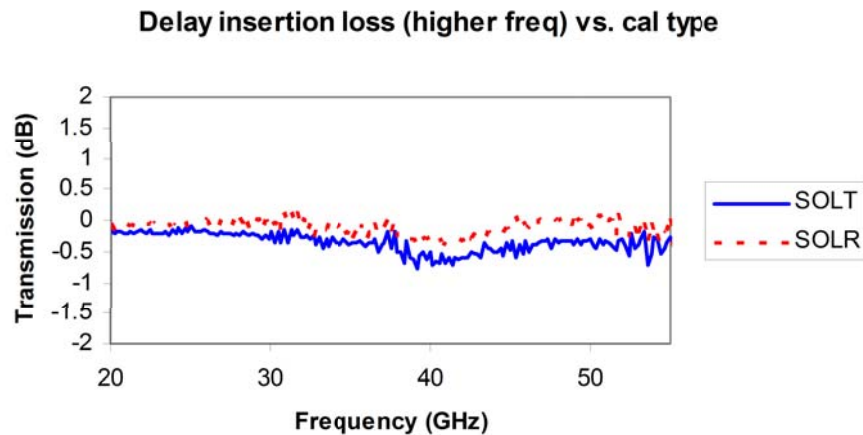
Typical calibration setup dialog for SOLR (Short-Open-Load-Reflection)

**Figure 15-2.** TWO PORT CAL SETUP (SOLT/R, COAX) Dialog Box

## 15-5 Uncertainty and Sensitivity Considerations

With reciprocal methods, the usual determining question is *'how bad are the characteristics of a thru?'* in the environment in question. As suggested earlier, if the thru is good (RL  $\sim$  >25 dB and insertion loss known to within  $\sim$ 0.05 dB), then for most purposes, the defined thru methods will do better since there is a more explicit determination of load match. As the reciprocal device worsens in terms of insertion loss and match, the sensitivity of the calibration to small standards problems will increase because less and less information is available to the calibration. In this sense, sensitivity may be a more practical metric than best-obtainable uncertainty, which will be fairly similar in all cases.

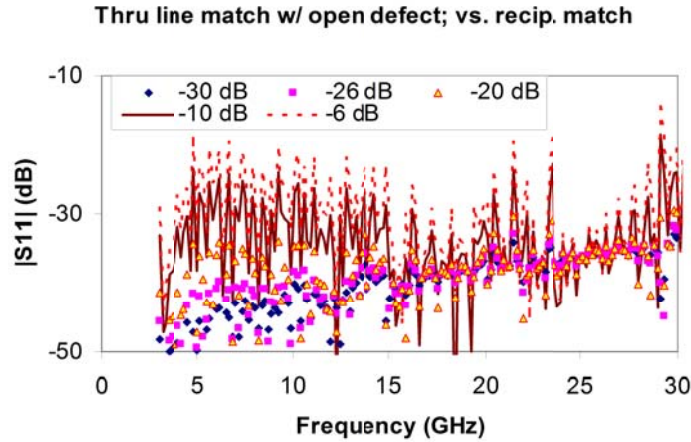
When the available thru is poor, however, then the absolute defined thru uncertainty will be high. In one example, delay insertion loss deviation was plotted for two calibrations (SOLT and SOLR) where the only interconnect available had 8 to 15 dB return loss across the band. The SOLT measurement shows almost 0.7 dB deviation (on a low loss device) while the SOLR deviation was kept to < 0.2 dB as shown in [Figure 15-3](#).



**Figure 15-3.** An example comparison (insertion loss deviation) is shown here between SOLT and SOLR when no good thru connection was available.

There are limits on the reciprocal network, as discussed above, and those will become most apparent when measuring reflection of well-matched, low insertion loss devices. The one mitigating factor is that if the media is complicated enough to require a reciprocal technique, there will be fewer well-matched, low insertion loss devices to be concerned about. The issue becomes one where the resolution on load match during calibration becomes limited by the reciprocal itself, so the correction for that term will become more sensitive.

As an example, consider the match measurement of a delay line where a problem was introduced on the open standard during the calibration. A series of different calibrations were done with different reciprocal devices (with different match levels). The resultant measurements are shown in Figure 15-4. For reciprocal elements with reasonable match ( $\sim < -20$  dB), the measurements did not become distorted significantly by the open calibration error. At the  $-10$  dB reciprocal match level, measurements below ( $\sim -20$  dB) were impacted. At the  $-6$  dB reciprocal match level, even higher reflection measurements would have been distorted. A somewhat obvious guiding principle is that the reciprocal used for the calibration should not be worse (in terms of return loss or insertion loss) than the devices that will be measured with that resulting calibration.



**Figure 15-4.** A plot of sensitivity of return loss measurements to a problem with one of the reflection standards is shown here for a variety of reciprocal devices used during the calibration.

# Chapter 16 — Multiport Measurements

## 16-1 Introduction to Multiport

The MS46524B is a 4 port VNA with multiport measurement capabilities. This VNA can make 1-Port to 4-Port measurements for many applications:

- Balanced/differential device measurements
- Balanced to unbalanced device measurements (including baluns and other hybrids)
- General 3-Port and 4-Port microwave devices (such as splitters, hybrids, circulators, couplers, or distribution networks)
- Multiple measurements of one and two port devices for a fast, manufacturing test setup

The purpose of this chapter is to introduce the measurement configuration, some basic multiport S-parameter definitions, calibrations, and how many of the measurement steps discussed earlier in this guide are generalized for the multiport scenario.

## 16-2 Shockline™ MS46524B VNA

The Shockline™ MS46524B-010 4-port VNA shown in [Figure 16-1](#)) provides coverage from:

- MS46524B-010 VNA, 50 kHz to 8.5 GHz, 4-port
- MS46524B-020 VNA, 50 kHz to 20 GHz, 4-port
- MS46524B-040 VNA, 50 kHz to 43.5 GHz, 4-port



**Figure 16-1.** Shockline™ MS46524B-010

## Blocking Test Set Combinations

Not every VNA port can be connected to every test set port (termed a blocking test set). All 16 4-Port S-parameters can be easily measured but not with an arbitrary setup. The VNA application handles all of these tasks automatically so this detail is normally invisible to the user. It does, however, have some impact on measurement time since there is a limitation on how many parameters can be measured when the VNA is in sequential sweep mode with a single switch configuration (for example,  $S_{11}$  and  $S_{21}$  at the 4-Port plane cannot be measured simultaneously). In those situations when multiple switch configurations are required, the VNA application will automatically handle those tasks. The MS46524B-010 can reduce measurement time when using Simultaneous sweep mode because the single switch limitation is not applicable.

See [Chapter 14, “Measurement - Sweep Types”](#).

## 16-3 Conventional (Single-Ended) S- and User-Defined Parameters

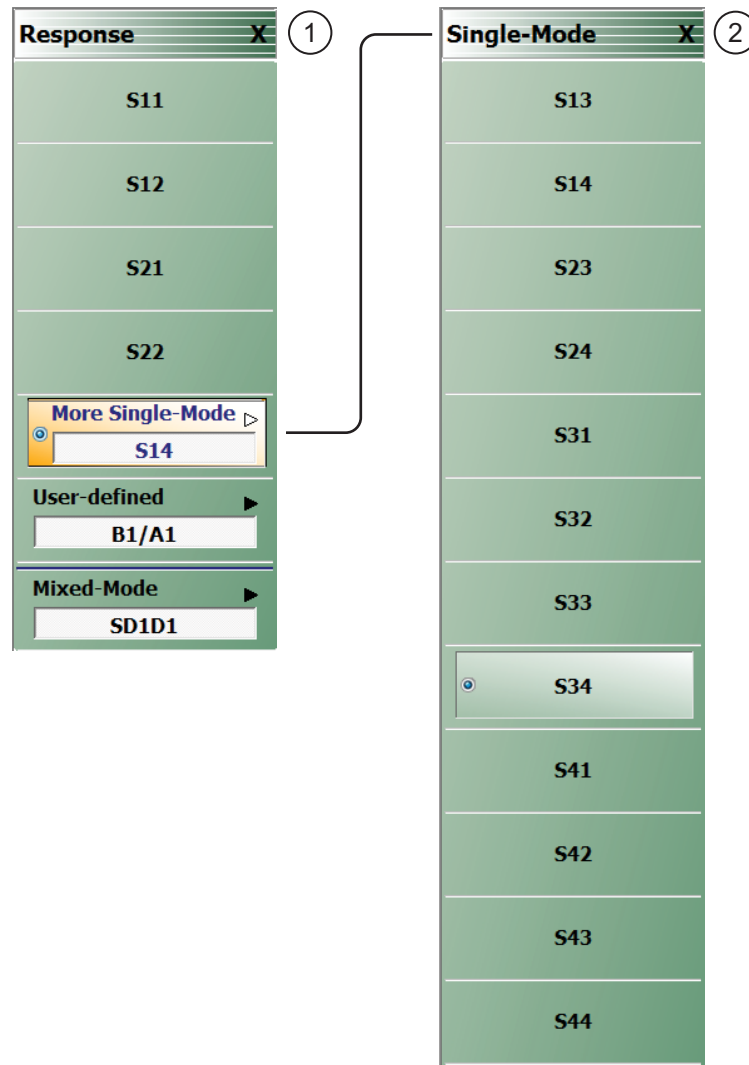
There are 16 possible S-parameters when measuring a 4-Port device, as demonstrated by the defining equation (Eq. 16-1).

$$\begin{bmatrix} b_1 \\ b_2 \\ b_3 \\ b_4 \end{bmatrix} = \begin{bmatrix} S_{11} & S_{12} & S_{13} & S_{14} \\ S_{21} & S_{22} & S_{23} & S_{24} \\ S_{31} & S_{32} & S_{33} & S_{34} \\ S_{41} & S_{42} & S_{43} & S_{44} \end{bmatrix} \begin{bmatrix} a_1 \\ a_2 \\ a_3 \\ a_4 \end{bmatrix}$$

**Equation 16-1** S-Parameter Defining Equation



The primary **RESPONSE** menu and the **SINGLE-MODE** submenu for additional standard S-parameters are shown in [Figure 16-2](#). All of the parameters are available regardless the calibration in place so some parameters could be uncorrected depending on the calibration.



- |  |  |
|--|--|
| 1. The 4-Port version of the <b>RESPONSE</b> menu provides S-Parameter selections for S11, S12, S21, and S2. | 2. The <b>SINGLE-MODE</b> submenu provides S-Parameter selections from S13 to S44. |
|--|--|

**Figure 16-2.** **RESPONSE** and **SINGLE-MODE** Menus

The expected user-defined parameters can be selected as suggested by the menus below (Figure 16-3). Note that any of the four ports may be defined as the driver (or sourcing) port. The allowed numerator and denominator values for user-defined are  $a_1, a_2, a_3, a_4, b_1, b_2, b_3, b_4$  and 1 as suggested by the figure. Note that only the NUMERATOR menu is shown here for simplicity, the DENOMINATOR menu has the same selections.

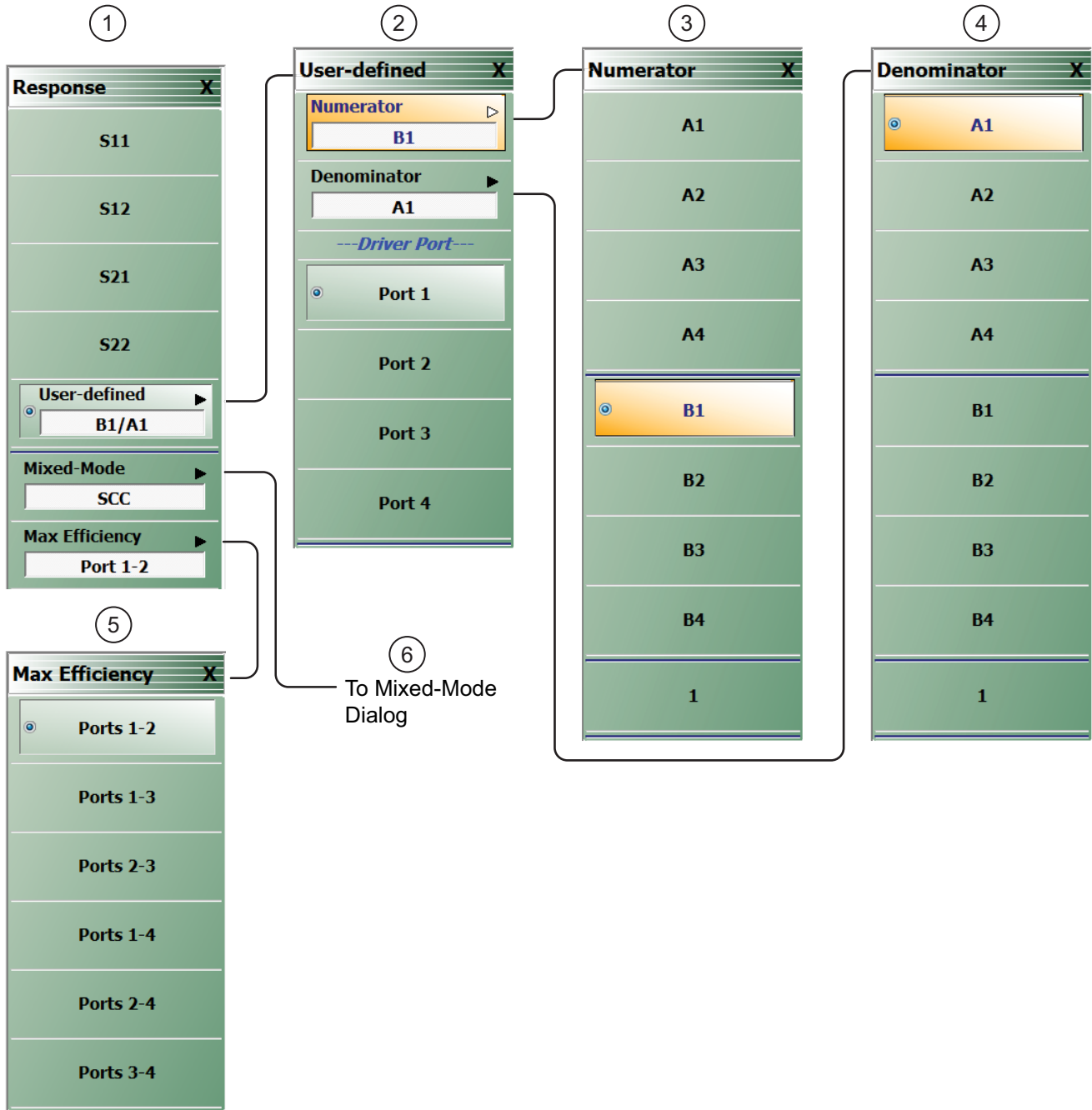


Figure 16-3. RESPONSE, USER-DEFINED, and NUMERATOR Menus

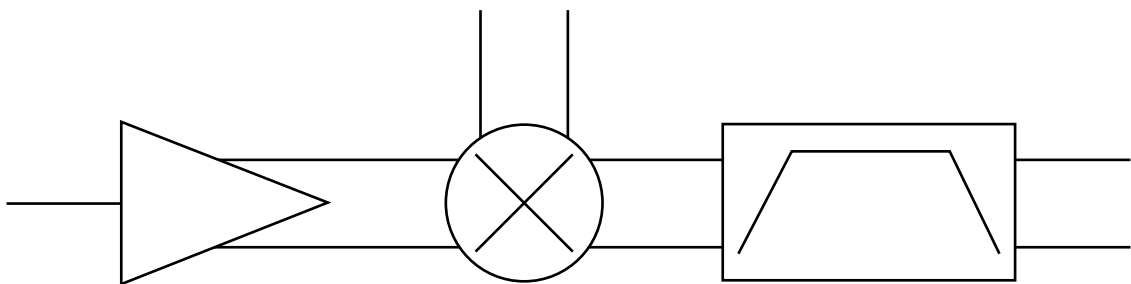
- |  |   |
|--|---|
| <ol style="list-style-type: none"> <li>1. The 4-Port version of the <b>RESPONSE</b> menu and the submenus linking from the <b>User-Defined</b> button.</li> <li>2. On the lower level of the <b>USER-DEFINED</b> response submenu (at center), any one of the four ports may be sourcing RF power as the “driver” port. On the upper level of the <b>USER-DEFINED</b> menu, selections are made for the numerator and denominator values of user-defined parameter.</li> </ol> | <ol style="list-style-type: none"> <li>3. The <b>NUMERATOR</b> menu (at upper right) menu for user-defined parameters is a submenu to the <b>USER-DEFINED</b> menu.</li> <li>4. The equivalent <b>DENOMINATOR</b> menu (at lower right) is not shown.</li> <li>5. <b>Max Efficiency</b> Menu</li> <li>6. To <b>Mixed Mode</b> Dialog Box</li> </ol> |
|--|---|

**Figure 16-3.** RESPONSE, USER-DEFINED, and NUMERATOR Menus

When a channel is constructed of many traces measuring these parameters, the system will determine the optimal sweep combination to get at all of the required measurements as discussed earlier. The measurement time can be difficult to predict since there are a large number of possible combinations and the test set is partially blocking. Considering again the block diagram of [Figure 16-9](#),  $S1x$  and  $S2x$  cannot be measured simultaneously nor can  $S3x$  and  $S4x$ . When those pairs (or equivalent  $b_i$  measurements) are present in a given channel, extra switching and time will be required. The switching was kept simplified to maintain low insertion loss in the test set at the higher microwave frequencies.

## 16-4 Mixed-Mode Parameters

The reader will have noted another submenu in the response category that describes mixed-mode parameters. One is likely familiar with the concept of a differential amplifier and the general concepts of differential and common-mode signals [2] as suggested by [Figure 16-4](#). It is clear that it may be useful to represent S-parameter data in a form corresponding to differential drive/reception (and similarly for common-mode). Such a formulation has been developed in the past (e.g., [1]-[4]). The purpose of this section is to describe and define this representation, provide some hints on data interpretation along with explaining how to setup the desired responses.

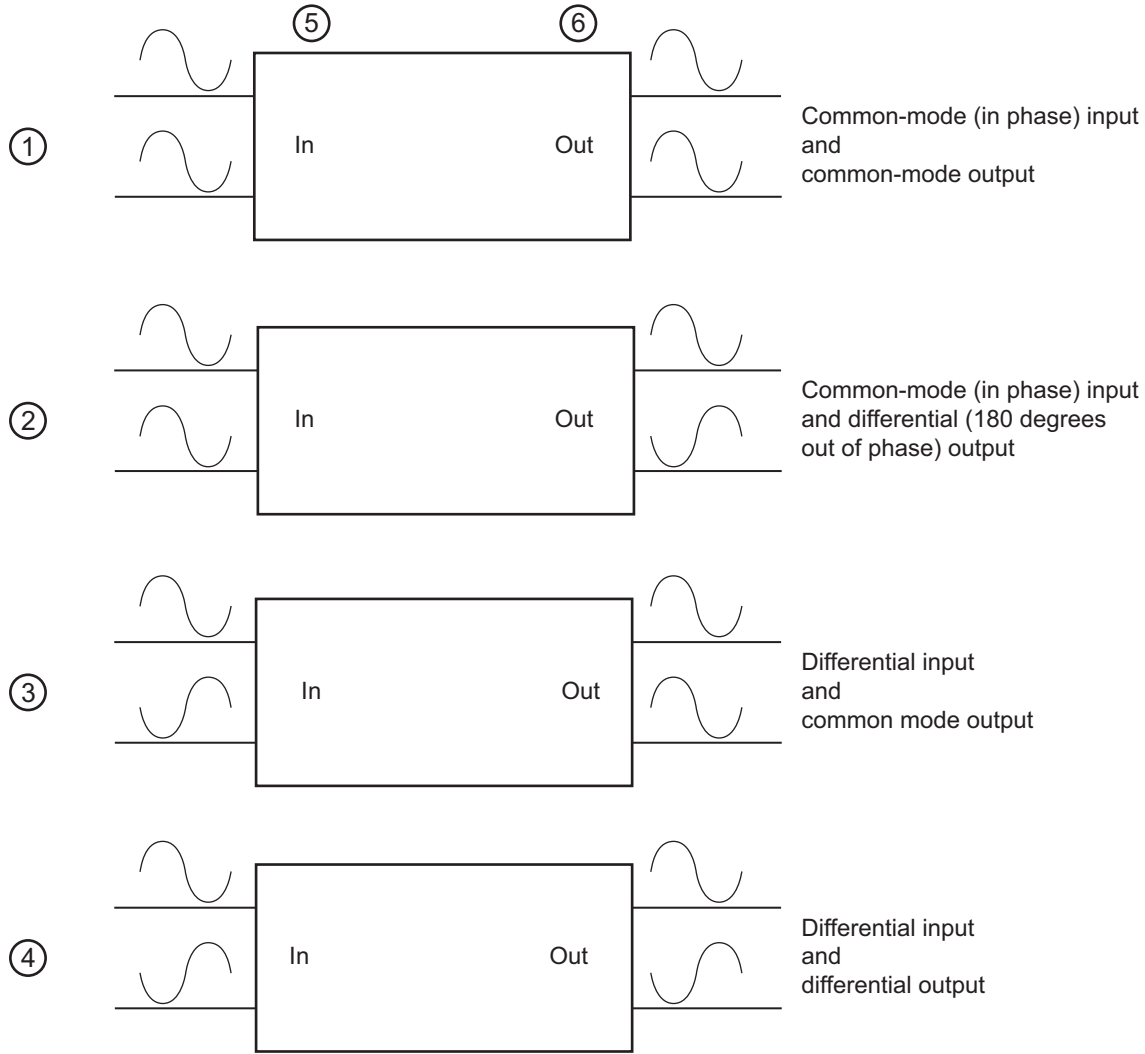


A portion of a common communications circuit is shown here where a number of components are driven differentially. It is of obvious interest to characterize these parts in terms of differential and common mode signals.

**Figure 16-4.** Characterizing Differentially Driven Components

The concept here is one of a pair of ports being driven at a time, either in-phase (common mode drive) or 180 degrees out of phase (differential drive). Similarly, we are interested in the received signal in a port pair context: what is the common-mode (in-phase) signal received and what is the differential signal received. In contrast to the single-ended drive and single-ended receive types of parameters are conventionally used, these parameters represent a transformation of the data.

This combined signal drive concept can also be explained pictorially. Each pair (either 1-2 or 3-4) can be driven either in phase (common mode drive) or 180 degrees out of phase (differential drive). For the transformation, it is convenient to group together single ended ports 1 and 2 together as the new Port 1 (which can be driven differentially, common-mode, or some combination). Similarly, single ended Ports 3 and 4 will be grouped as the new Port 2 (same idea: differential, common-mode, or combination). Thus the new basis is to think of a port pair as being driven in phase or 180 degrees out of phase (instead of thinking of each port of the pair being driven individually). The new input and output bases are illustrated below (Figure 16-5). The reader may recognize this as a simple shift in basis, which can be thought of as a 45 degree rotation.



The new basis for analyzing mixed-mode S-parameters are shown here. With the physical ports considered as pairs, one can analyze in terms of common-mode and differential drive and common-mode and differential output.

1. Common-mode (in phase) input and common-mode output.

2. Common-mode (in phase) input and differential (180 degrees out-of-phase) output.

3. Differential input and common-mode output.

4. Differential input and differential output.

5. Input Side (at left).

6. Output Side (at right)

**Figure 16-5.** Analyzing Mixed-Mode S-Parameters

A common question is whether these ports need to be driven with pure differential and common-mode signals or whether the same result can be achieved by mathematical superposition of single-ended signals. With certain assumptions on linearity, the answer is yes and the derivation will be presented next. The only practical requirement is that the bulk of any strong non-linearity be after the first differential stage or that there is reasonable common-mode to differential isolation (e.g., [5]-[6]) which is true for many devices even when gain compression is being measured.

The next step is to construct S-parameters for this type of input/output. The possible incident waveforms can be deduced from Figure 16-5 above:

- differential on the new Port 1
- common-mode on Port 1
- differential on Port 2
- common-mode on Port 2

The output waves will have the same structure, which leads to the S-parameter matrix structure depicted in Eq. 16-2.

$$\begin{bmatrix} b_{d1} \\ b_{d2} \\ b_{c1} \\ b_{c2} \end{bmatrix} = \begin{bmatrix} S_{d1d1} & S_{d1d2} & S_{d1c1} & S_{d1c2} \\ S_{d2d1} & S_{d2d2} & S_{d2c1} & S_{d2c2} \\ S_{c1d1} & S_{c1d2} & S_{c1c1} & S_{c1c2} \\ S_{c2d1} & S_{c2d2} & S_{c2c1} & S_{c2c2} \end{bmatrix} \begin{bmatrix} a_{d1} \\ a_{d2} \\ a_{c1} \\ a_{c2} \end{bmatrix} = \begin{bmatrix} S_{dd} & S_{dc} \\ S_{cd} & S_{cc} \end{bmatrix} \begin{bmatrix} a_{d1} \\ a_{d2} \\ a_{c1} \\ a_{c2} \end{bmatrix}$$

#### Equation 16-2.

Here the four S blocks in the square matrix to the right are actually submatrices [2].  $S_{dd}$  corresponds to the four purely differential S-parameters while  $S_{cc}$  corresponds to the four purely common-mode parameters. The other two quadrants cover the mode-conversion terms. These are expanded in the center part of Eq. 16-2. The matrix equation can be interpreted as expressing an output wave  $b_i$  in terms of the four possible input waves  $a_{d1}$ ,  $a_{d2}$ ,  $a_{c1}$ , and  $a_{c2}$ . An example of one of these sub-equations is shown below.

$$b_{d1} = S_{d1d1}a_{d1} + S_{d1d2}a_{d2} + S_{d1c1}a_{c1} + S_{d1c2}a_{c2}$$

#### Equation 16-3.

It is straightforward to write the relationships between the single-ended incident and reflected waves and the new balanced versions. To simplify the presentation, the next set of equations will assume port pair 1 is composed of physical ports 1 and 2 while port pair 2 is composed of physical ports 3 and 4. We will show a means of generalizing this construction later. The difference and sum choices are obvious for differential and common-mode waves, respectively, and all else that is needed is a normalization factor to keep power levels equivalent.

$$\begin{aligned}
 a_{d1} &= \frac{1}{\sqrt{2}}(a_1 - a_2) \\
 a_{e1} &= \frac{1}{\sqrt{2}}(a_1 + a_2) \\
 a_{d2} &= \frac{1}{\sqrt{2}}(a_3 - a_4) \\
 a_{e2} &= \frac{1}{\sqrt{2}}(a_3 + a_4) \\
 b_{d1} &= \frac{1}{\sqrt{2}}(b_1 - b_2) \\
 b_{e1} &= \frac{1}{\sqrt{2}}(b_1 + b_2) \\
 b_{d2} &= \frac{1}{\sqrt{2}}(b_3 - b_4) \\
 b_{e2} &= \frac{1}{\sqrt{2}}(b_3 + b_4)
 \end{aligned}$$

---

**Equation 16-4.**

This linear combination of single-ended wave functions makes the transformation particularly transparent. One can define a simple transformation matrix to operate on single ended S-parameters to produce the mixed-mode S-parameters that are shown below. The parameters are grouped by the quadrants labeled in [Eq. 16-2](#).

The differential-to-differential terms:

$$\begin{aligned}
 S_{d1d1} &= \frac{1}{2}(S_{11} - S_{21} - S_{12} + S_{22}) \\
 S_{d1d2} &= \frac{1}{2}(S_{13} - S_{23} - S_{14} + S_{24}) \\
 S_{d2d1} &= \frac{1}{2}(S_{31} - S_{41} - S_{32} + S_{42}) \\
 S_{d2d2} &= \frac{1}{2}(S_{33} - S_{43} - S_{34} + S_{44})
 \end{aligned}$$

---

**Equation 16-5.**

The common mode-to-common mode terms:

$$S_{c1c1} = \frac{1}{2}(S_{11} + S_{21} + S_{12} + S_{22})$$

$$S_{c1c2} = \frac{1}{2}(S_{13} + S_{23} + S_{14} + S_{24})$$

$$S_{c2c1} = \frac{1}{2}(S_{31} + S_{41} + S_{32} + S_{42})$$

$$S_{c2c2} = \frac{1}{2}(S_{33} + S_{43} + S_{34} + S_{44})$$

---

**Equation 16-6.**

The common mode-to-differential terms:

$$S_{d1c1} = \frac{1}{2}(S_{11} - S_{21} + S_{12} - S_{22})$$

$$S_{d1c2} = \frac{1}{2}(S_{13} - S_{23} + S_{14} - S_{24})$$

$$S_{d2c1} = \frac{1}{2}(S_{31} - S_{41} + S_{32} - S_{42})$$

$$S_{d2c2} = \frac{1}{2}(S_{33} - S_{43} + S_{34} - S_{44})$$

---

**Equation 16-7.**

and the differential-to-common mode terms:

$$S_{c1d1} = \frac{1}{2}(S_{11} + S_{21} - S_{12} - S_{22})$$

$$S_{c1d2} = \frac{1}{2}(S_{13} + S_{23} - S_{14} - S_{24})$$

$$S_{c2d1} = \frac{1}{2}(S_{31} + S_{41} - S_{32} - S_{42})$$

$$S_{c2d2} = \frac{1}{2}(S_{33} + S_{43} - S_{34} - S_{44})$$

---

**Equation 16-8.**

The simple linear relationship between the parameters should be evident. Just to reinforce the interpretation of these parameters:  $S_{d2d1}$  is the differential output from composite Port 2 (the old Ports 3 and 4) ratioed against a differential drive into composite port 1 (the old Ports 1 and 2). Similarly  $S_{c2c2}$  would be the common-mode reflection off of composite Port 2 ratioed against the common-mode signal applied to composite Port 2.

## MIXED MODE Dialog Box

The dialog for selecting a mixed mode parameter in this sense is shown in [Figure 16-6](#).

- MAIN | Response | RESPONSE | Mixed-Mode | MIXED MODE Dialog Box

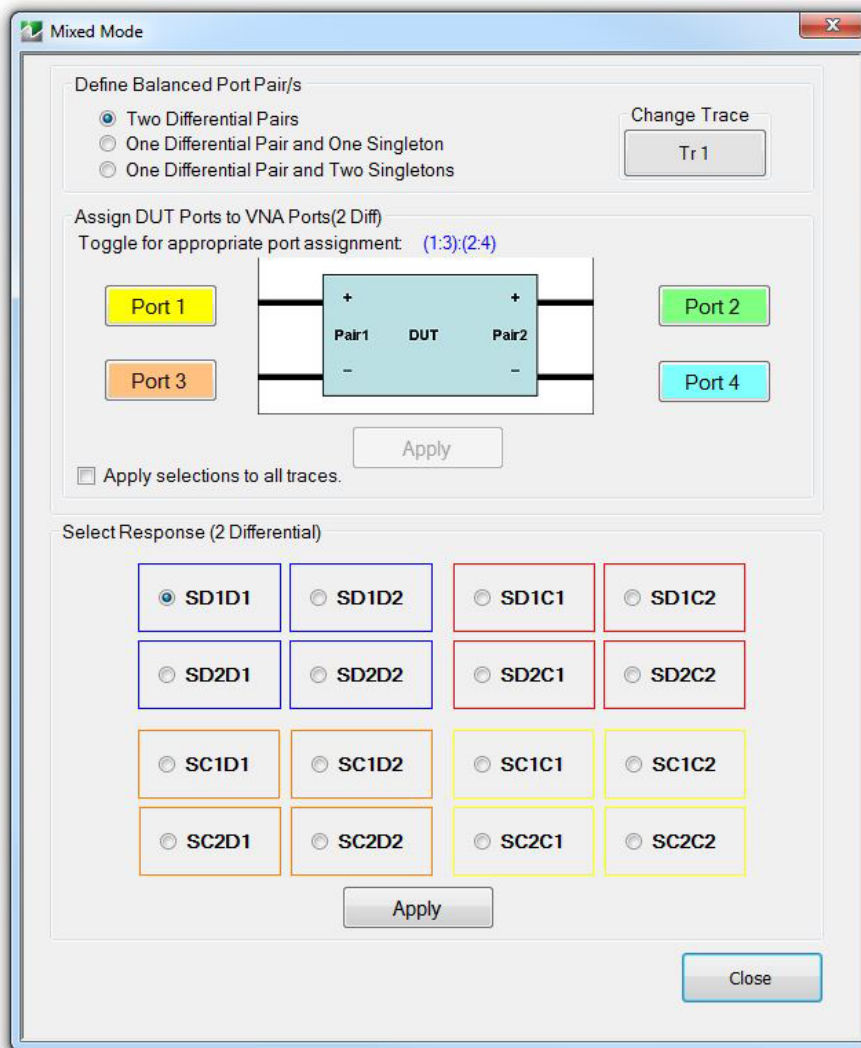
Aside from selecting among the 16 parameters described above, there is also the matter of defining the port pairs. This is accomplished in the middle part of the dialog and note that there is a polarity sense assigned to the pairing (determines the sign of the differential signals). When displaying the parameters, this port assignment must also be conveyed and is done with the following symbolism:

- (A:B):(C:D) (where A, B, C, and D are unique port numbers from {1,2,3,4})

Here, the first port pair is A-B (with A assigned the positive polarity) and the second port pair is C-D (with C assigned the positive polarity).

For example:

- (1:2):(3:4) The first port pair is measured from 1 to 2 and the second port pair is measured from 3 to 4.
- (1:2):(4:3) The first port pair is measured from 1 to 2 and the second port pair is measured from 4 to 3.



The dialog for selecting mixed-mode parameters, configured for two differential pairs, is shown here. The instrument defaults to the SD1D1 response.

**Figure 16-6.** MIXED MODE Two Differential Pairs Dialog Box



The 3-Port version of these mixed-mode parameters is a straightforward simplification. Port X will remain single ended while ports Y and Z will form a balanced port pair. Following the analysis path from before:

$$\begin{bmatrix} b_x \\ b_d \\ b_c \end{bmatrix} = \begin{bmatrix} S_{xx} & S_{xd} & S_{xc} \\ S_{dx} & S_{dd} & S_{dc} \\ S_{cx} & S_{cd} & S_{cc} \end{bmatrix} \begin{bmatrix} a_x \\ a_d \\ a_c \end{bmatrix}$$

**Equation 16-9.**

$$\begin{aligned} a_d &= \frac{1}{\sqrt{2}} (a_y - a_z) \\ a_c &= \frac{1}{\sqrt{2}} (a_y + a_z) \\ b_d &= \frac{1}{\sqrt{2}} (b_y - b_z) \\ b_c &= \frac{1}{\sqrt{2}} (b_y + b_z) \end{aligned}$$

**Equation 16-10.**

$$\begin{aligned} S_{xd} &= \frac{1}{\sqrt{2}} (S_{xy} - S_{xz}) \\ S_{xc} &= \frac{1}{\sqrt{2}} (S_{xy} + S_{xz}) \\ S_{dx} &= \frac{1}{\sqrt{2}} (S_{yx} - S_{zx}) \\ S_{cx} &= \frac{1}{\sqrt{2}} (S_{yx} + S_{zx}) \\ S_{dd} &= \frac{1}{2} (S_{yy} - S_{yz} - S_{zy} - S_{zz}) \\ S_{cc} &= \frac{1}{2} (S_{yy} + S_{yz} + S_{zy} + S_{zz}) \\ S_{dc} &= \frac{1}{2} (S_{yy} + S_{yz} - S_{zy} - S_{zz}) \\ S_{cd} &= \frac{1}{2} (S_{yy} - S_{yz} + S_{zy} - S_{zz}) \end{aligned}$$

**Equation 16-11.**

In Equation Group 11 ([Eq. 16-11](#)), the subscript  $x$  remains since that port is defined solely as a single-ended port.

The three port configuration is termed a differential pair and a singleton and the dialog for selecting this type of parameter is shown in Figure 16-7. Note that one can define this parameter class even if a 4-Port calibration is applied; it is a matter of port assignment. As with the dual differential case, the ports must be assigned with polarity in mind.

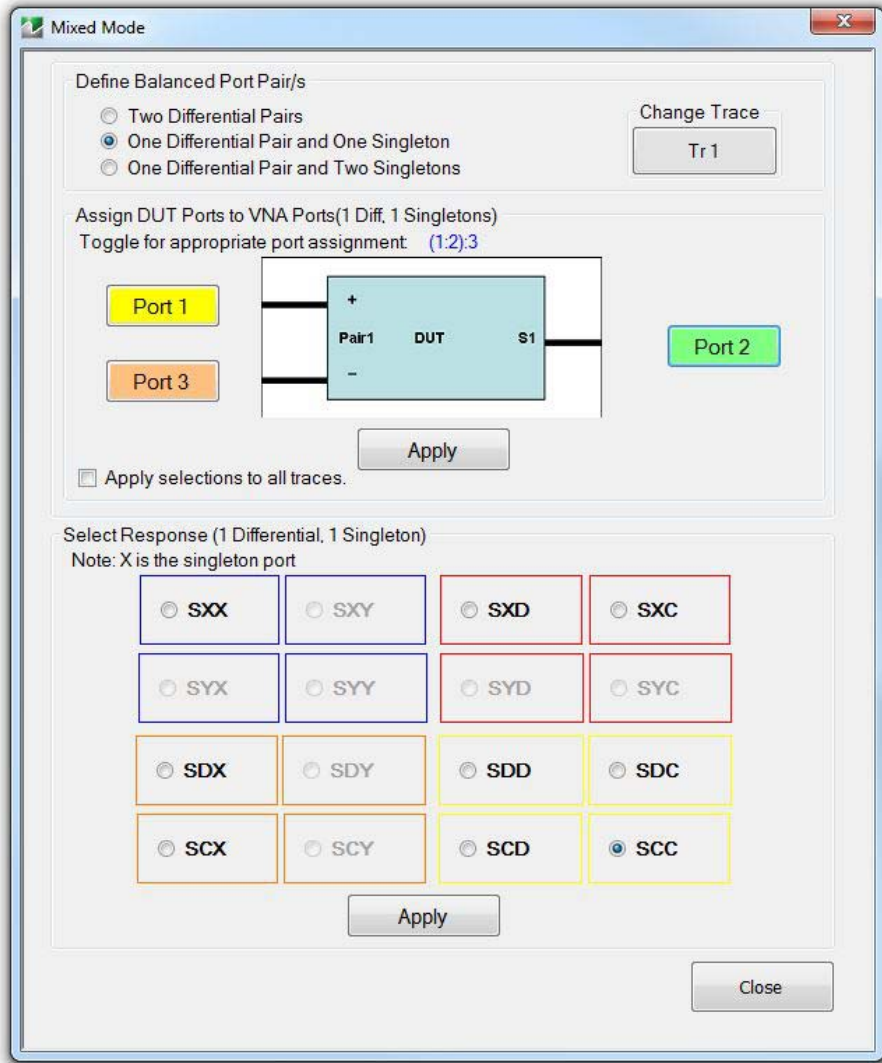
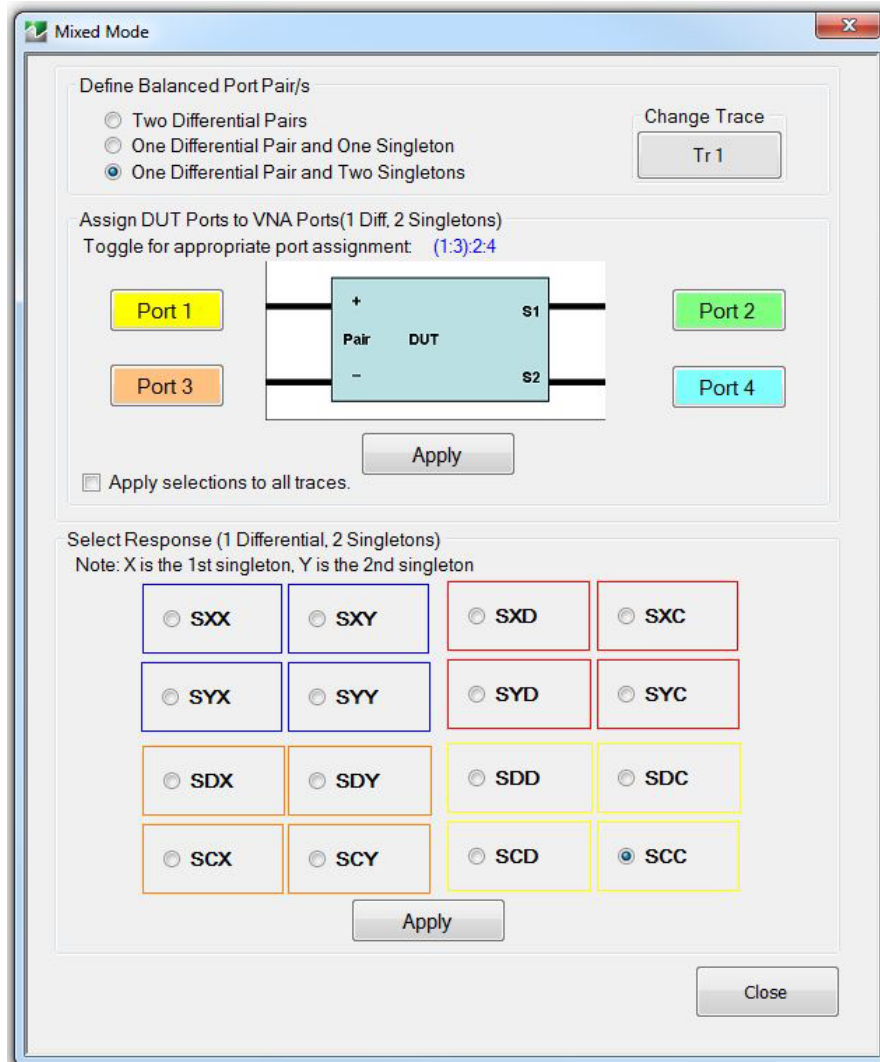


Figure 16-7. MIXED MODE One Differential Pair and One Singleton Dialog Box

For the situation in the figure above (Figure 16-7), there will be a different annotation on the graph legends to denote how the ports are configured but it is similar to the two-differential-pair format discussed earlier. (1:2):3 denotes that the differential pair is measured from Port 1 to Port 3 and Port 2 is the singleton.

Certain 4-Port devices are configured as one differential pair plus two single-ended ports. The parameters can then be configured in a one differential pair and two singleton format. The mixed mode definitions are identical to those presented above for the 1 singleton case. Now there is just a different possible free port number running around in the definition and 16 parameters are again possible. This selection structure is shown below in [Figure 16-8](#).



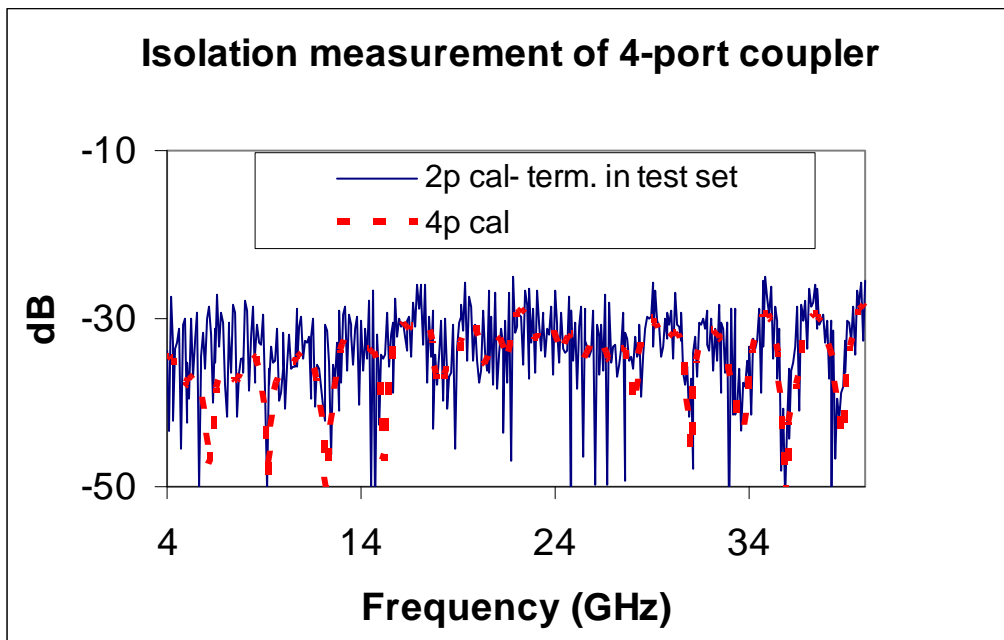
**Figure 16-8.** MIXED MODE One Differential Pair and Two Single-Ended Ports Dialog Box

On the graph legends, a format like (1:3):2:4 will be used to denote the port configuration. In this example, the differential pair is measured from Port 1 to Port 3, Port 2 is the first singleton and Port 4 is the second singleton.

## 16-5 Calibrations

In earlier chapters, a considerable amount of detail on various calibration algorithms and calibration types has been covered. The 3-Port and 4-Port variants of these calibrations are different from their 2-Port relations in fairly straightforward ways. The purpose of this subsection is to show where the differences are and how these calibrations can be properly configured.

A logical starting point is to ask what is different between measuring, say  $S_{41}$ , using a 4-Port calibration versus measuring it with a 2-Port calibration while properly terminating Ports 2 and 3. The quick answer is nothing, assuming the terminations are of good quality and one does not care about measurement time when measuring many parameters (while one swaps terminations around to get all of the S-parameters). If one just connected Ports 2 and 3 of the DUT to VNA ports, the results would probably not be as good since the raw broadband return loss of a VNA port is usually not better than 15 dB. To illustrate this concept, consider the measurement of isolation of a 4-Port coupler ( $S_{41}$  in the previous discussion). If a full four port calibration is performed, the dotted line in [Figure 16-9](#) is obtained. If instead only a 2-Port cal is performed and the other coupler ports are left terminated in the test set (seeing the raw match of those ports), then the solid line of [Figure 16-9](#) is obtained. The error here could be on the order of 10 dB at the -30 dB level.



An example showing the measurement improvement of a full four port calibration over a partially terminated two port calibration is shown here.

**Figure 16-9.** Measurement Improvement for Full 4-Port Calibration

By performing a full 3- or 4-Port calibration, the effective return loss of those other ports is improved to that of the residual load match, typically 30-50 dB, depending on the calibration algorithm and components used, improving the measurement result. Overall measurement time and accuracy are the usual drivers for considering 3-Port and 4-Port calibrations.

The complete error model for  $N$  ports, as shown in [Figure 16-10](#), is an extension of the 2-Port error model covered in [Chapter 1, "Calibration Overview"](#). Directivity and match terms are functions of each port, and added for the additional ports.

### Tracking

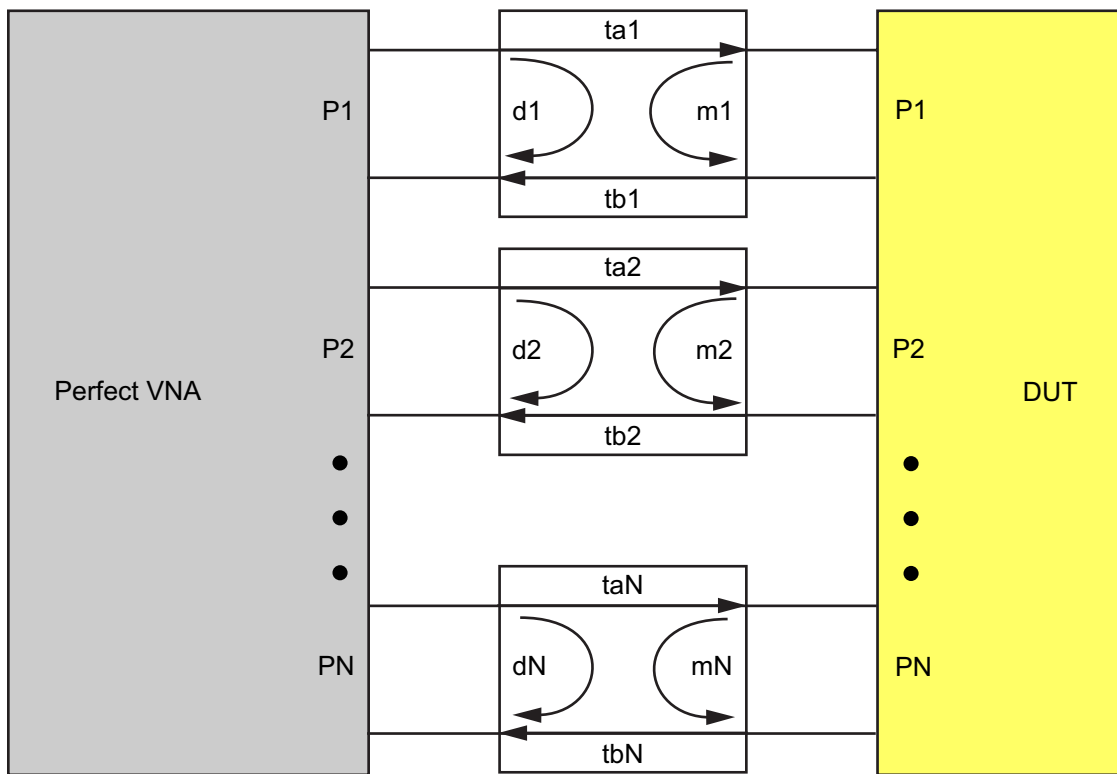
Tracking is again broken down into reflection tracking (the frequency response on a reflection measurement) and transmission tracking (the frequency response on a transmission measurement). Reflection tracking then also is a port property and can be assigned for each additional port. Transmission tracking is a property of a pair of ports (the correction to get a through line to measure  $S_{ij}=1$  after other port errors have been handled) hence this term must be assigned for every permutation of two ports.

### Isolation

Isolation is considered the property of a pair of ports requiring the same permutation. The last statement is not entirely valid if isolation is dependent on DUT impedances and is normally reserved to correct for isolation deep in the instrument. This distinction will be ignored for now since the isolation step is optional.

### New Error Model

Thus we have a fairly straightforward new error model as shown below (Figure 16-10). As before, the pair of lines (in the diagram) per port is to help delineate incident and reflected waves. The reflection tracking for port  $q$  can be thought of as the product of  $taq$  and  $tbq$ ; the transmission tracking from port  $k$  to port  $l$  can be thought of as the product of  $tak$  and  $tbl$  (no new information is being added, it is just being redistributed).



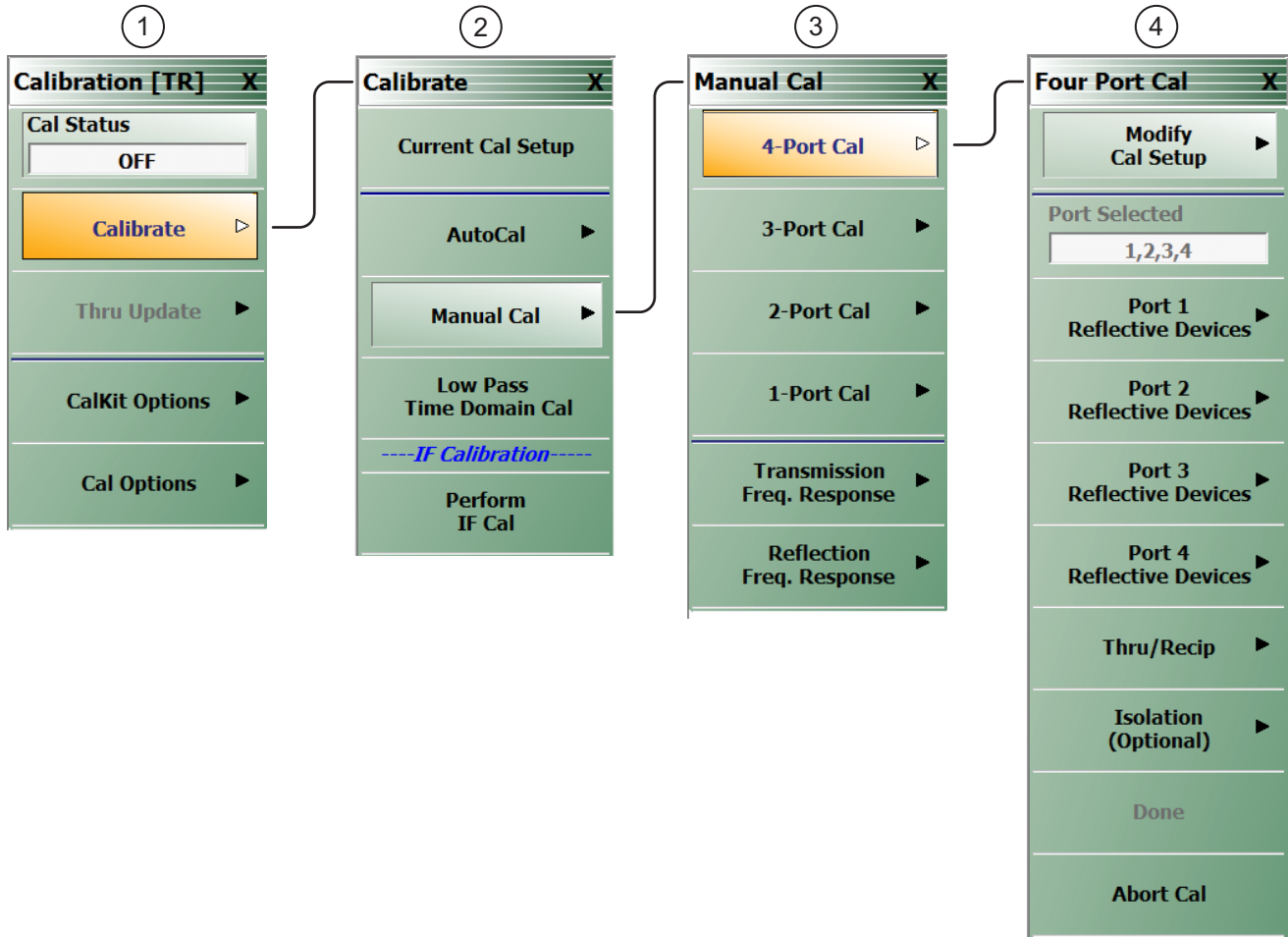
An N-Port error model is shown here. Directivity, match and reflection tracking can be assigned on a per-port basis while transmission tracking can be assigned on a pair-of-ports basis. Isolation is also nominally assigned on a pair-of-ports basis but that does have problems (isolation is often ignored practically).

**Figure 16-10.** N-Port Error Model

### Menus

The main calibration menu has a selection based on the type of calibration and the number of ports. The MANUAL CAL menu below (at #3 left in Figure 16-11) provides the selection path to the FOUR-PORT CAL menu (at #4 below). This menu is the calibration execution menu for a 4-Port calibration (defined standards call).

The second button from the top of the FOUR PORT CAL menu is a read-only field that displays the ports selected for the current calibration.



- |   |  |
|---|--|
| <ol style="list-style-type: none"> <li>1. <b>CALIBRATION</b> menu</li> <li>2. <b>CALIBRATE</b> menu</li> <li>3. <b>MANUAL CAL</b> menu provides access to all multiport calibration modes. The <b>4-Port Cal</b> button provides access to the <b>FOUR PORT CAL</b> procedure menu for a 4-Port VNA.</li> </ol> | <ol style="list-style-type: none"> <li>4. <b>FOUR PORT CAL</b> calibration execution menu for a 4-Port calibration (defined-standards calibration).</li> </ol> |
|---|--|

**Figure 16-11.** MANUAL CAL (MANUAL CALIBRATION) and FOUR PORT CAL Menus

## Transmission Tracking

The key complication of multiport calibrations lies in the handling of transmission tracking. Since the reflection and transmission tracking terms overlap, they are not entirely independent. The following equation reflects the relationship derived from the N-Port error model illustrated in [Figure 16-10 on page 16-15](#).

$$et_{kn} \cdot et_{nl} = et_{nn} \cdot et_{kl}$$

---

### Equation 16-12 Transmission Tracking Equation 1

This must be modified slightly for load match/source match changes, but the redundancy concept still applies. To see how this is used, consider the redundant through line (fully defined transmission line) problem. With connected throughs between Ports 1-2, 1-3, and 1-4 sequentially, the first three term types (directivity, source match, and reflection tracking) should have been computed for all four ports. The through connects allow us to compute all of the load match terms and all transmission tracking terms except for  $et_{32}$ ,  $et_{23}$ ,  $et_{24}$ ,  $et_{42}$ ,  $et_{34}$  and  $et_{43}$ . These last tracking terms can be found with the following forms of [Eq. 16-12](#) (above) shown below in [Eq. 16-13](#):

$$et_{43} = \frac{et_{41} \cdot et_{13}}{et_{11}} \quad (k = 4, l = 3, n = 1)$$

$$et_{32} = \frac{et_{31} \cdot et_{12}}{et_{11}} \quad (k = 3, l = 2, n = 1)$$

etc.

---

### Equation 16-13 Transmission Tracking Equation 2

The above is modified slightly because of match differences. This process is termed the use of redundancy since the reflect measurements and the through measurements do overlap to a certain degree. It is not necessary to connect all six (6) possible through lines in a 4-Port calibration or all three (3) possible through lines in a 3-Port calibration. The basic requirement is that all ports be “connected” in some way with a line. Additional throughs can always be used and can improve accuracy of the tracking terms by a certain amount.

In cases such as orthogonally positioned wafer process where it is difficult to construct a high quality line between ports, the use of redundancy will produce a better result than trying to use a poor through during the calibration. Similar analyses are used for all calibration types, giving the user considerable flexibility in defining the throughs/lines.

## Load Match

A related topic is load match (primarily for defined-standards calibrations) since it can generally be computed in multiple different ways since multiple throughs are involved. The guiding principle is the first-in rule: the first through measured will be used to compute the load match for the ports involved, the second through will be used for its ports but it will not overwrite earlier computed load matches, and so on. This allows the user to optimize load match performance by measuring the highest quality throughs first.

A consistent load match is guaranteed by using the VNA terminations to form the reference load for all transmission measurements. When a transmission parameter is measured, a unique load match is always defined, and the corrections are self-consistent.

## Setting Up the Defined Standards Calibration

The next topic is that of setting up the defined standards calibration. Consider the dialog shown below (Figure 16-12) that is used for setting up a 4-Port calibration using the SOLT/R algorithm.

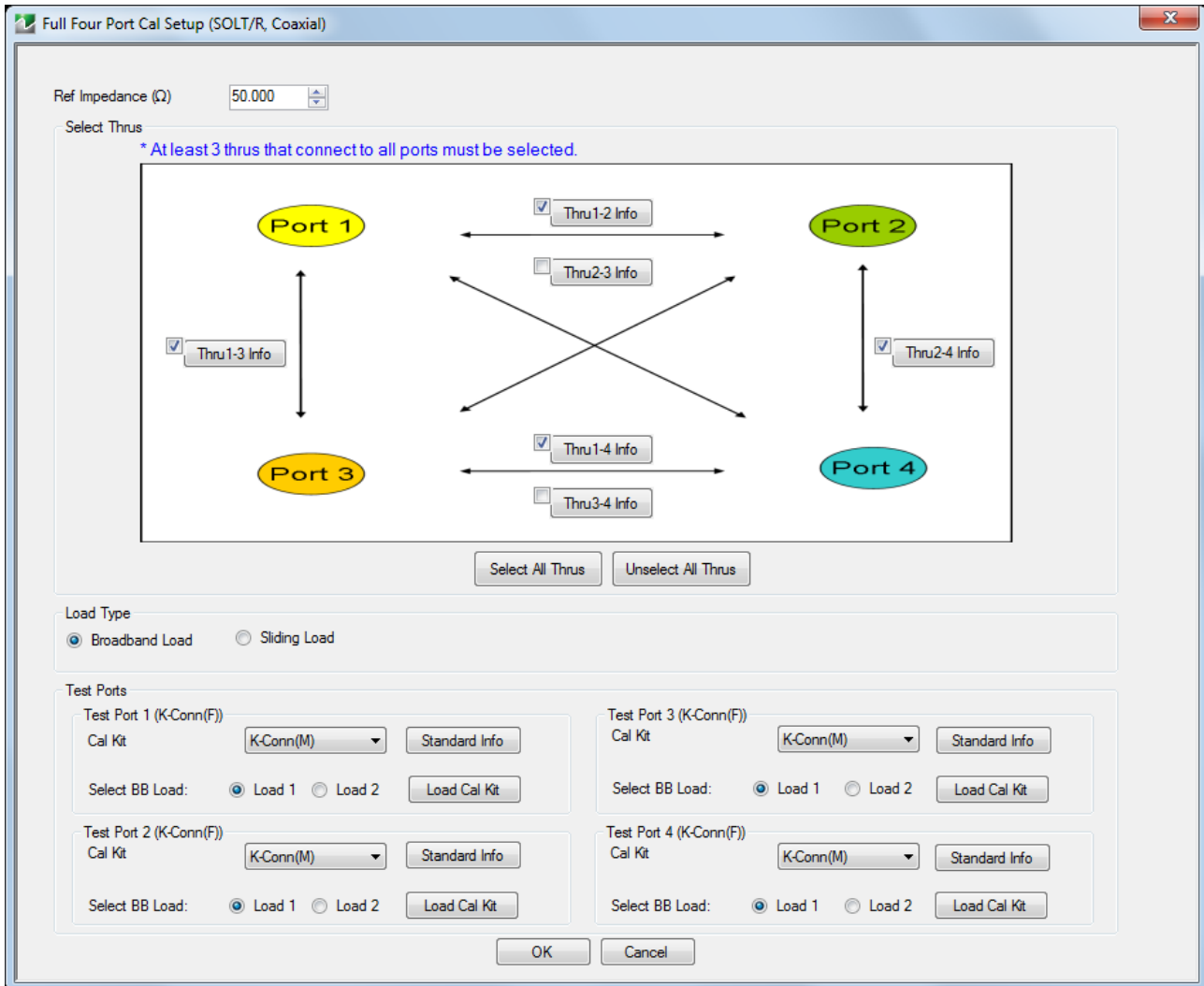


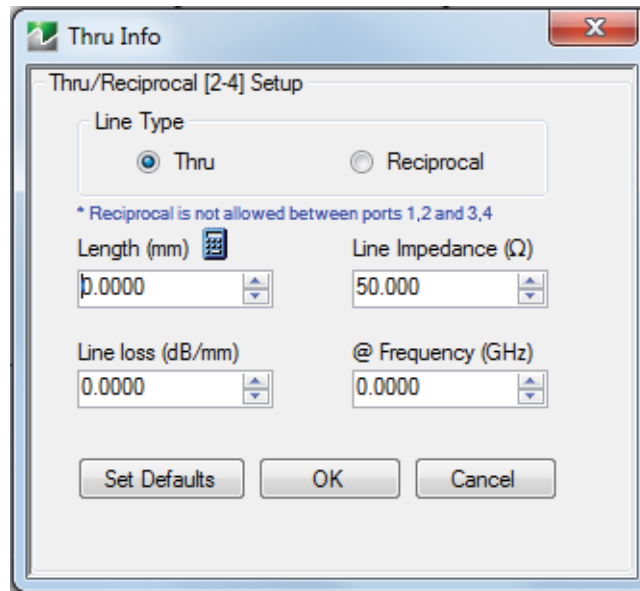
Figure 16-12. FULL FOUR PORT CAL SETUP Dialog Box - SOLT/R - Coaxial

### Selecting Possible Thrus

There are the usual items for selecting the port connector types, the type of load (broadband or sliding) and the reference impedance. What is somewhat different is the through selection tableau. The six possible thrus are shown, each having a button allowing the definition of that line as shown below (Figure 16-13). As discussed earlier, at least three thrus must be selected such that all ports are “connected.”

- Allowed:
  - 1-2, 1-3, and 1-4
  - 1-3, 2-4, and 1-4
  - Etc.
- Not allowed (without adding more lines):
  - 1-2, 1-3, and 2-3 (port 4 is not “connected”)



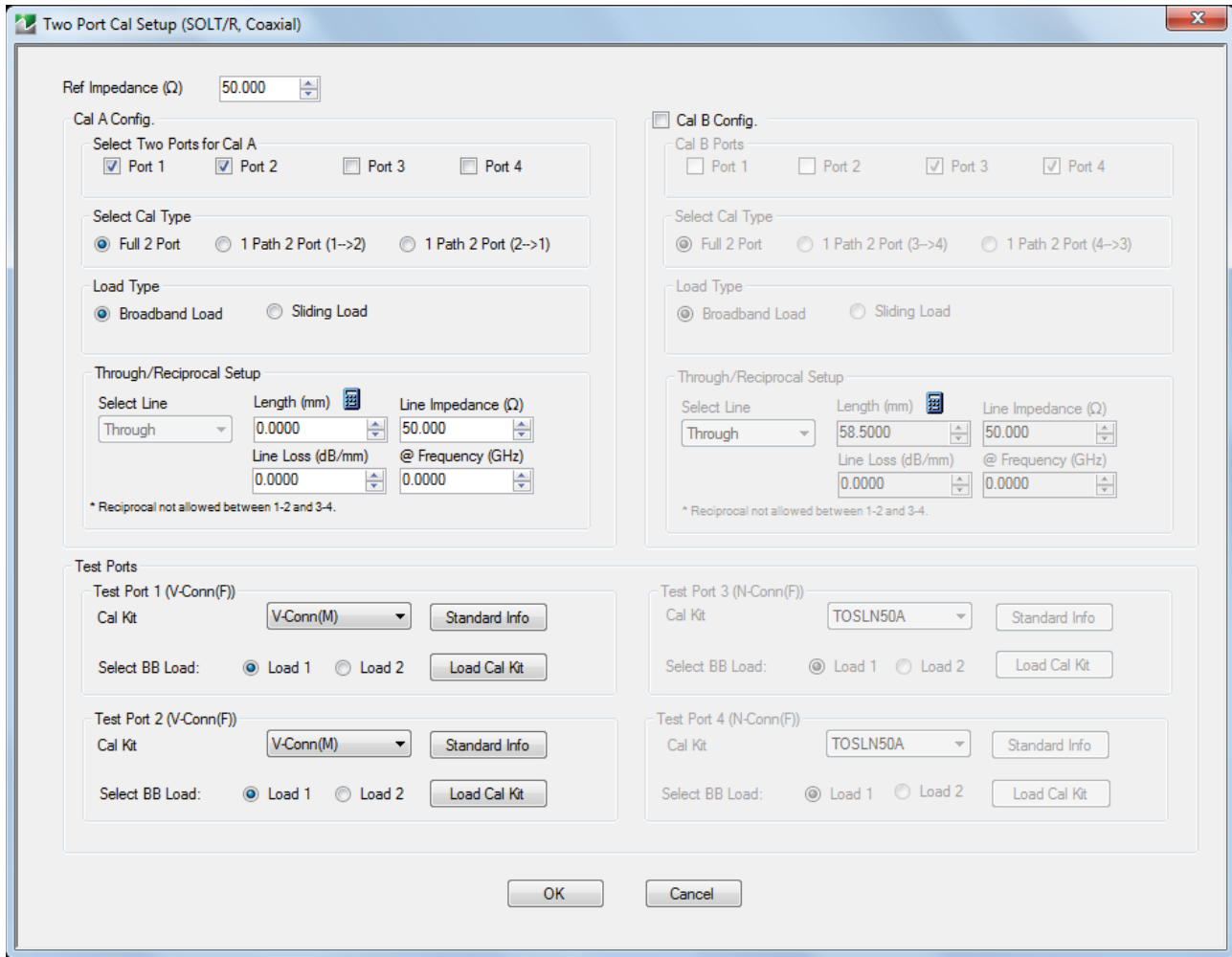


Typical through line configuration in the THRU INFO dialog box for the defined-standards calibrations.

**Figure 16-13.** THRU INFO Dialog Box

As shown in [Figure 16-13](#), each of the selections may be defined as a “through” or as a “reciprocal” as discussed in earlier chapters. From the point-of-view of “connectedness”, these designations are equivalent. As discussed in an earlier chapter, however, there is some accuracy degradation (particularly with regard to load match) that can be compounded if all lines are reciprocals. This point is discussed in more detail in the uncertainty section.

The three port calibration is analogous and the menus are covered in the operation guide. One port (to include reflection response calibrations) and two port calibrations are a little different in that multiple calibrations are allowed. Since it is a four port instrument, the user is allowed to perform two 2-Port calibrations or up to four 1-Port calibrations simultaneously. The two port calibration setup dialog is shown below (Figure 16-14) to illustrate the option of another calibration (Cal B in this dialog).

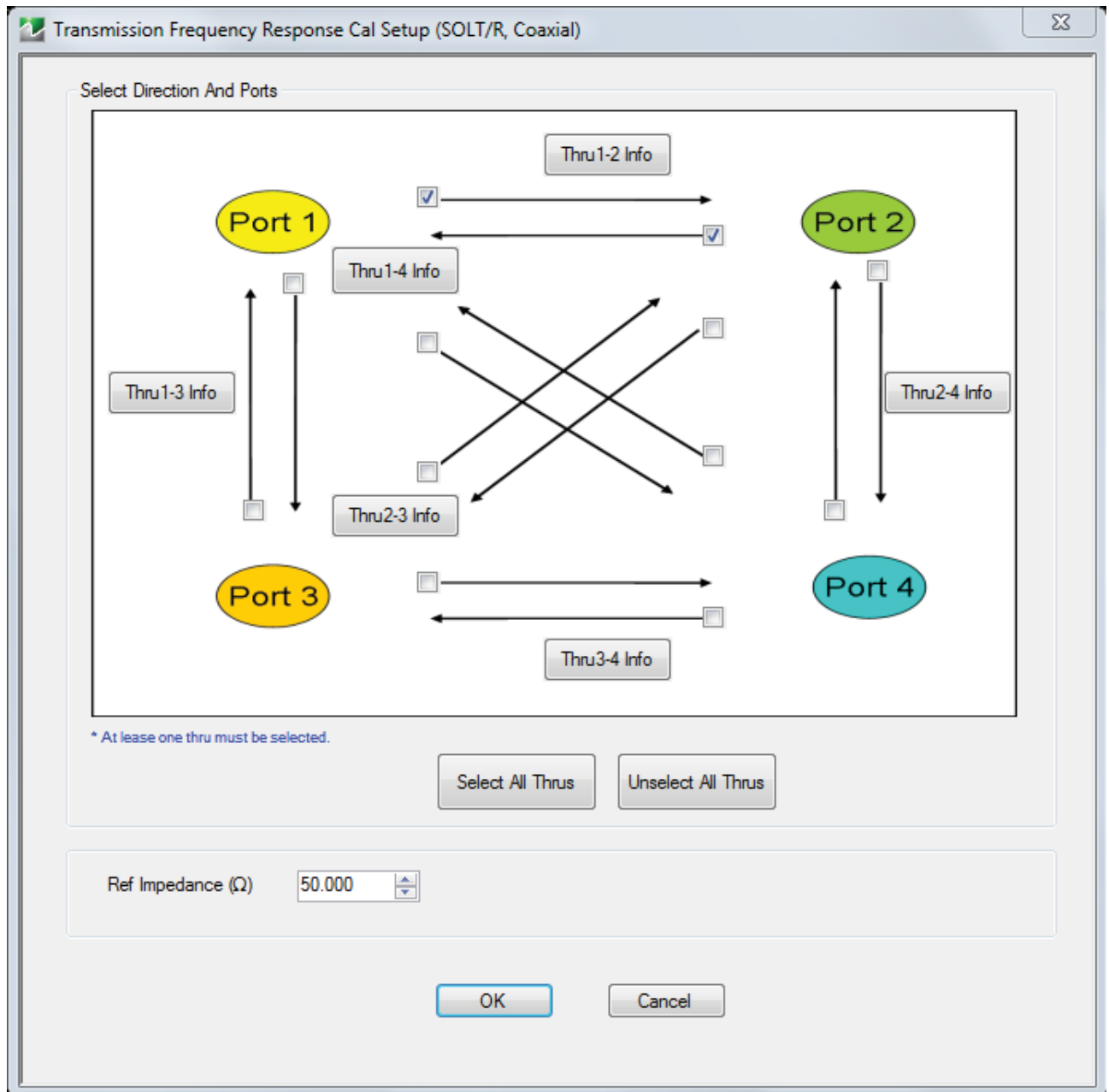


Typical calibration setup for a 2-Port calibration with selections of SOLT/R, Coaxial, and Cal B Not Selected. The two-port modify setup (SOLT/R) dialog is shown here to illustrate the multiple calibration functionality.

**Figure 16-14.** TWO PORT CAL SETUP (SOLT/R, COAXIAL) Dialog Box

If Cal B is activated from the check box, then the other two ports (not defined under Cal A) can be used to form an independent calibration. Port overlap is not allowed in order to avoid error-term self-consistency issues.

Transmission frequency response calibrations generalize as one might expect since there are now 12 transmission S-parameters potentially available to normalize. The dialog is shown below (Figure 16-15). As with the full calibrations, the throughs may be defined independently although the reciprocal choice is not available in this case. Note that unlike through selections in the full calibrations, the directions can be independently selected in this case. As is the case with two port systems, it is allowed to normalize, say,  $S_{21}$  but not  $S_{12}$ . In the full calibration case, both directions are always required.



The transmission frequency response modify setup dialog is shown here for a 4-Port system.

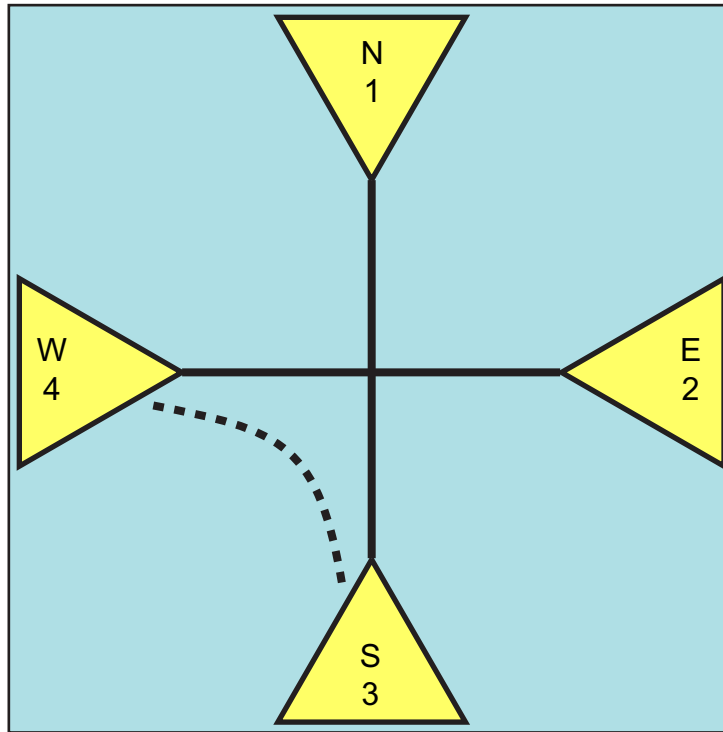
**Figure 16-15.** TRANSMISSION FREQUENCY RESPONSE CAL SETUP Dialog Box - SOLT/R - Coaxial

The above dialogs and setup requirements are completely analogous for SSLT/R and SSST/R algorithms. The LRL/LRM family, however, is somewhat different.

## LRL/LRM Calibrations

In this implementation LRL/LRM family, there is a basic structure that is fundamentally 2-Port like in nature. As such, the 4-Port LRL/LRM calibration will be defined as a pair of basic 2-Port calibrations linked together by one or more through measurements (to complete the path linkage as for defined-standards calibrations). This can have an additional benefit in certain cases since it allows the hybridization of reciprocal and defined-through approaches (on the additional paths) with LRL/LRM approaches on the base paths.

A situation where this is useful is shown in the figure below (Figure 16-16) where orthogonal on-wafer probes are being used. It is relatively easier to define good transmission lines on the horizontal and vertical paths (1-3 and 2-4) but less so, at least for higher frequencies, on the other paths (bends in the required lines causing radiation or otherwise leading to reflections). Such a problem is a good candidate for hybridization.

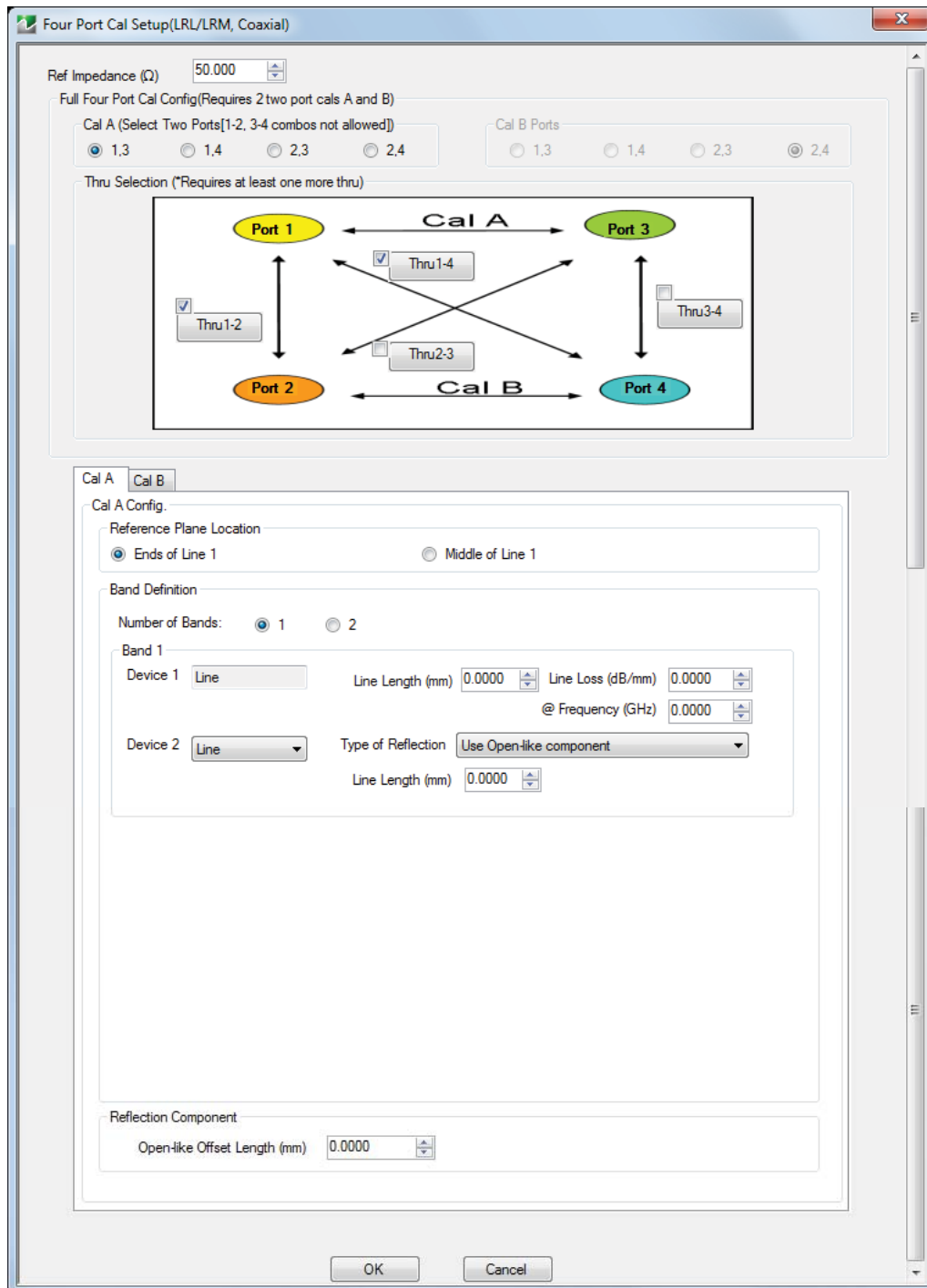


An on-wafer configuration where some line paths are more likely to be of higher quality than others. The solid lines will generally not be an issue but a transmission path illustrated by the dotted line (S-W) may be electromagnetically compromised at higher frequencies.

**Figure 16-16.** On-Wafer Line Path Quality

## 4-Port LRL/LRM Calibrations

The configuration dialog for 4-Port LRL/LRM calibrations is shown in the figure below (Figure 16-17). Note how the primary LRL/LRM ports are defined and how additional information may be required for the continuation lines. The two 2-Port calibrations are defined on the two tabs labeled Cal A and Cal B. Each tab alone looks the same as the two port LRL/LRM calibrations discussed in earlier chapters. Note that on the actual display all of the information may not be visible and a scroll bar may be required.

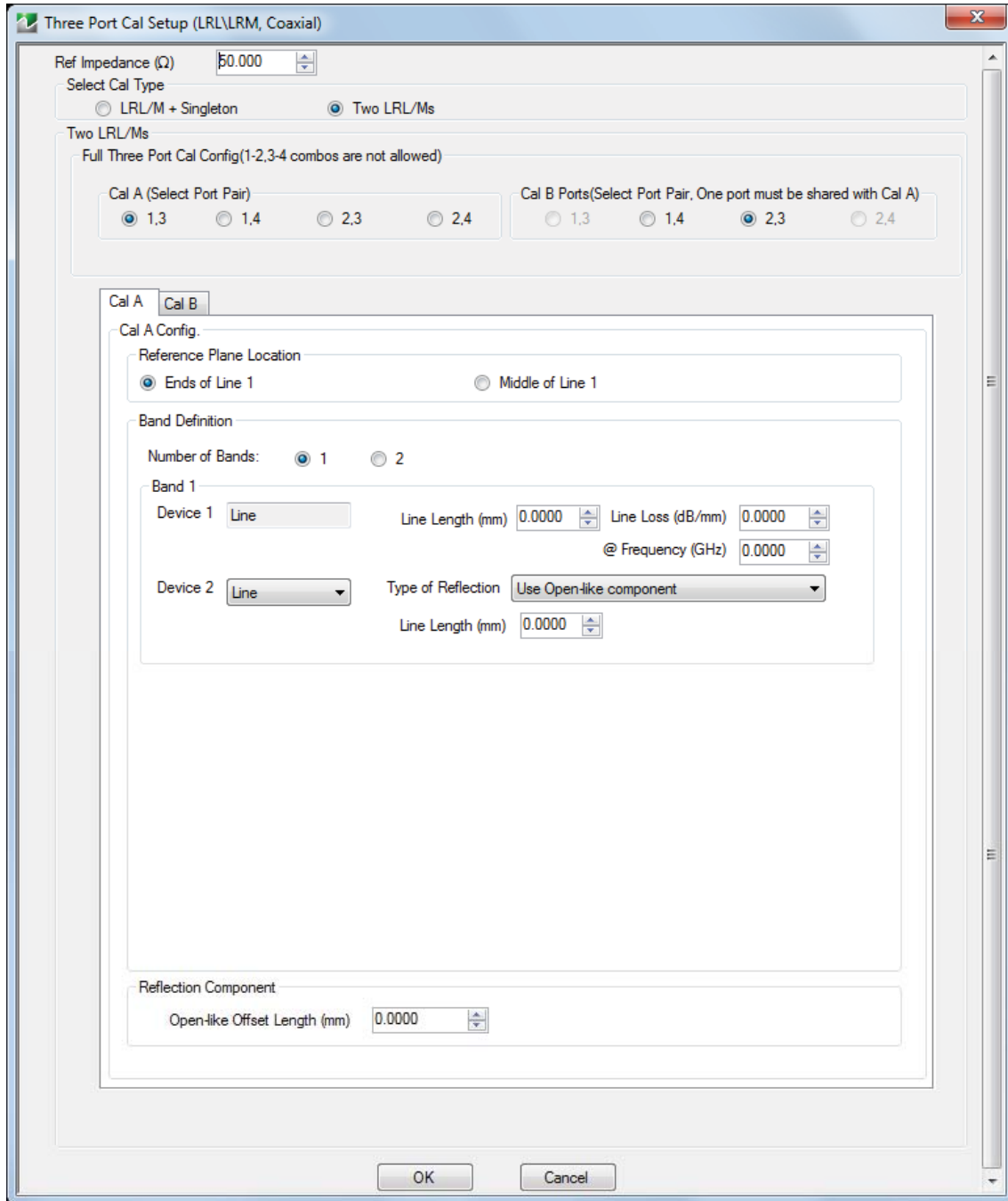


The modify calibration dialog for 4-Port LRL/LRM calibrations is shown here.

**Figure 16-17.** FOUR PORT CAL SETUP (LRL/LRM, COAXIAL) Dialog Box

### Three Port LRL/LRM Calibration

Much like the 4-Port LRL/LRM calibration, the 3-Port version is constructed from a pair of 2-Port LRL/LRM calibrations (unlike the defined-standards approaches). Obviously there is going to be port overlap. The first calibration will define the port reflectometer parameters on the overlap port. The modify calibration dialog for this situation is shown below (Figure 16-18).

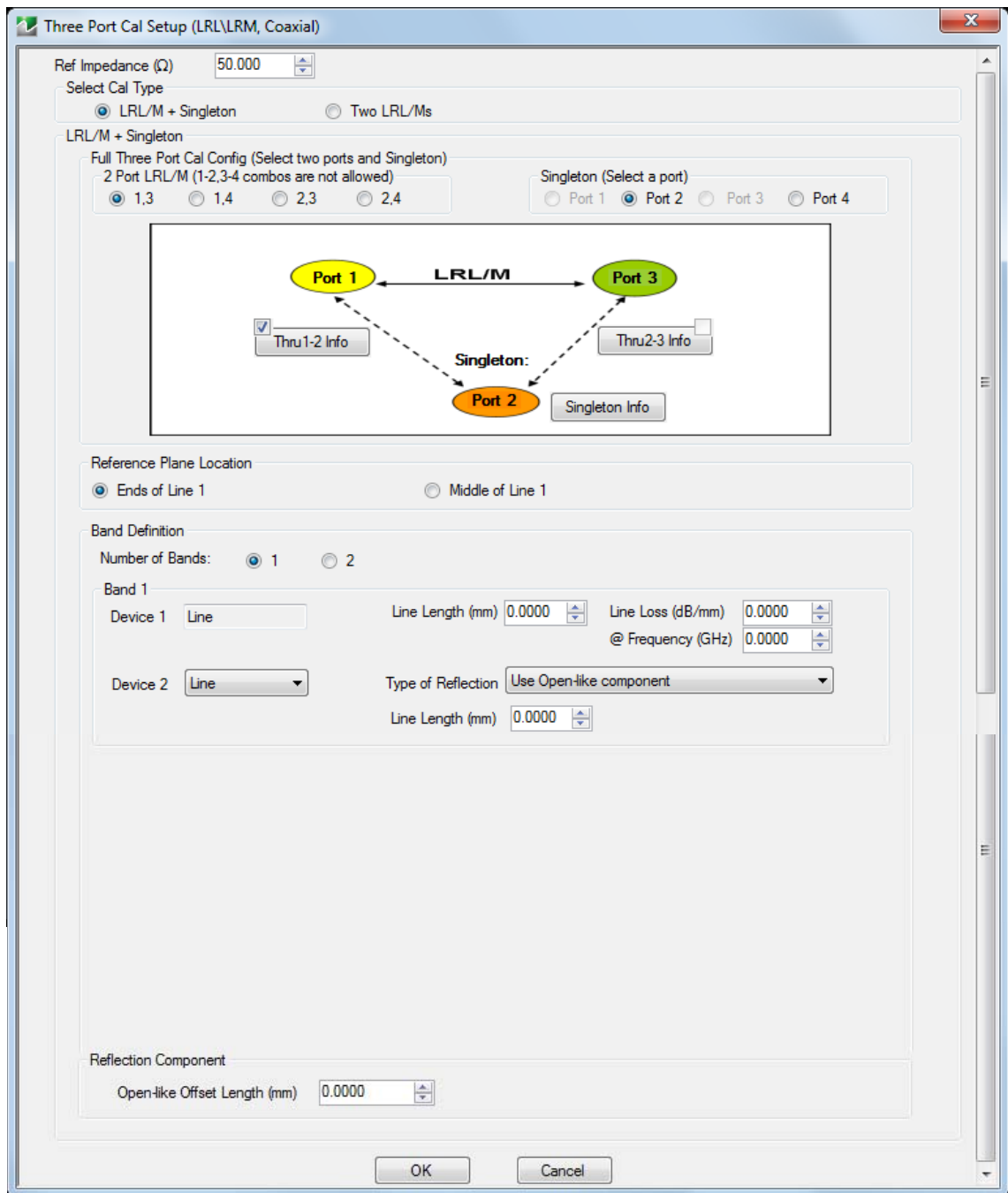


The modify calibration dialog for the three port LRL/LRM calibration is shown here for the case of a single LRL/LRM step plus a single through line completion step.

**Figure 16-18.** THREE PORT CALSETUP (LRL/LRM, COAXIAL) Dialog Box - Two LRL/Ms - Cal A Tab

The 2-Port calibration situation for LRL/LRM is similar to that shown for the defined-standards case: it is allowed to perform two of these calibrations in parallel. Aside from the additional definition required, the approach is the same as discussed in an earlier chapter.

This 3-Port calibration can also be constructed from a single 2-Port LRL/LRM cal together with a singleton definition, as shown in [Figure 16-19](#). The single LRL/LRM cal must be defined as usual and the one or two extra throughs must also be defined as before.



**Figure 16-19.** THREE PORT CAL SETUP (LRL/LRM, COAXIAL) Dialog Box - LRL/M + Singleton

In addition, a single defined standard must be measured at the singleton port defined under the Singleton Info button as shown below (Figure 16-20). The standard is allowed to be an open or a short and the usual offset plus inductance or capacitance polynomials are supported. The measurement of this additional standard allows one to distinguish between load match and source match at the singleton port. Note that in this case, the connections to the singleton port must be thus (reciprocals are not allowed). The interconnect is used to derive the singleton ports reflectometer behavior so that additional restriction is required.

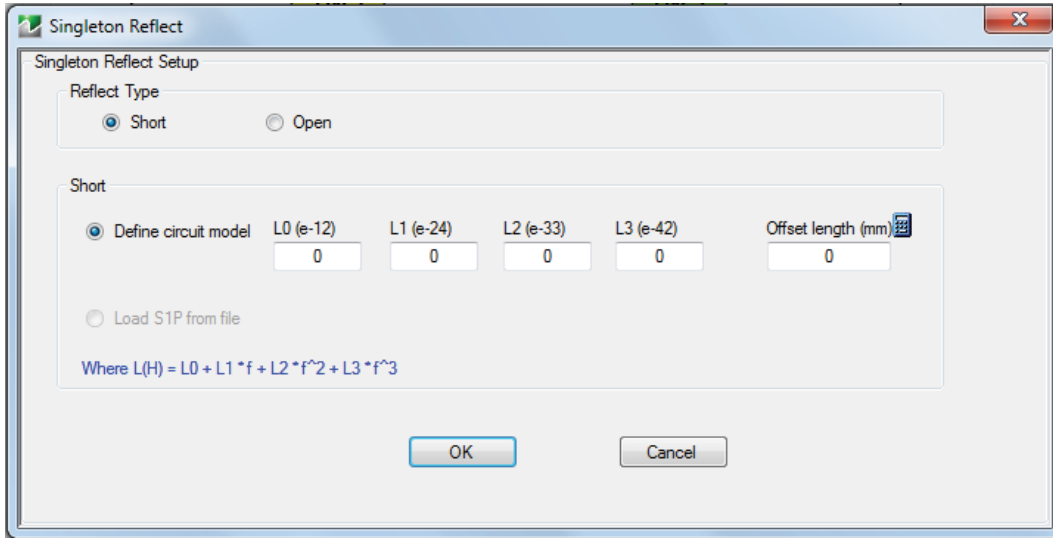


Figure 16-20. SINGLETON REFLECT Dialog Box

The calibration steps are a bit different for this type of calibration and the step menu is shown below (Figure 16-21). The extra singleton button reflects the asymmetric nature of the information required from this port.

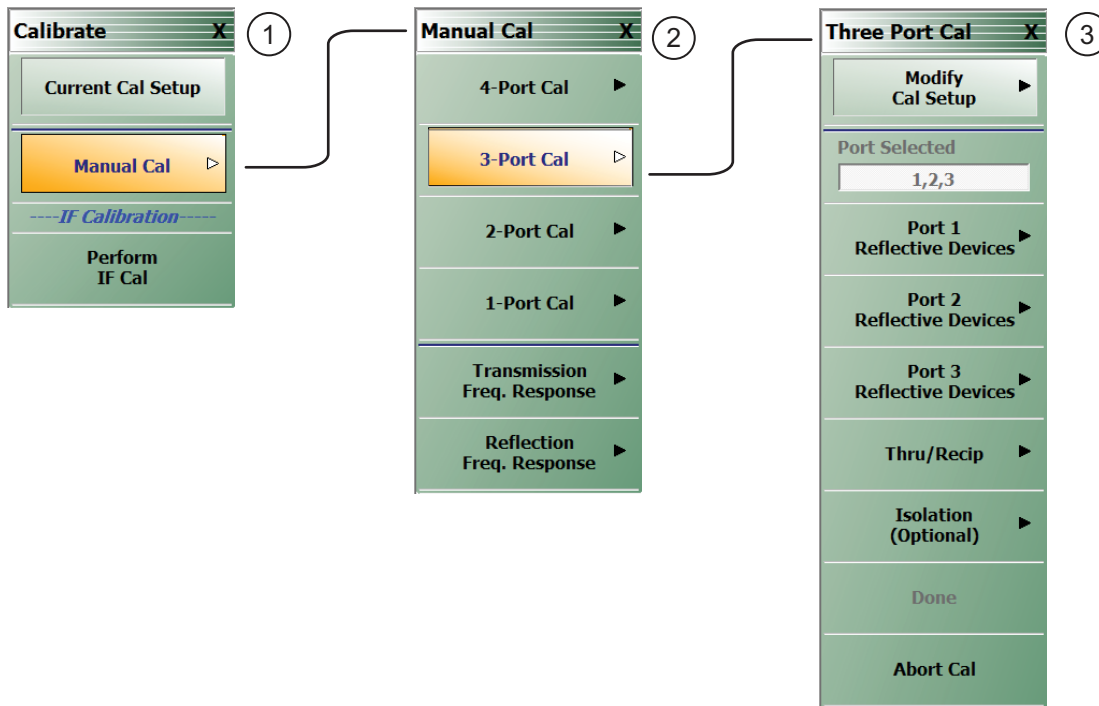


Figure 16-21. THREE PORT CAL Menu - LRL/LRM - Coax - One LRL/M + Singleton



## 16-6 Uncertainty

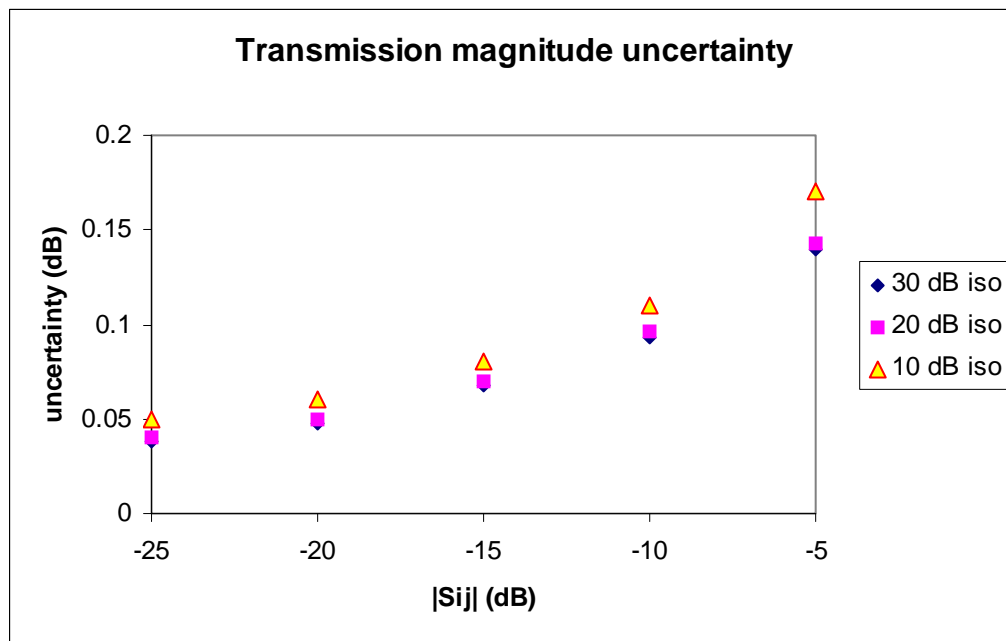
The uncertainties in the 4-Port measurement itself are straightforward extensions of those derived from the two port model. Associated with each port are residuals due to source and load match, directivity, and reflection tracking. Between every pair of ports is a residual due to transmission tracking. Other terms due to isolation and repeatability are often ignored in the analysis. The only real difference from a two port model is that there are multiple load match terms and each is dependent on path isolation (e.g., [7], section III. A). From the point of view of classical error models, one can simulate these effects with an elevated effective load match in many cases.

As an example, consider the measurement of  $S_{11}$ . The primary factors affecting this measurement (ignoring noise floor and compression effects) will be residual directivity errors ( $\Delta ed1$ ), source match errors ( $\Delta ep1S$ ), reflection tracking ( $\Delta et11$ ) and load match ( $\Delta epnL$ ). This simplified analysis also ignores multiple reflections between a series of ports since they will be at most 2<sup>nd</sup> order effects.

$$\text{err} \approx \Delta ed1 + S_{11} \cdot \Delta et11 + S_{11}^2 \cdot \Delta ep1S + S_{21}S_{12} \cdot \Delta ep2L + S_{31}S_{13} \cdot \Delta ep3L + S_{41}S_{14} \cdot \Delta ep4L$$

### Equation 16-14

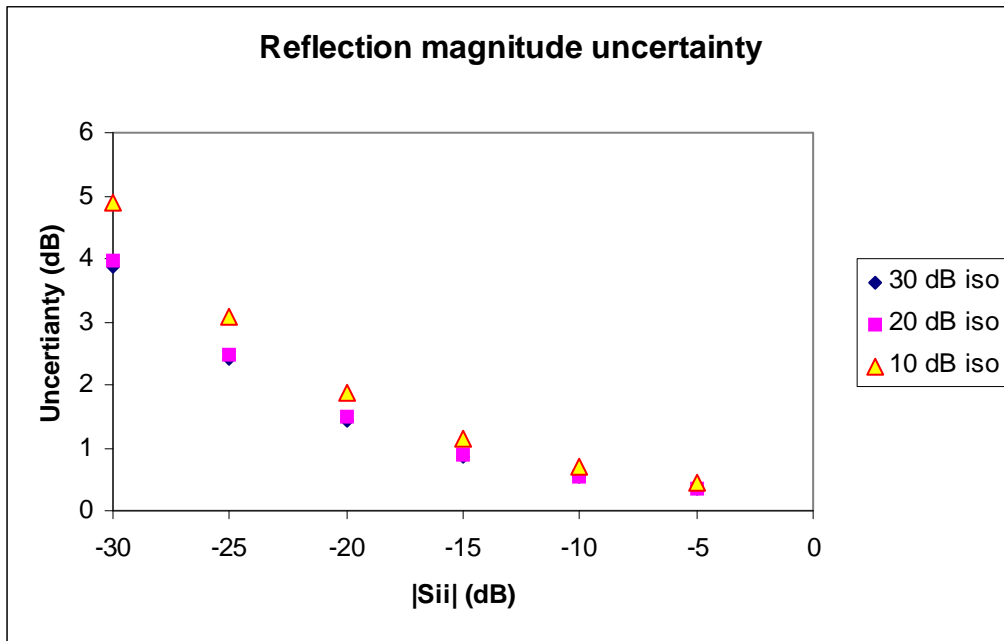
Clearly if some of the transmission terms are small, the load match quality becomes less important as observed before. Some curves are shown below (Figure 16-22 and Figure 16-23) to illustrate this dependence on isolation. These are based on calibration residuals characteristic of a reasonably high quality calibration but the main intent of the curves is to display tendencies. The transmission curve of Figure 16-22 shows little effect until the isolation gets to between 10 and 20 dB. The greatest impact will be for devices of low insertion loss (right side of the curve) as might be expected.



The dependence of transmission magnitude uncertainty on the loss in the desired path and the isolation to the other ports is shown here.

**Figure 16-22.** Transmission Magnitude Uncertainty

The reflection curves of [Figure 16-23](#) show a similar qualitative dependency on isolation and a worsening of the relative effect as the desired return loss gets larger. Combining the two figures, it is clear that the worst case scenario is a low insertion loss, high return loss path with poor isolation to the remaining ports. This makes intuitive sense since this situation provides a maximum number of interfering standing waves within the device.



The dependence of reflection magnitude uncertainty on the reflection at the desired port and the isolation to the other ports is shown here.

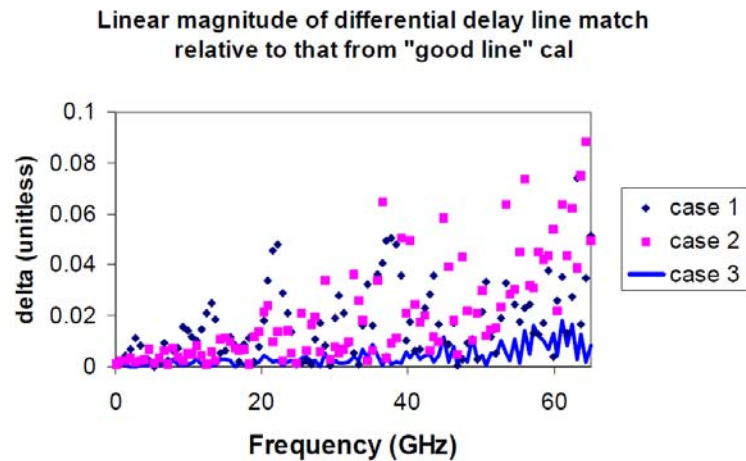
**Figure 16-23.** Reflection Magnitude Uncertainty

The exact configuration of the through selections will have some impact on uncertainty as well. If one uses redundancy heavily, some of the previous calibration results (which have their own uncertainty) are used to compute other transmission tracking terms (thus elevating their uncertainties). Thus there is something of an uncertainty penalty in taking advantage of redundancy to reduce calibration time. Depending on the nature of the available throughs between some ports (electromagnetically questionable), however, there may be even more of a penalty in trying to use all of the throughs if they are of low quality. If the calibration is of reasonably high quality, the transmission tracking penalty in using redundancy will normally not exceed a few hundredths of a dB but each calibration situation can be different.

The heavy use of reciprocals in lieu of throughs can also affect uncertainties since the accuracy on load match acquisition is lower using reciprocals. Again, trying to treat the networks as throughs may make it even worse so there is an additional trade-off in play. If the reciprocal loss is under 5-10 dB and its return loss is better than about 10 dB, the uncertainty penalty will be small except for measurements of very low loss, high return loss devices (which if they existed, why were they not used as the reciprocals?).

The plot below ([Figure 16-24 on page 16-29](#)) illustrates some of these complex trade-offs. The DUT in all cases is a differential delay line and we are interested in measuring its return loss. There are two high quality throughs available during the cal (return loss >30 dB) but the other available lines have a 15 dB return loss. The error relative to the correct return loss (in linear units) is being plotted.

- **Case 1 (not done)** – Use the poor line to establish load match and treat it as a through.
- **Case 2 (can be done)** – Use the good lines to get load match but treat the poor line as a through to get the remaining transmission tracking terms
- **Case 3 (preferred)**: Treat the poor line as a reciprocal.



An example of the effects of through and reciprocal selection on measurement uncertainties is shown here.

**Figure 16-24.** Measurement Uncertainties for Through and Reciprocal Selection

In this case, using a reciprocal gives a far better result than trying to force a “through” utilization.

### Uncertainty of Derived Mixed-Mode S-Parameters

Uncertainty of derived mixed-mode S-parameters is another issue of interest. Since the mixed mode terms are simple linear combinations of the normal S-parameters, the uncertainty in a mixed-mode parameter is easy to compute:

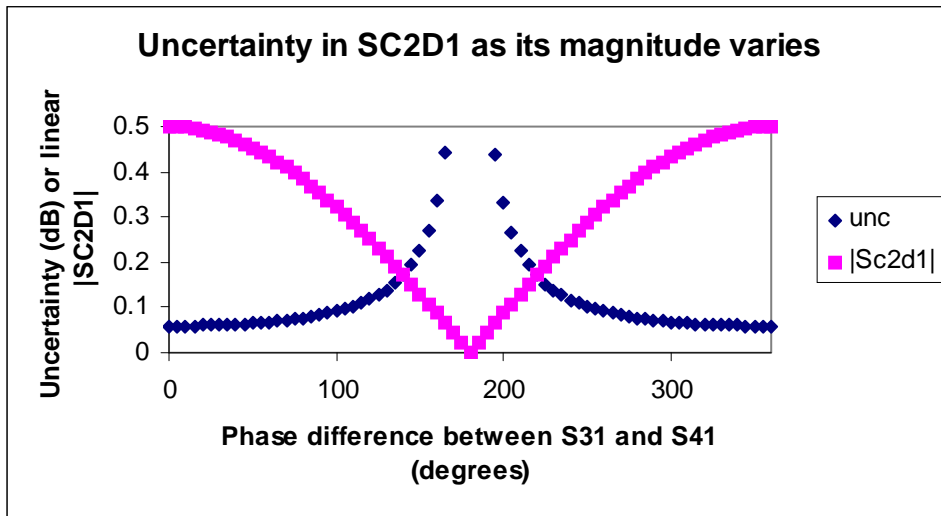
$$S_{c2d1} = \frac{1}{2} (S_{31} + S_{41} - S_{32} - S_{42})$$

**Equation 16-15**

$$\frac{\Delta S_{c2d1}}{S_{c2d1}} \leq \frac{|\Delta S_{31}| + |\Delta S_{41}| + |\Delta S_{32}| + |\Delta S_{42}|}{S_{31} + S_{41} - S_{32} - S_{42}}$$

**Equation 16-16**

Where linear absolute magnitudes can be used for a worst case computation. The caveat here is that this is in linear terms while uncertainties are often more useful in a log form. This has a surprising effect for some parameters. As an example, consider the case where the single-ended uncertainties are fixed at 0.03 dB,  $S_{32}$  and  $S_{42}$  are zero and  $S_{31}$  and  $S_{41}$  are allowed to vary. For the purposes of an example, the magnitude of  $S_{31}$  and  $S_{41}$  will be fixed at 0.5 and the phase will be allowed to vary. As one can see in [Figure 16-25 on page 16-30](#), when the phase of the single ended parameters is such that  $|S_{C2D1}|$  is small, the uncertainty (in dB terms) explodes. This follows since the numerator is largely fixed but the denominator can get small.



The uncertainty (in dB) in a mixed-mode parameter is a strong function of the magnitude of that parameter because of how they are computed.

**Figure 16-25.** SC2D1 Uncertainty in SC2D1

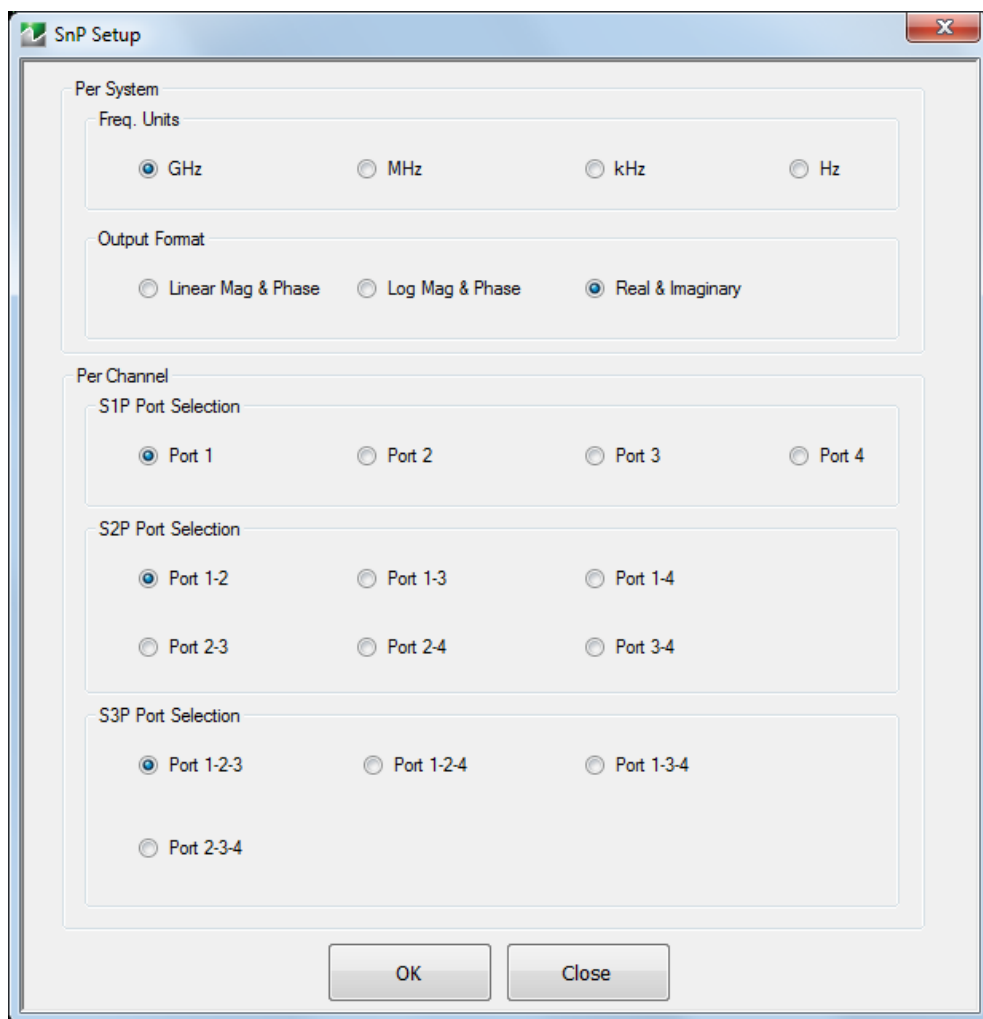
Since the desired quantity ( $S_{c2d1}$  in this case) is very small, the relative uncertainty can be quite high. This is somewhat intuitive since the computation is subtracting nearly equal numbers. The user is therefore cautioned that cal stability will be extremely critical on the smaller mixed mode parameters and the uncertainties will be relatively high. The biggest source of problems will often be cable changes with flexure or connector repeatability.

## 16-7 Saving SNP Data Files

While saving a .s4p file seems very natural with a four port structure, the saving of .s2p and .s3p files raises some questions (such as, which ports?) as does the desire to save possible mixed-mode parameters in the same file format.

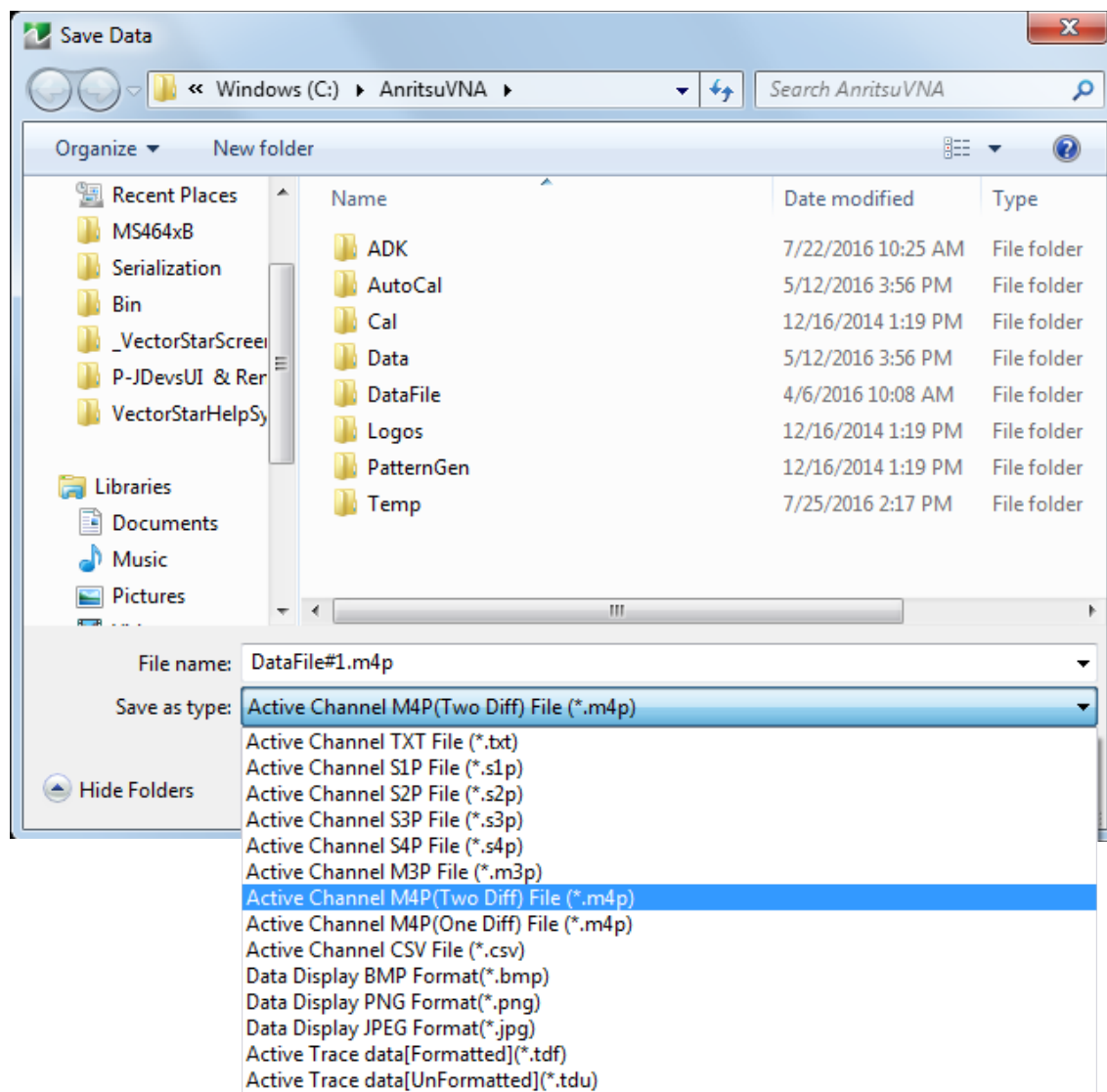
The .snp setup menu (see [Figure 16-26](#)) helps in the matter of which ports are used for the lower order files. Since the system cannot know which ports are necessarily of the most interest to the user (particularly when a higher order calibration is applied), the pair or triplet to be saved must be specified on this menu. Of course, the port used for .s1p file save must be similarly specified. If a port combination is selected that is not currently calibrated, available data for the relevant parameters will be saved but may not be physically meaningful. Parameters corresponding to a trace that is currently on-screen will have current data sent to the file but it will be uncorrected. If the parameter is not currently displayed, data in an existing buffer will be saved but that measurement may have occurred previously.

As with .s2p files discussed earlier, the data format may also be specified on this menu.



**Figure 16-26.** The SnP SETUP dialog.

For mixed-mode parameters, another file save option is available: .mNp. The text file format is exactly the same as for the .sNp format but mixed mode parameters are used instead. The row-column orientation is what one would expect from the response menu dialogs but are summarized below.



**Figure 16-27.** The file save options are shown here to include the .mNp format. Note that there are two choices for .m4p depending on if the setup is for two differential pairs or one differential pair (and two singletons).

---

.m2p:	freq	SDD	SDC	SCD	SCC
.m3p:	freq	SXX	SXD	SXC	
		SDX	SDD	SDC	
		SCX	SCD	SCC	
(where the designator X refers to the singleton port)					
.m4p (two diff):	freq	Sd1d1	Sd1d2	Sd1c1	Sd1c2
		Sd2d1	Sd2d2	Sd2c1	Sd2c2
		Sc1d1	Sc1d2	Sc1c1	Sc1c2
		Sc2d1	Sc2d2	Sc2c1	Sc2c2
.m4p (one diff):	freq	SXX	SXY	SXD	SXC
		SYX	SYX	SYD	SYC
		SDX	SDY	SDD	SDC
		SCX	SCY	SCD	SCC
(where the designators X and Y refer to the singletons)					

---

**Figure 16-28.** The .mNp parameter ordering structure is shown here.

## 16-8 Network Extraction

Following onto the discussion of [Chapter 8, “Adapter Removal Calibration and Network Extraction”](#), there are additional network extraction techniques available to help find the networks for multiport de-embedding problems. The new techniques are labeled Types E, F, and G which apply for 4-Port calibrations. The original types (Types A to D) apply for 1- and 2-port configurations as before.

- **Type E Network Extraction**

Uses a pair of full 4-port calibrations to fully extract four S2P files describing the arms of the adapter/fixture assembly. This is a complete solution but assumes the arms of the assembly are not coupled together. This is a 4-port extension of Type C.

- **Type F Network Extraction**

This is a 4-port back-to-back method where four S2P files are extracted and the four arms of the adapter/fixture assembly are assumed uncoupled. As with Type D (the 2-port equivalent), match is assigned to the outer planes. Port 2 of the .s2p files is assigned to the port nearer the DUT as is consistent with the de-embedding system operation.

- **Type G Network Extraction**

This is a 4-Port back-to-back method where two S4P files are generated and the sides are assumed coupled (in a half-leaky sense). Measured cross-coupling is assigned to the outer planes. Port assignments on type G can be complex and the examples in the text should be noted.

For both Types F and G, the inner plane through connection is assumed to be between opposite ports (1-3 and 2-4). As with all other network extraction types, reciprocity is assumed.

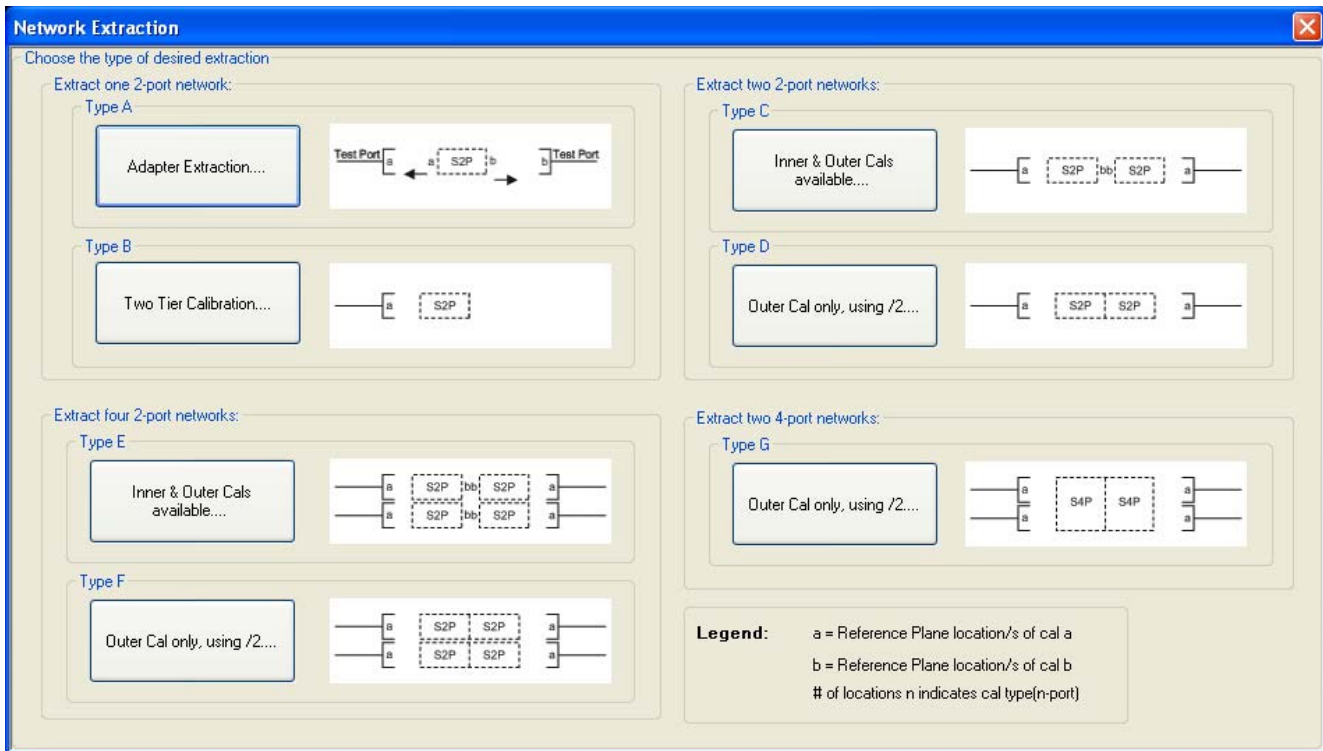


Figure 16-29.NETWORK EXTRACTION Dialog Box - Type Selection - 4-Port VNAs



## Type A Network Extraction

Before continuing with the new network extraction types, note that in the case of Type A, there is the additional requirement to specify where the adapter is (in the case of a multiport calibration). The added radio button selections are shown in the dialog below.

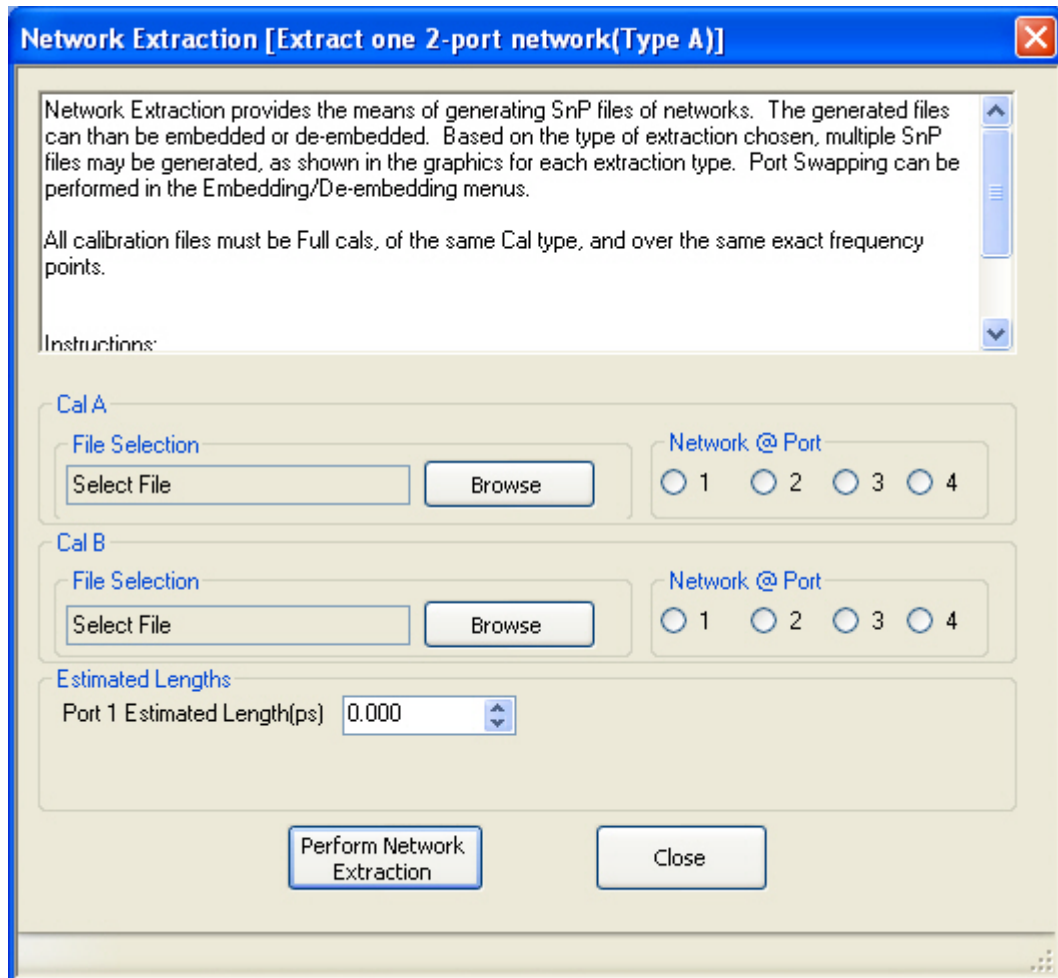


Figure 16-30. NETWORK EXTRACTION TYPE A Dialog Box

## Type E Network Extraction

In terms of execution, Type E is very much like Type C. The two full calibration files must be specified (in this case full 4-Port calibrations). Upon execution, a dialog will appear allowing one to name the four S2P destination files. The files will be listed in order of absolute port number.

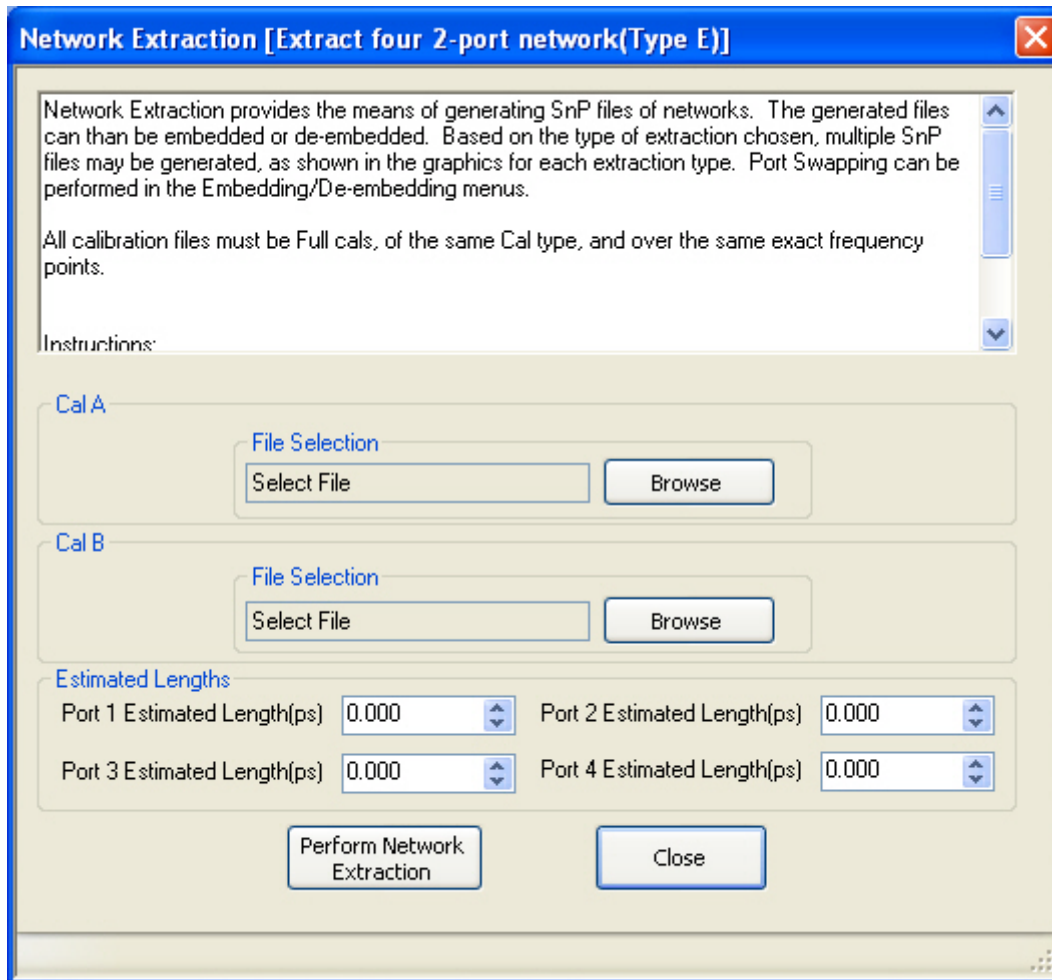


Figure 16-31.NETWORK EXTRACTION TYPE E Dialog Box

As suggested by the overall network extraction dialog, the Type E method treats the fixture as having four, uncoupled, 2-Port arms as shown below (Figure 16-32). These networks are then extracted as S2P files obviously. The required level of “uncoupling” depends on expected uncertainties and other losses in the networks. If the main paths were of very low loss and there was about 40 dB of coupling between arms of the fixture, there could be an added uncertainty of about 0.1 dB from ignoring that coupling with this method. If the coupling was actually 20 dB, there could be  $\cong 1$  dB of added uncertainty.

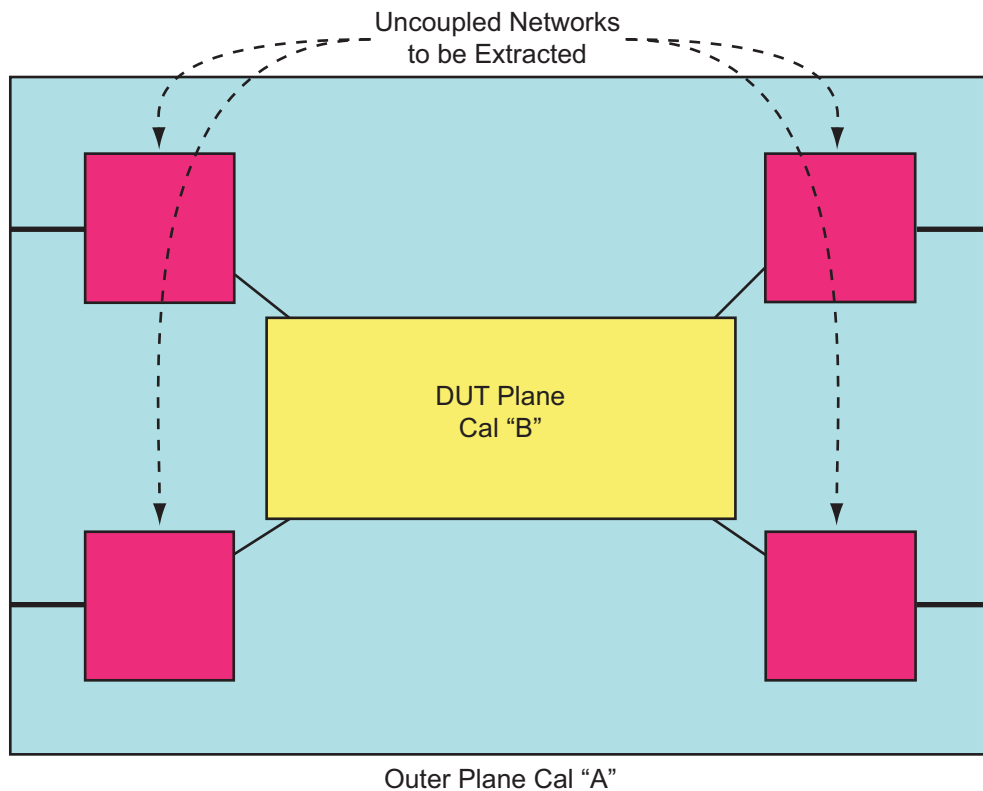


Figure 16-32. Type E Network Extraction - Uncoupled Networks To Be Extracted

## Type F Network Extraction

Types F and G operate much like Type D except a full 4-Port cal should be applied upon entering the dialog instead of a full 2-Port cal. The usual file definition dialog will follow. As with Type D, the check box option allows one to zero out all match terms instead of assigning mismatch to the outer plane.

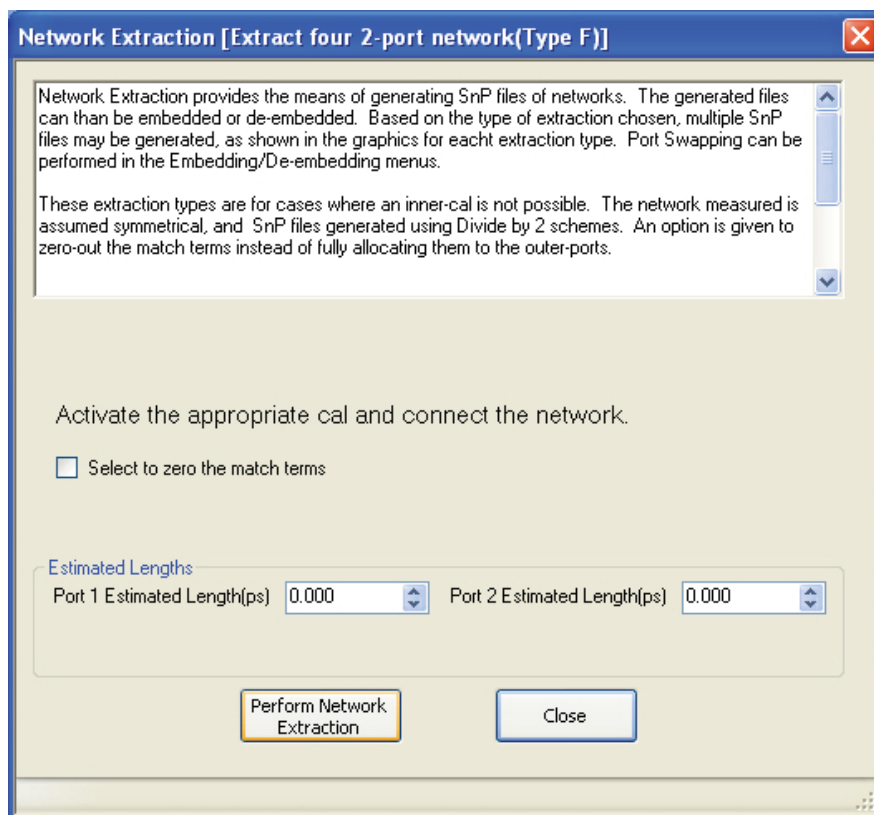
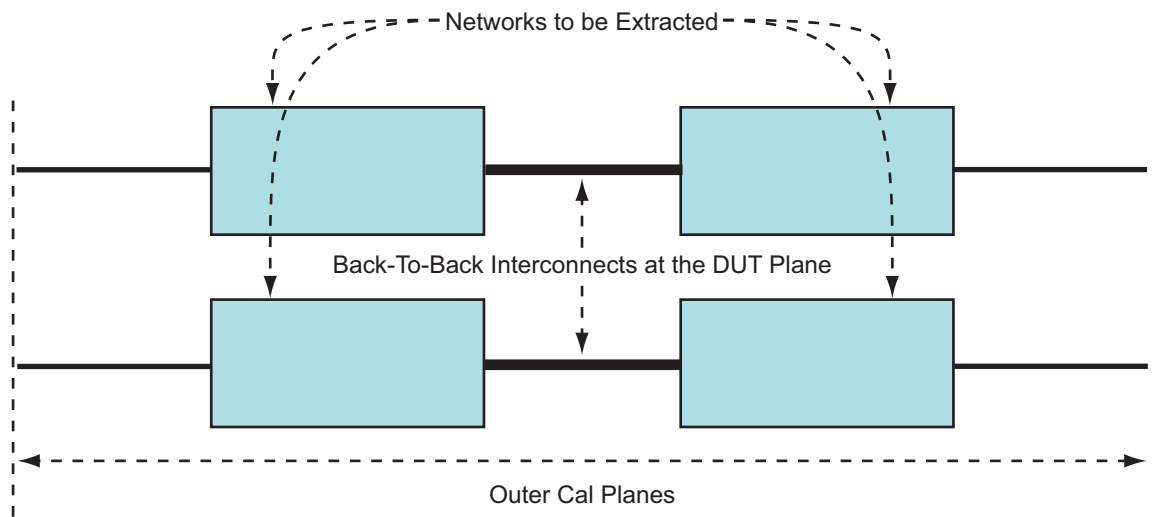


Figure 16-33.NETWORK EXTRACTION TYPE F Dialog Box

In the case of Type F, the networks are again assumed uncoupled. It is a method appropriate for the same situations as Type E except when inner calibration standards are not feasible or of reliable uncertainty. The interconnect assumed is between opposite ports (Ports 1 and 3, Ports 2 and 4) during this measurement. The port choices are not flexible in this type of extraction.



**Figure 16-34.** Type F Network Extraction - Back-to-Back Interconnects at the DUT Plane - Type F

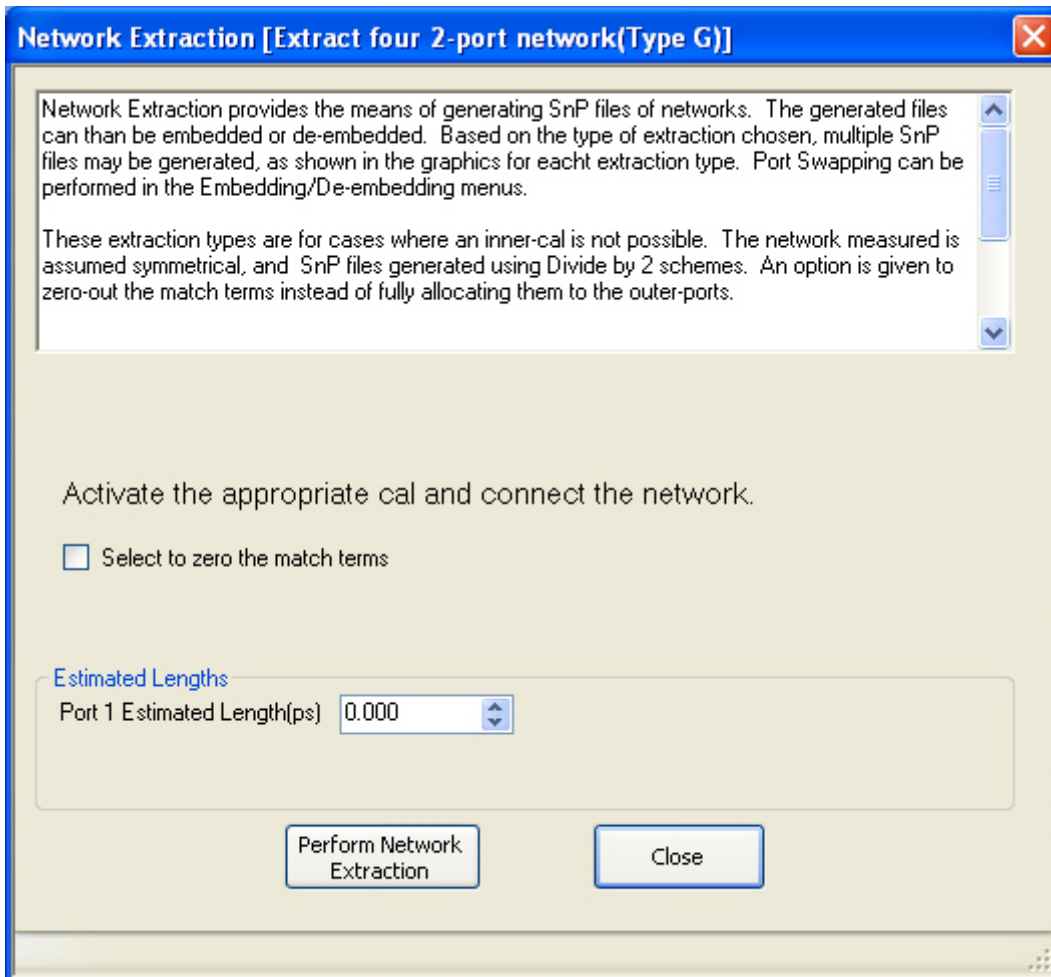
## Type G Network Extraction

In the case of Type G, the S-parameter matrix will take on a very particular form. Ports 1 and 2 of the left network are assumed to be the outer ports and the inner ports for that network will be assigned Ports 3 and 4 for the S4P definition. Because of the match and cross-coupling assumptions, the matrix saved will take on the form below (Eq. 16-17).

$$\begin{bmatrix} S_{11} & S_{12} & S_{13} & S_{14} \\ S_{21} & S_{22} & S_{23} & S_{24} \\ S_{13} & S_{23} & 0 & 0 \\ S_{14} & S_{24} & 0 & 0 \end{bmatrix}$$

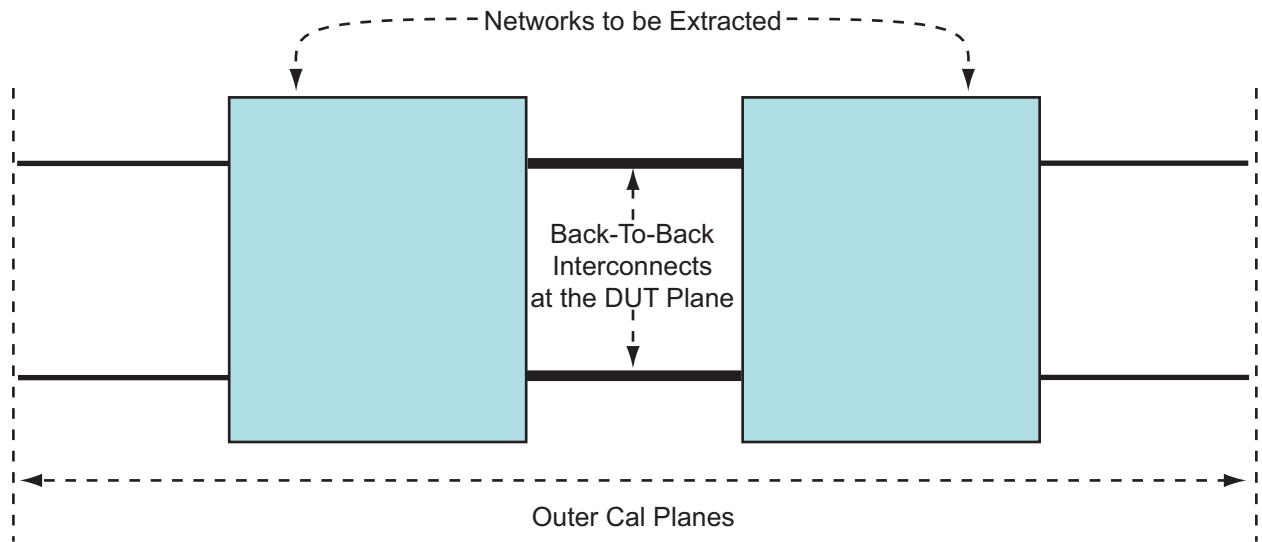
### Equation 16-17.

An eigen-structure based solution is used to split the composite results in the upper right and lower left quadrants into the two “halves”. In most cases, there should not be convergence issues with the process unless the return loss of the structure gets very close to 0 dB. As shown, reciprocity is enforced.  $S_{11} = S_{22} = 0$  if the check box is selected. The entire upper left quadrant is a direct map from the measurement as match and cross-coupling are assigned to the outer ports.



**Figure 16-35.** NETWORK EXTRACTION TYPE G Dialog Box

Structurally, the measurement is the same as in Type F. The only difference is in the matrix structure of the extracted parameters.



**Figure 16-36.** Back-to-Back Interconnects at the DUT Plane - Type G

The port assignment on type G is more complicated than that for the other types since there are not just 2 file assignment permutations but 24. Type G will always put the port pair that has port 1 in it on the outside (1-2, 1-3 or 1-4, depending on how the transmissive paths are excited) and it will do this for both files. So if the transmissive paths are 1-3 and 2-4; both files will have  $S_{33}=S_{44}=0$ .

The embedding/de-embedding engine assigns based on port pairs and assumes the files have the same port pair alignment. Since the port assignments between type G and embedding/de-embedding could be completely disjoint (since the .s4p file may have been generated with a completely different setup), some care is required. Thus if you attach a file to 1-2, then the VNA expects the file to be setup with 1-2 closest to the VNA. This is a little backward from 2 port embedding/de-embedding but the requirement is to somewhat generally handle the ambiguity if the pairs are not aligned at all. Thus when you attach a file to 3-4, the type G extracted file is usually backwards and the ports must be swapped.

## 16-9 Summary

This chapter focused on the differences in the four-port MS46524B VNA system relative to the standard two-port versions. The first part of the chapter concentrated on differences in response selection/definition and calibrations. Many of the post-processing functions from the two-port VNA carry over unchanged into the multiport measurement context. Graph types, marker readouts, and trace data readout are all trace local and will feed off the defined parameter. The same is true for time domain since this operates on any trace-level parameter, although it is not useful for an unratiod parameter such as  $b_{4/1}$ , since phase is not well-defined. Time domain, smoothing and parameter conversion apply to all of the mixed mode parameters.

## 16-10 References

1. J. Martens, D. Judge, and J. Bigelow, "Multiport vector network analyzer measurements," *Microwave Magazine*, vol. 6, Dec. 2005, pp. 72-81.
2. D. E. Bockelman and W. R. Eisenstadt, "Combined differential and common mode scattering parameters: Theory and simulation," *IEEE Trans. Micr. Theory Tech.*, vol. MTT-43, July 1995, pp. 1530-1539.
3. D. E. Bockelman, W. R. Eisenstadt, and R. Stengel, "Accuracy estimation of mixed-mode scattering parameter measurements," *IEEE Trans. Micr. Theory Tech.*, vol. MTT-47, Jan. 1999, pp. 102-105.
4. G. Sundberg, "Grasping the meaning of mixed-mode S-parameters," *Microwaves and RF*, vol. 40, May 2001, pp. 99-104.
5. J. Dunsmore, "New measurement results and models for non-linear differential amplifier characterization," *64<sup>th</sup> ARFTG Dig.*, Dec. 2004, pp. 143-146.
6. J. Dunsmore, "New methods and non-linear measurements for active differential devices," *2003 IEEE Int. Micr. Symp. Dig.*, June 2003, pp. 1655-1658.
7. J. Martens, D. V. Judge, and J. A. Bigelow, "Uncertainties associated with many-port (>4) S-parameter measurements using a four-port vector network analyzer," *IEEE Trans. Micr. Theory Tech.*, vol. 52, May 2004, pp. 1361-1368.



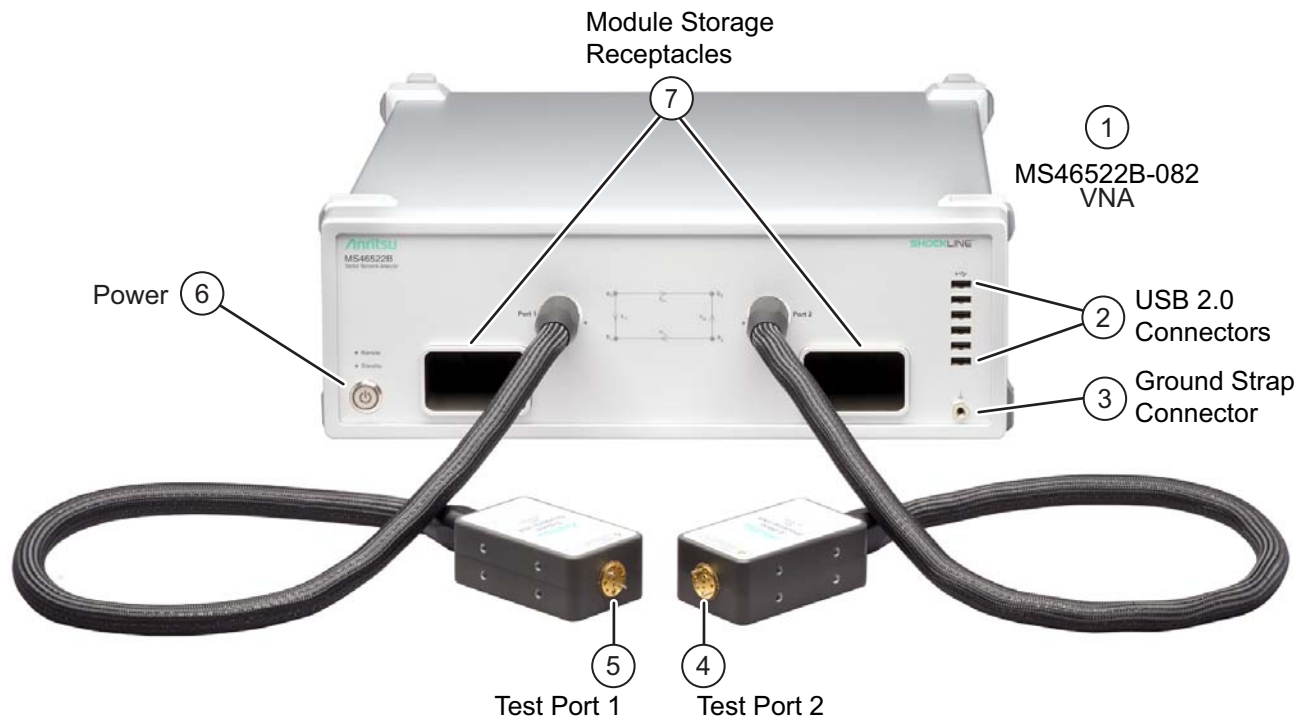
# Chapter 17 — mm-Wave Measurements (Option 82)

## 17-1 Introduction

This chapter describes the hardware control and user options that are available for the ShockLine MS46522B Performance Series VNAs employing Option 82. Calibration, measurement, and troubleshooting approaches and tips are covered.

## 17-2 Physical Setup for the MS46522B-082

The Shockline™ MS46522B-082 E-band VNA shown in [Figure 17-1](#) consists of small tethered source/receiver modules and a base chassis. The modules are attached to the chassis through one-meter cables that are permanently attached to the unit making this a compact, ready-to-use E-band VNA. The remote modules have native WR12 waveguide interface for convenient interfacing to typical waveguide devices.



**Figure 17-1.** Shockline™ MS46522B-082

### Some Things to Point Out:

- Option 082 covers the extended E-band range and major parts of the V band.
- The tethered cables are permanently attached and attempting to disconnect is not recommended.
- Waveguide interface should be covered with caps when not in use to prevent dirt and debris from entering.
- The tethered cables are flexible but can be damaged if the bend radius is too small.

## 17-3 Measurement Tips

While calibrations are covered in detail in another section of the measurement guide, there are some peculiarities relative to the mm-Wave operation that require some comment.

- The mm-Wave band is executed in waveguide thus requiring that media type selection (to take care of dispersion correction).
- SOLT/SOLR are often not recommended due to the difficulty of fabricating a reasonable open standard. An open waveguide flange radiates quite effectively and, as a result, is both unstable and has a relatively high return loss.
- SSLT/SSLR are commonly used, particularly at lower frequencies and do require a good load standard. The offset short lengths must be known with some precision.
- SSST/SSSR is quite popular, particularly at higher frequencies since a load standard is not required. Accurate knowledge of the short offset lengths is critical.
- LRL is also a popular technique and is quite effective although it can be sensitive to the condition of the waveguide flanges.



**Figure 17-2.** MS46522B-082 Tethered Module with Native WR12 Interface

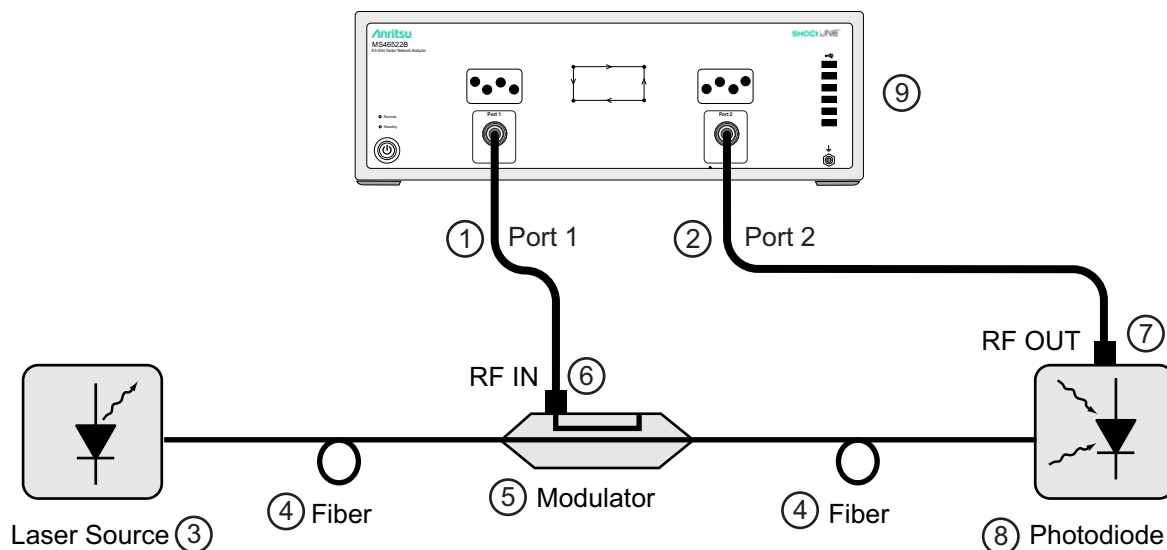
# Chapter 18 — E/O and O/E Converter Measurements

## 18-1 Chapter Overview

As fiber and free-space optical communication bandwidths increase, the need for very high speed optical modulators and detectors has also increased. The frequency response characterization of these *electrical-to-optical* (E/O, modulators sometimes integrated with lasers) and *optical-to-electrical* (O/E, detectors and receivers) converters can be important in terms of such parameters as bandwidth, flatness and phase linearity. The MS4652xB VNA has a number of measurement utilities to facilitate this kind of analysis and, coupled with the MN4765X O/E calibration module or some other calibration device, some level of measurement traceability is possible. This chapter will discuss some of the measurements of interest, setup considerations, possible measurement performance, and examples of execution procedures.

## 18-2 Introduction and Background

Conceptually, the job of the optical modulator is to place a microwave signal as modulation onto an optical carrier. Similarly, the job of the photodetector or receiver is to recover that modulation and regenerate the microwave signal. For a VNA-based measurement, both directions of conversion are required so that the processing can occur in the microwave or modulation signal domain. The result is a setup like that shown in Figure 18-1. The optical carrier is generated (usually) by a coherent laser source (which may be integrated with the modulator), modulation is applied, and then the modulation is recovered. Optical fiber is shown as the media in Figure 18-1 but it could be some other optical guiding medium or free-space in some cases. The VNA acts as a microwave stimulus (Port 1 in the figure) and receiver (Port 2 in the figure). Three and four port cases are also possible, involving multiple converters or differential ones, which will be discussed later in this chapter.



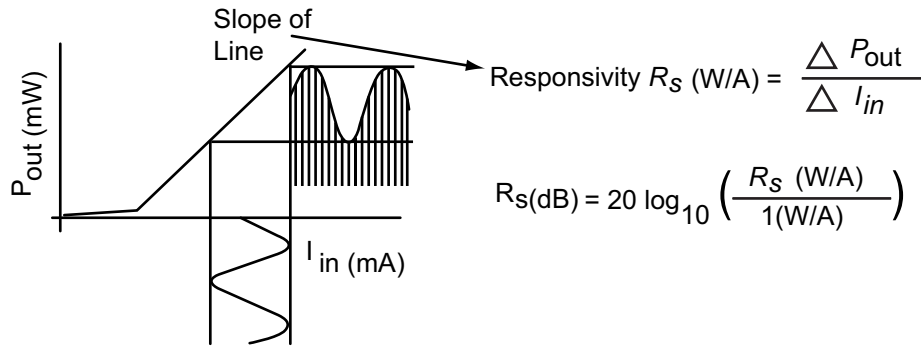
Index	Description	Index	Description
1	VNA Port 1	6	Modulator RF IN

**Figure 18-1.** A general 2-port E/O or O/E measurement setup is shown here. In some cases, the laser and modulator may be one assembly. The photodiode may be integrated with amplifiers or other components into a photoreceiver.

2	VNA Port 2	7	Photodiode RF OUT
3	Laser Source	8	Photodiode
4	Fiber	9	MS4652xB VNA
5	Modulator		

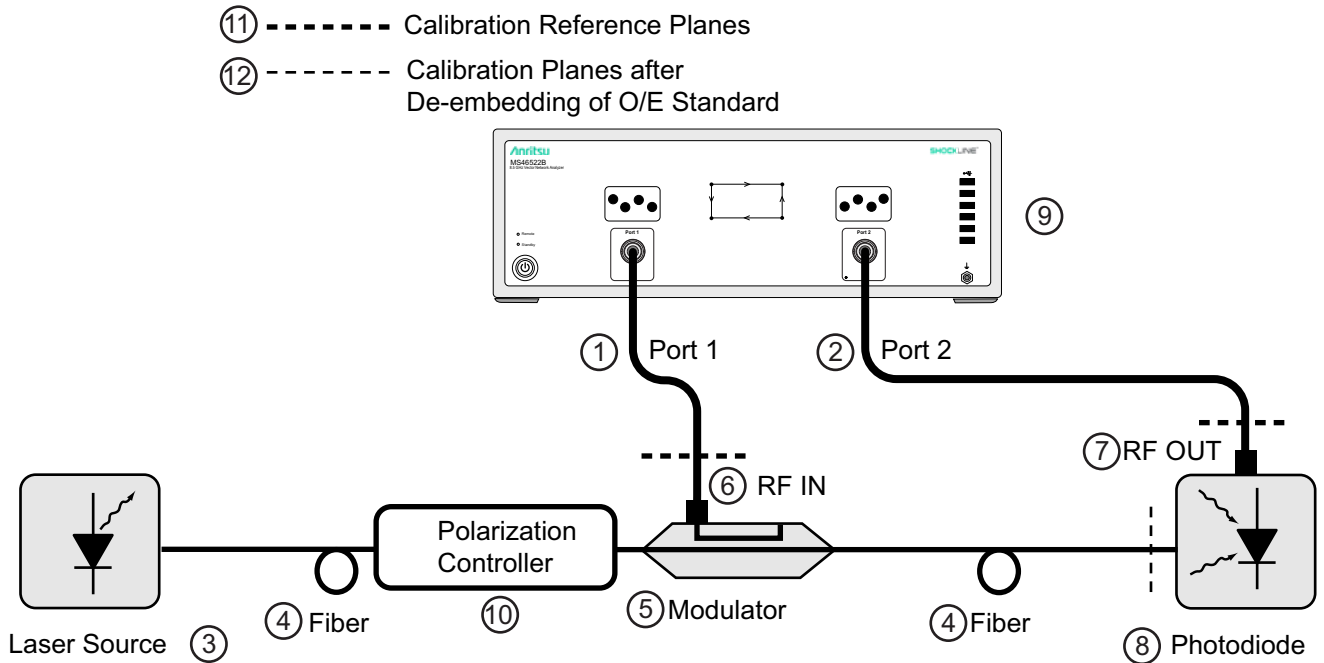
**Figure 18-1.** A general 2-port E/O or O/E measurement setup is shown here. In some cases, the laser and modulator may be one assembly. The photodiode may be integrated with amplifiers or other components into a photoreceiver.

Since the measurements results will be classed as normal S-parameters, one may wonder how these relate to the actual optical behaviors of the components. In some sense, they all become relative because the conversion between domains introduces dependencies on optical laser power, optical path losses (usually small) and other absolute shifts. Thus the real measure of conversion is essentially a responsivity slope between the optical and electrical domains as illustrated in [Figure 18-2](#). The S-parameters that appear on the instrument display for an O/E or an E/O component then represent a relative responsivity measure (in both magnitude and phase). Often, the frequency response of this quantity is of interest as that determines bandwidth and magnitude vs. frequency plot gives this information. The phase linearity and group delay are both ways of looking at the deviation from a purely linear phase function that can be an important assessment of potential phase-related modulation distortion. Return loss of the component may also be of interest but that is a purely microwave measurement.



**Figure 18-2.** The concept of responsivity is shown here. The conversion parameters of the O/E and E/O devices measured with the VNA are essentially measures of responsivity.

A next question may be how the measurements are conducted. The starting point is a two-port VNA calibration as has been discussed in earlier chapters of this measurement guide. This calibration establishes reference planes at the microwave ports of the optical devices as shown in [Figure 18-3 on page 18-3](#) (often coaxial ports but could be waveguide, in a fixture, etc.). The next step is the use of an O/E calibration device such as the MN4765X. That particular model is a wide bandwidth photodetector housed in a thermally controlled module with carefully designed bias circuitry. This module is characterized at a traceable facility using electro-optic sampling techniques (or references derived from that) so its frequency response (in magnitude and phase) is well-known with established uncertainties (e.g., [1] -[2]). If such a calibration device is the detector in [Figure 18-1](#), then its effects can be de-embedded (see the embedding/de-embedding sections of [Chapter 10, “Calibration and Measurement Enhancements”](#) in this guide for more general information) since those behaviors are known. This then moves the reference plane to the optical side of the photodiode/calibration detector as shown in [Figure 18-3](#). Now a measurement of S<sub>21</sub> will describe the loss and phase of the modulator alone (plus some effect of the fiber which will be discussed). This frequency response (magnitude and phase) gives the required performance information discussed earlier when combined with the microwave reflection measurement (S<sub>11</sub> in the diagram) of the modulator RF port that comes for ‘free’ with the calibrated VNA measurement.



Index	Description	Index	Description
1	VNA Port 1	7	Photodiode RF OUT
2	VNA Port 2	8	Photodiode
3	Laser Source	9	MS4652xB VNA
4	Fiber	10	Polarization Controller
5	Modulator	11	Calibration Reference Planes
6	Modulator RF IN	12	Calibration Planes after de-embedding of O/E Standard

**Figure 18-3.** Reference plane placement is shown here. A calibration is done in coax, waveguide, or some other electrical media and the de-embedding function, via the O/E-E/O measurement utility, of the VNA are used together with optical data to move a reference plane into the optical domain.

The following example shown in Figure 18-4 is primarily for explanatory purposes. The first plot is an example of the conversion response of a photodetector. The second plot of phase response is also shown but the linear portion has not been removed. The third plot showing group delay (derivative of phase with respect to frequency) is often a more convenient way of looking at the phase behavior.

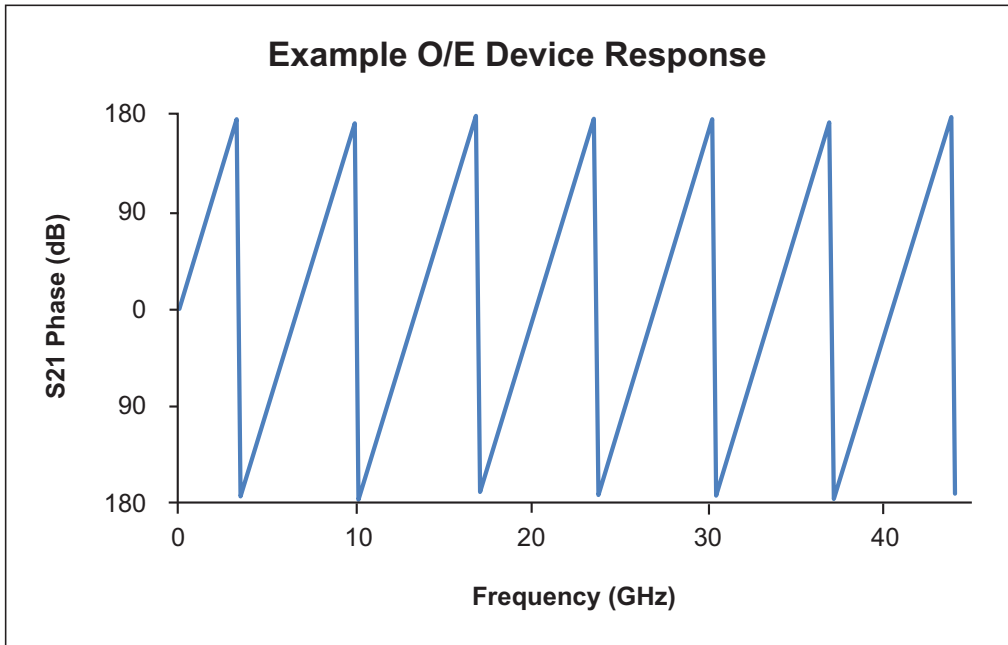
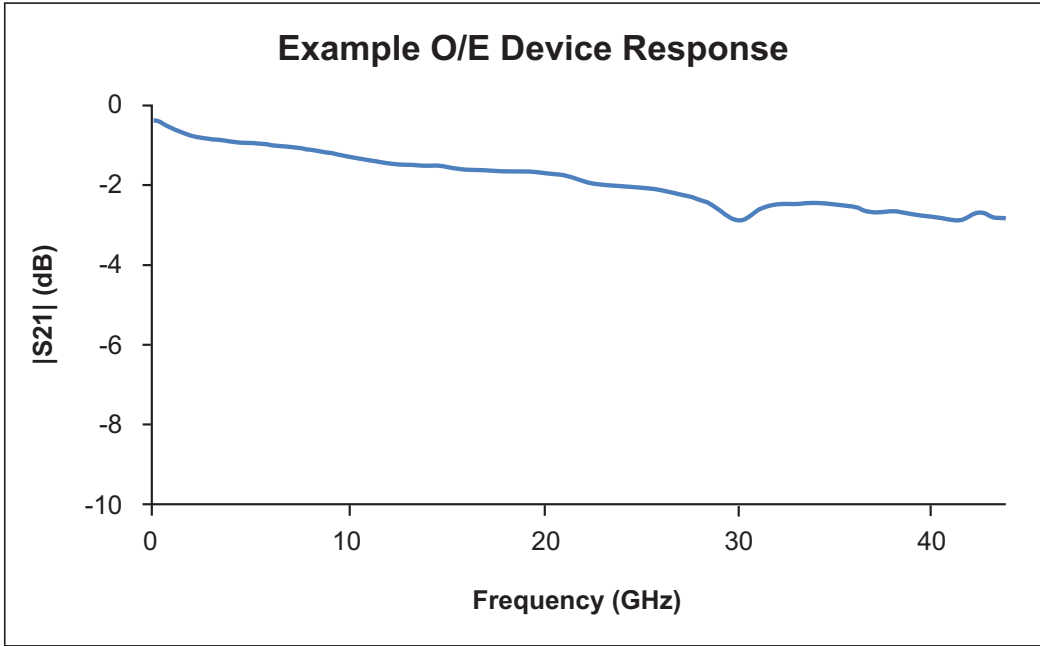
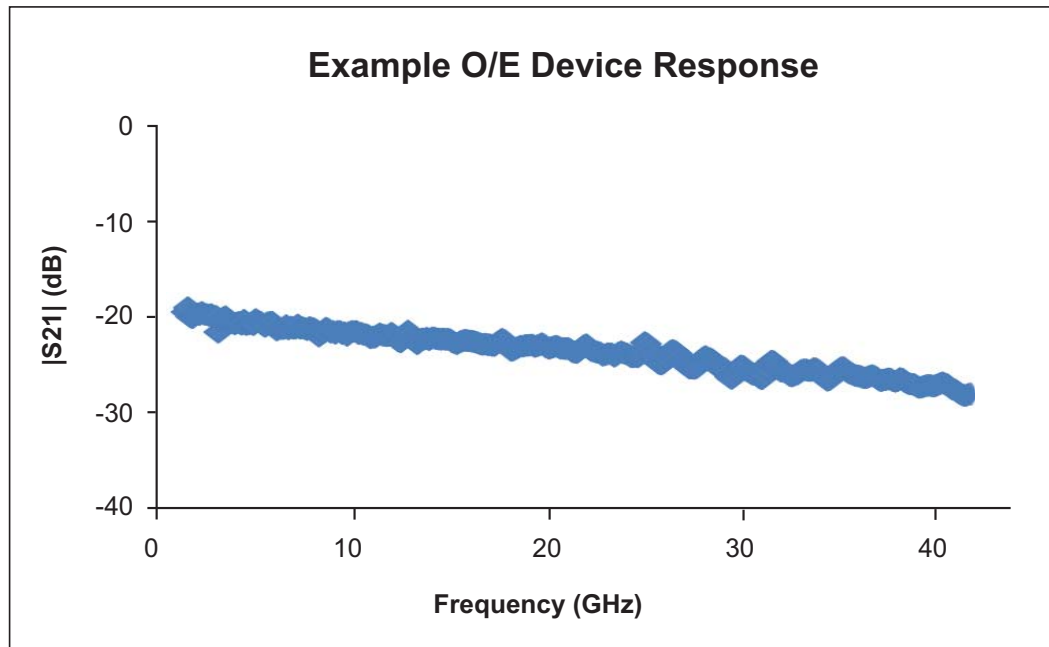


Figure 18-4. The characteristics of an example O/E device are s shown here. (1 of 2)

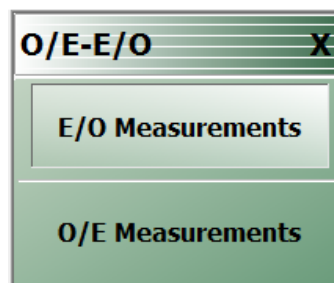


**Figure 18-4.** The characteristics of an example O/E device are shown here. (2 of 2)

If one now wanted to measure a different O/E device (not a calibration module), one could then insert that detector into the setup of [Figure 18-3 on page 18-3](#) and instead now de-embed the modulator response that was just found. In this case, because it is a second level de-embed, there may be some elevation of uncertainties that will be discussed. One could also obtain an E/O calibration device and use that instead in a one-step process.

The de-embedding (or sequential de-embedding) steps form the basis of this O/E-E/O measurement utility. The key points are controlling traceability and uncertainties throughout the process when multiple devices are being used, to control match so minimal additional artifacts are introduced, and to not try to de-embed what cannot be de-embedded. This last point is important in that inner-plane (optical) match is not known and the transmission path is unilateral anyway, so there are no multiple reflections within the DUT assembly to remove.

All of these measurement aids are available under the O/E-E/O button on the Measurements menu. As might have been guessed from the previous discussion, these approaches naturally separate based on whether the target is an O/E device (e.g., detector or receiver) or an E/O device (e.g., modulator). The menu selections, as shown in [Figure 18-3](#) delineate that choice.



**Figure 18-5.** Under the Measurements/(O/E-E/O) menu are the two selections based on which type of device is to be solved for.

## 18-3 Measurement Setups and Considerations

It is not the intent of this chapter to fully cover the optical setup details. However, some common issues and concerns will be discussed. More general information of fiber optic measurement setups can be found elsewhere (e.g., [3]-[4]).

### Optical linearity

The linearity of the characterized photodiode directly affects the accuracy of the measurement and the optical input power at which RF photocurrent will remain linear is important. One way to check that the measurement path is still linear is to normalize the S21 plot against itself and increase the optical power to see if there is a gross sensitivity. For example, set the optical laser power to 4 or 5 dBm with the setup like that of [Figure 18-1](#). Store the resulting S21 to memory (under the Display/View Trace menu) and then view DataMemMath (data divided by memory). Now increase the laser power in 1 dB steps until some compression is seen in the normalized plot on the scale of 2 dB/div. At that point, decrease the optical power level until it is out of compression. Make sure that the maximum DC current for the photodiode is not exceeded.

### Laser power and photodetector bias sequencing

Always make sure the photodiode is biased properly before turning the laser on. Improper bias or no bias can degrade photodiode performance and can also result in damage. Instructions on handling and biasing of the photodiode are shipped with the characterized photodiode accessory. Always observe ESD precautions as these devices are very sensitive to static discharge.

### Optical fiber lengths

The measurement setup will typically require optical fibers to interconnect optical components with different connectors. For example, a modulator with an FC/PC connector at the output will require an optical patch cord to adapt to the FC/APC connector on the input of the characterized photodiode accessory. Optical fibers have negligible frequency dependent loss over microwave modulation bandwidths. Thus, adding short lengths of optical patch cords to the setup does not affect the accuracy of transfer function measurements. To avoid certain polarization-related issues, it is recommended to keep the patch cord length under 10 m.



## Modulator Bias Control

Lithium niobate modulators are generally biased using a modulator bias controller (MBC) to control the operating point of the modulator. When biased in quadrature, the input RF signal linearly modulates the optical carrier. Note that when an MBC is applied, it must be designed for small signal operation. The default power from the Port 1 test port is  $-10$  dBm. This level results in a modulation depth of  $<10\%$  for many commercially available modulators. If a different model VNA or a different option configuration is being used, it may be required to drop the VNA power level from the default setting to ensure that the modulator is operating linearly. Different technology modulators may have different linearity limits so it may be required to consult the manufacturer of that device.

A DC power supply can be used in place of an MBC. However, the stability of the measurement may be degraded due to drift in the modulator's bias point.

## Connector care

It is important to establish proper cleaning procedures when connecting fiber optic devices together. Fiber optic cores are made of glass and can easily be scratched or chipped if care is not taken. The connectors found on the MN4765X are of the FC/APC type. APC (Angled Physical Contact) is chosen to help minimize back-reflection. The  $8^\circ$  angle at the end-face of the APC connector has an optical return loss of better than 50 dB. DFB lasers require large amounts of reflection isolation to function properly. The optical return loss from a common PC connector can 30 dB or worse, depending upon the polish and cleanliness of the connector.

The following are some tips to help ensure quality connections:

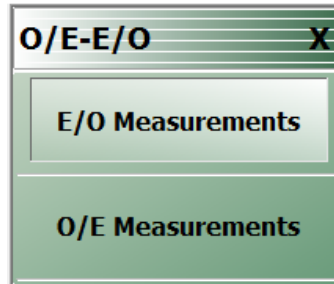
- Always clean connectors after every connection.
- Use a fiber optic scope often to ensure there are no defects on the connector end face that can cause damage to other connectors.
- Use insertable patch cords for expensive devices that require many connections.
- Always use a cloth that is free of fiberglass to clean the connectors. If necessary, use alcohol to remove stubborn dirt and oil. Thoroughly remove any alcohol residue before reconnecting.
- Avoid using any oils for connecting two cables together. Oils are messy and very difficult to clean up.
- Optical connectors do not need torque. Some connections are better when the two fibers are barely touching. Tightening the connector too much will result in higher insertion loss, more reflection, and in some cases damage to the connector.
- Always observe proper mating to APC connectors. Connecting APC to PC connectors will damage the connectors.

## 18-4 Example 2-port Procedures

With the physical setup described, the next task is really how to interface with the measurement utilities. Consider first the case of a 2-port E/O measurement where one has a characterized O/E device (such as the MN4765X). The dialog for this measurement is shown in [Figure 18-7 on page 18-9](#) (the system automatically detects if it is a 4-port configuration in which case one of the later dialogs would be displayed instead). One choice that has to be made is the port configuration. The default is to have the E/O device connected to port 1 of the VNA but this can be changed.

### Navigation to 2-Port E/O Measurement Dialog Box

Main | Measurement | MEASUREMENT | O/E-E/O | E/O Measurements



**Figure 18-6.** O/E-E/O Measurement Menu

The other major requirement is a 2-port VNA calibration. This dialog assumes that the calibration has already been done with the desired method, frequency range, etc. and saved (using **Save Setup** under the **File** menu) as a .chx file. Most of the setup parameters are obvious:

- **Frequency Range and Number of Points** (dictated by the bandwidth of the DUT among other test requirements)
- **Power Level** (this depends on the linear drive range of the modulator as discussed above and the maximum available power of the VNA, which varies with options. Generally, the higher the better within those limits for best signal-to-noise ratio)
- **IF Bandwidth and Averaging** (trade-off between measurement time and trace noise. Generally 10-100 Hz IFBW is recommended for very wideband devices since the conversion losses tend to be high and the signal-to-noise ratio is stressed). Averaging can be added for additional trace noise reduction but there is a point of diminishing returns beyond about 10 sweep-by-sweep averages or if IFBW/(pt-by-pt averages) falls below 1 Hz.
- **Calibration Method** The only requirement is that the calibration contain a transmission path that match the E/O → O/E path (anything beyond that is acceptable). Some of the choices are:

#### E/O Port = 1

Forward transmission tracking (1 → 2)

1 path – 2 port forward (1 → 2)

Full 2 port calibration

#### E/O port= 2

Reverse transmission tracking (2 → 1)

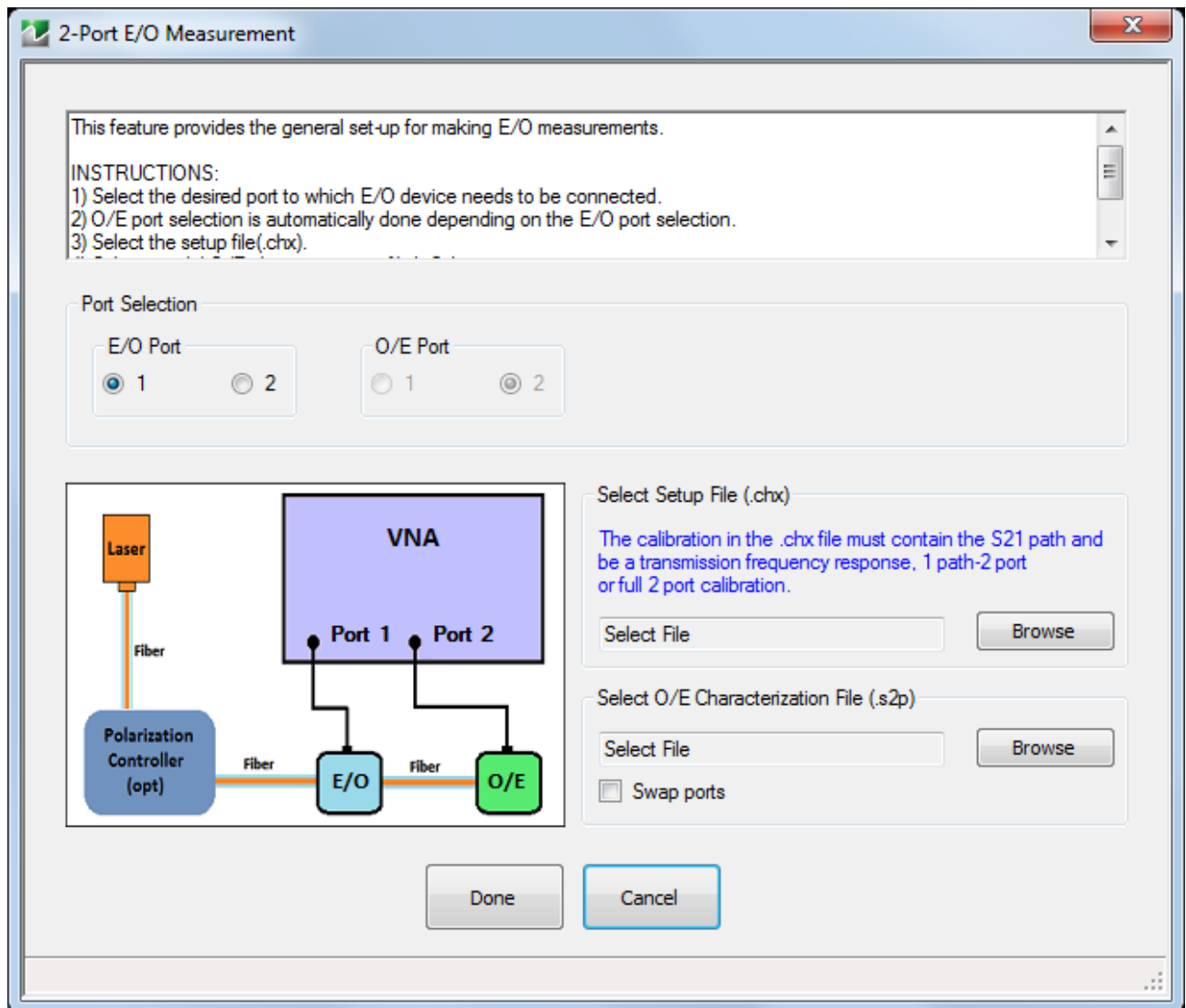
1 path – 2 port reverse (2 → 1)

Full 2 port calibration

Any calibration algorithm can be used (SOLT, SOLR, LRL, LRM, etc.) as appropriate.

Assuming this setup file is now available, it can be loaded in the dialog of [Figure 18-7](#) as can the O/E characterization file (in an .s2p file format). Note the **Swap ports** checkbox availability near the characterization portion of the dialog box. It is always assumed that the dominant path in the characterization file is the S21 parameter. If the file was constructed differently (e.g., S12 was the measurement path for the calibration device), then selecting the checkbox will force the instrument to reorder the ports in the file before processing.

When **Done** is selected on this dialog, the de-embedding is applied and the resultant calibration left on the system includes the shifted reference plane as suggested by [Figure 18-3 on page 18-3](#). This state can be saved as a new setup file (again using the **Save Setup** command under the **File** menu) if desired. Note that to go back to the non-de-embedded state, one can recall the old setup file that was just loaded in the dialog box. At this point, one can make measurements of any number of E/O devices and save the results using any of the usual techniques.



**Figure 18-7.** The dialog for 2-port E/O measurements is shown here.

The O/E measurement setup is quite similar and that dialog is shown in Figure 18-8. The difference, of course, is that an E/O characterization file must now exist. One can generate it using the previous procedure and saving the measurement result as an .s2p file or one may already have a characterization file for the E/O device. If this is not the case, a shortcut is provided to help generate an E/O characterization file with less work. This path is triggered with the Go Measure E/O button which will bring up the sub-dialog of Figure 18-9.

Assuming one has an O/E calibration device (such as the MN4765X), this Go Measure feature allows one to load that photodetector characterization file and use the setup file found on the main E/O dialog to do a quick measurement of the modulator (or assembly). The sub-dialog also has a field to save this new E/O characterization file. When completed, one can go back to the previous dialog and select Done. The resultant setup will now have the Port 1 reference plane moved to after the modulator so one can now measure any number of new O/E devices. Again, the final setup (with shifted reference planes) can be saved as can any new measurement data of the O/E devices.

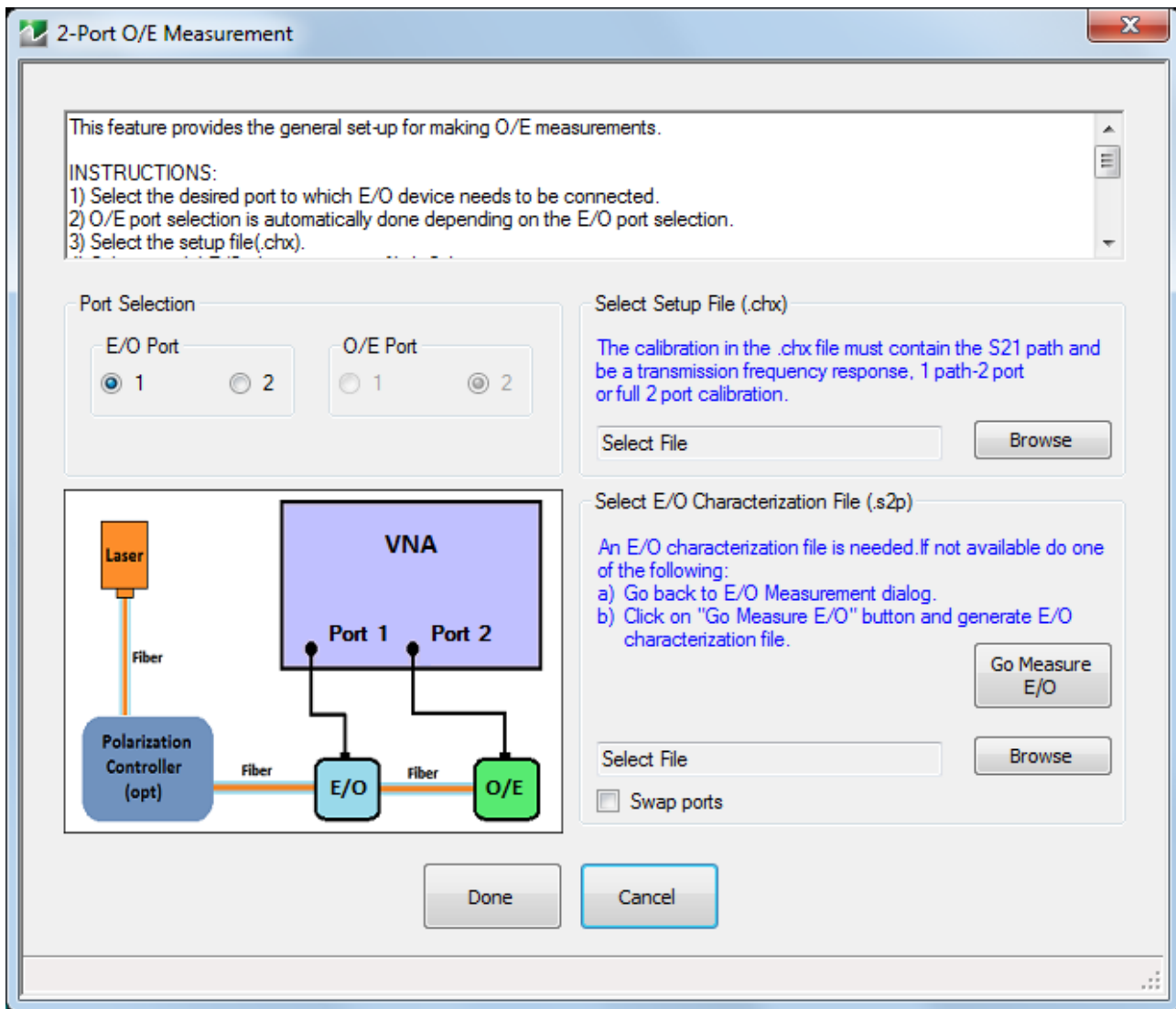
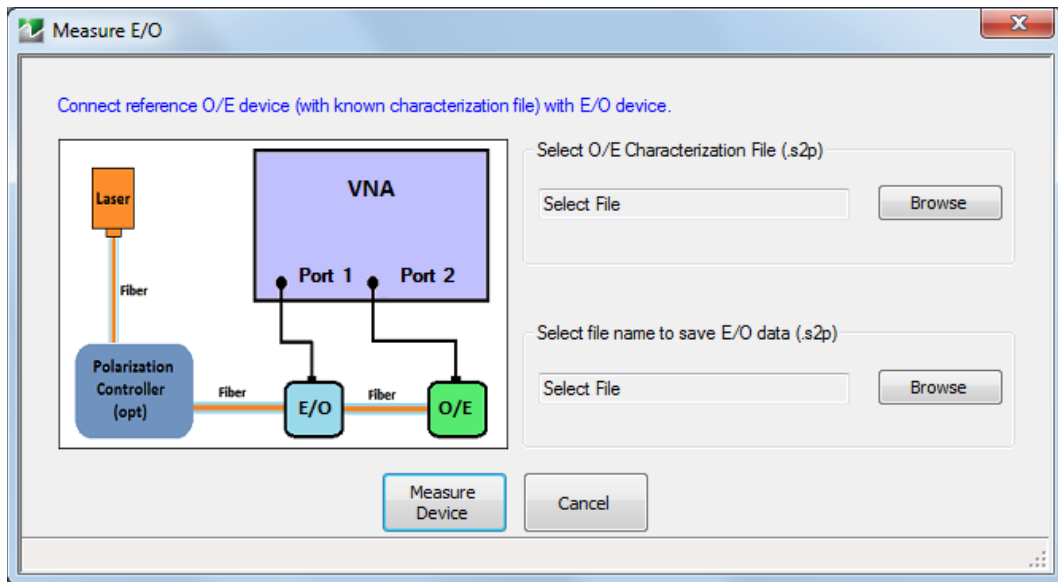


Figure 18-8. The dialog for 2-port O/E measurements is shown here.

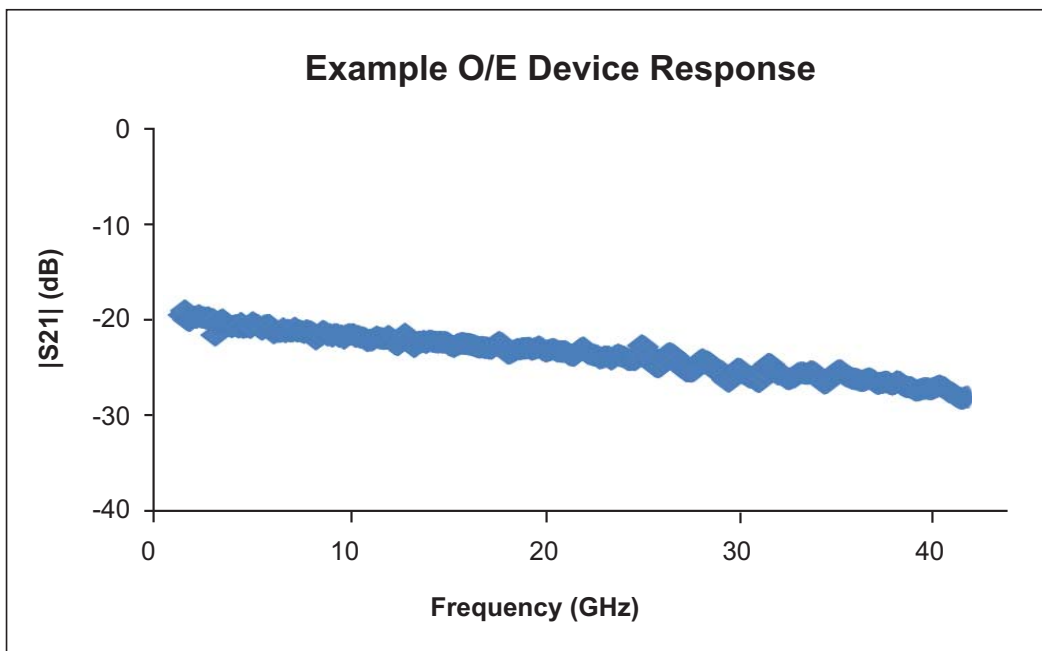


**Figure 18-9.** When measuring O/E devices, the characteristics of the E/O device must be known. If a file does not already exist, this dialog can help in doing the intermediate measurement with the help of a calibration O/E device such as the MN4765X.

**Example**

As an example, consider the following setup:

- 2 GHz to 43.5 GHz, 10 Hz IFBW, power  $-10$  dBm, no averaging.
- A full two-port SOLT calibration is performed using a 3652A Calibration Kit.
- The resulting setup file is saved as setup.chx. This setup file will include all of the above parameters including the calibration data.
- The optical assembly is hooked up with the modulator-under-test connected to Port 1 and an MN4765X O/E calibration module connected to Port 2 of the VNA. The laser is powered up after setting up bias control on the modulator and applying bias to the MN4765X (and, of course, connecting the fiber).
- The E/O measurement utility is invoked using the default port assignment, loading the .chx setup file and loading the characterization file of the MN4765X. Upon selecting Done on the dialog, the resulting S21 measurement reflects the conversion behavior of the modulator and is shown in Figure 18-10. In this case, there is about 10 dB of roll-off over the bandwidth of the measurement.



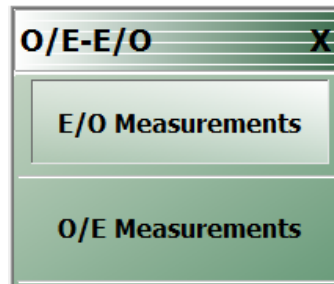
**Figure 18-10.** The results of an example 2-port E/O measurement are shown here using the procedure discussed in the text.

## 18-5 Example 4-port Procedures

With the physical setup described, the next task is really how to interface with the measurement utilities. Consider first the case of a 2-port E/O measurement where one has a characterized O/E device (such as the MN4765X). The dialog for this measurement is shown in [Figure 18-7 on page 18-9](#) (the system automatically detects if it is a 4-port configuration in which case one of the later dialogs would be displayed instead). One choice that has to be made is the port configuration. The default is to have the E/O device connected to port 1 of the VNA but this can be changed.

### Navigation to 2-Port E/O Measurement Dialog Box

Main | Measurement | MEASUREMENT | O/E-E/O | E/O Measurements



**Figure 18-11.** O/E-E/O Measurement Menu

The other major requirement is a 4-port VNA calibration. This dialog assumes that the calibration has already been done with the desired method, frequency range, etc. and saved (using **Save Setup** under the **File** menu) as a .chx file. Most of the setup parameters are obvious:

- **Frequency Range and Number of Points** (dictated by the bandwidth of the DUT among other test requirements)
- **Power Level** (this depends on the linear drive range of the modulator as discussed above and the maximum available power of the VNA, which varies with options. Generally, the higher the better within those limits for best signal-to-noise ratio)
- **IF Bandwidth and Averaging** (trade-off between measurement time and trace noise. Generally 10-100 Hz IFBW is recommended for very wideband devices since the conversion losses tend to be high and the signal-to-noise ratio is stressed). Averaging can be added for additional trace noise reduction but there is a point of diminishing returns beyond about 10 sweep-by-sweep averages or if IFBW/(pt-by-pt averages) falls below 1 Hz.
- **Calibration Method** The only requirement is that the calibration contain a transmission path that match the E/O → O/E path (anything beyond that is acceptable). Some of the choices are:

#### E/O Port = 1

Forward transmission tracking (1 → 2)

1 path – 2 port forward (1 → 2)

Full 2 port calibration

#### E/O port= 2

Reverse transmission tracking (2 → 1)

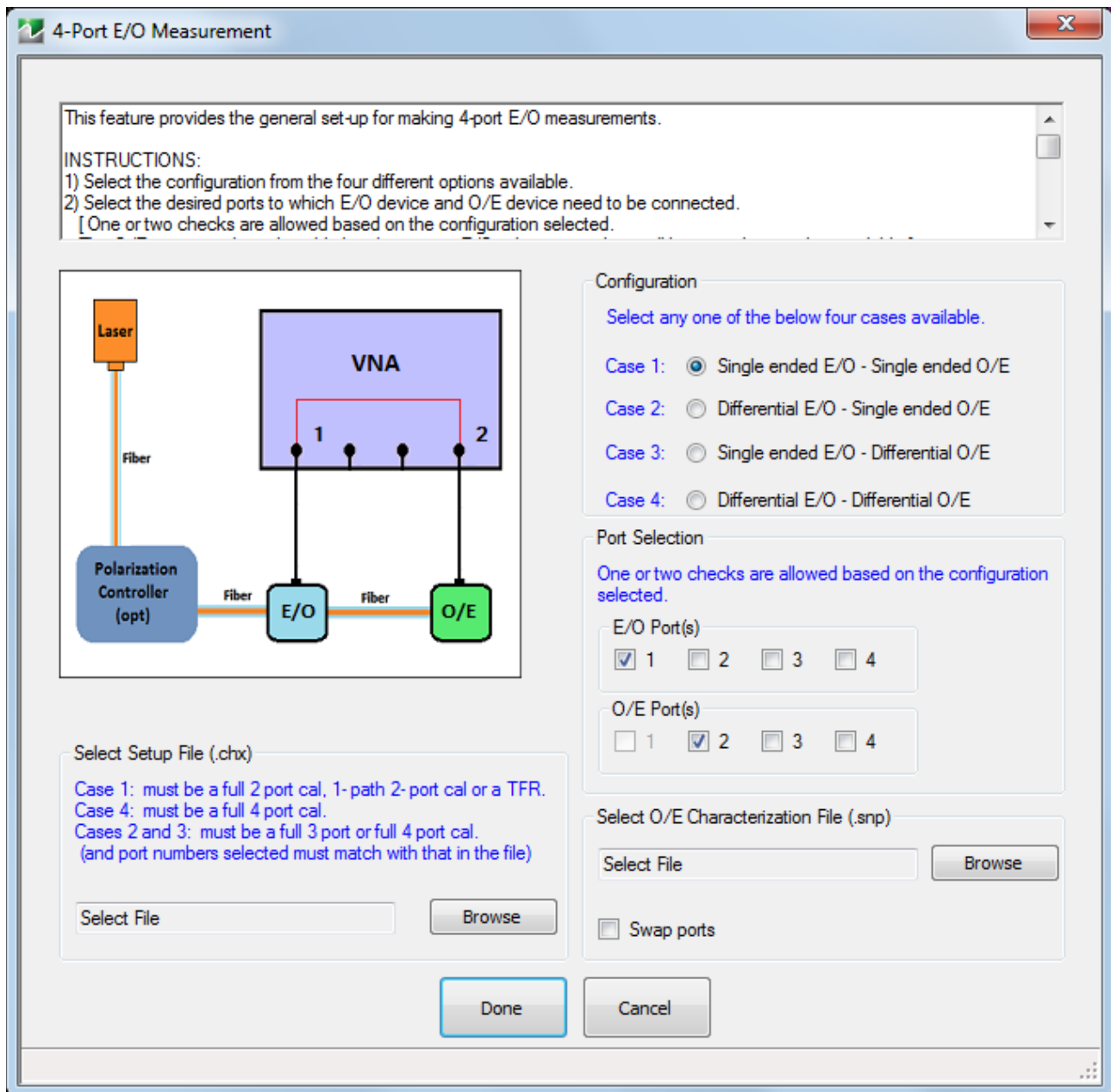
1 path – 2 port reverse (2 → 1)

Full 2 port calibration

Any calibration algorithm can be used (SOLT, SOLR, LRL, LRM, etc.) as appropriate.

Assuming this setup file is now available, it can be loaded in the dialog of [Figure 18-12](#) as can the O/E characterization file (in an .s2p file format). Note the Swap ports checkbox availability near the characterization portion of the dialog box. It is always assumed that the dominant path in the characterization file is the S21 parameter. If the file was constructed differently (e.g., S12 was the measurement path for the calibration device), then selecting the checkbox will force the instrument to reorder the ports in the file before processing.

When Done is selected on this dialog, the de-embedding is applied and the resultant calibration left on the system includes the shifted reference plane as suggested by [Figure 18-3 on page 18-3](#). This state can be saved as a new setup file (again using the Save Setup command under the File menu) if desired. Note that to go back to the non-de-embedded state, one can recall the old setup file that was just loaded in the dialog box. At this point, one can make measurements of any number of E/O devices and save the results using any of the usual techniques.

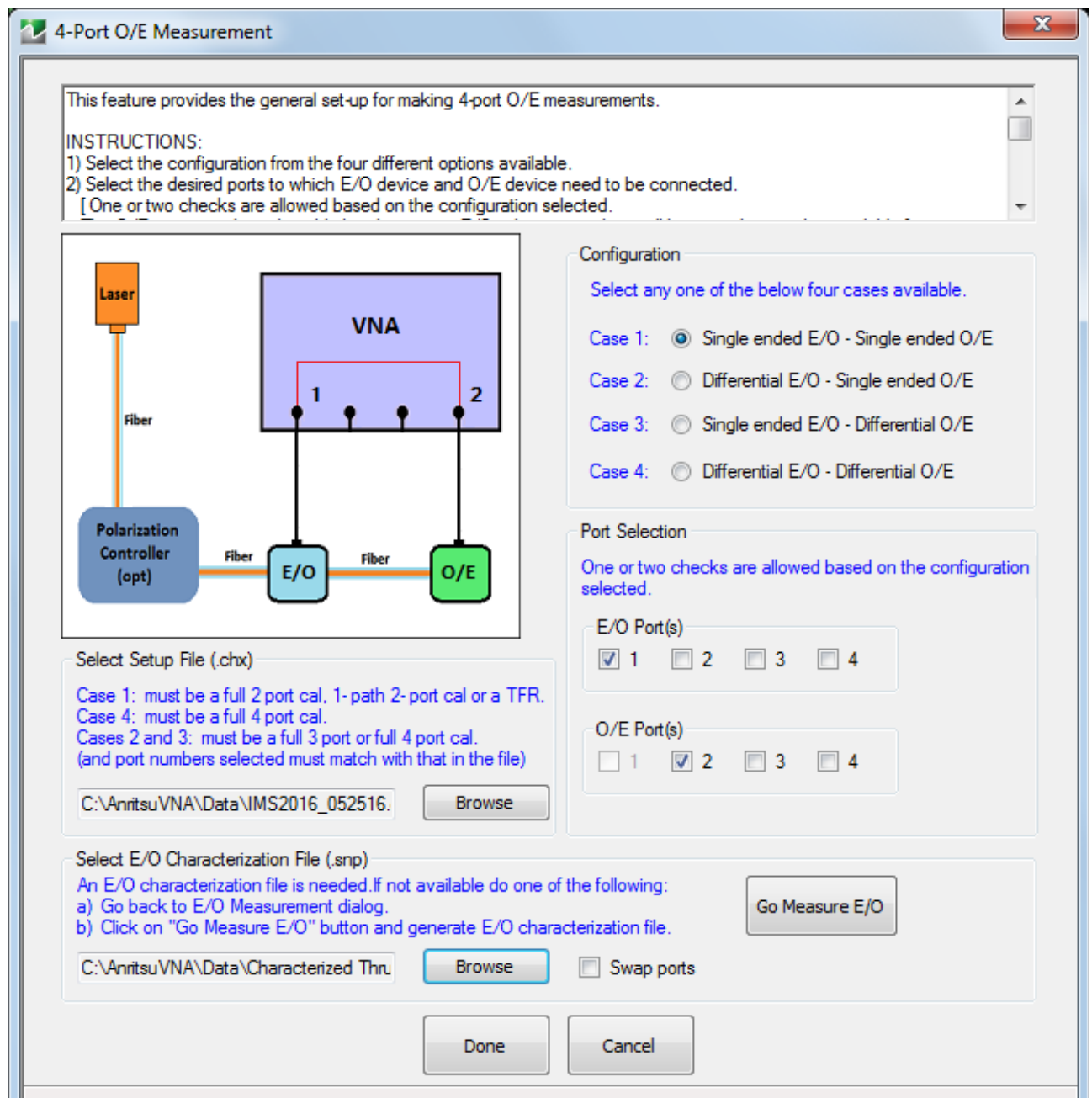


**Figure 18-12.** The dialog for 4-port E/O measurements is shown here.

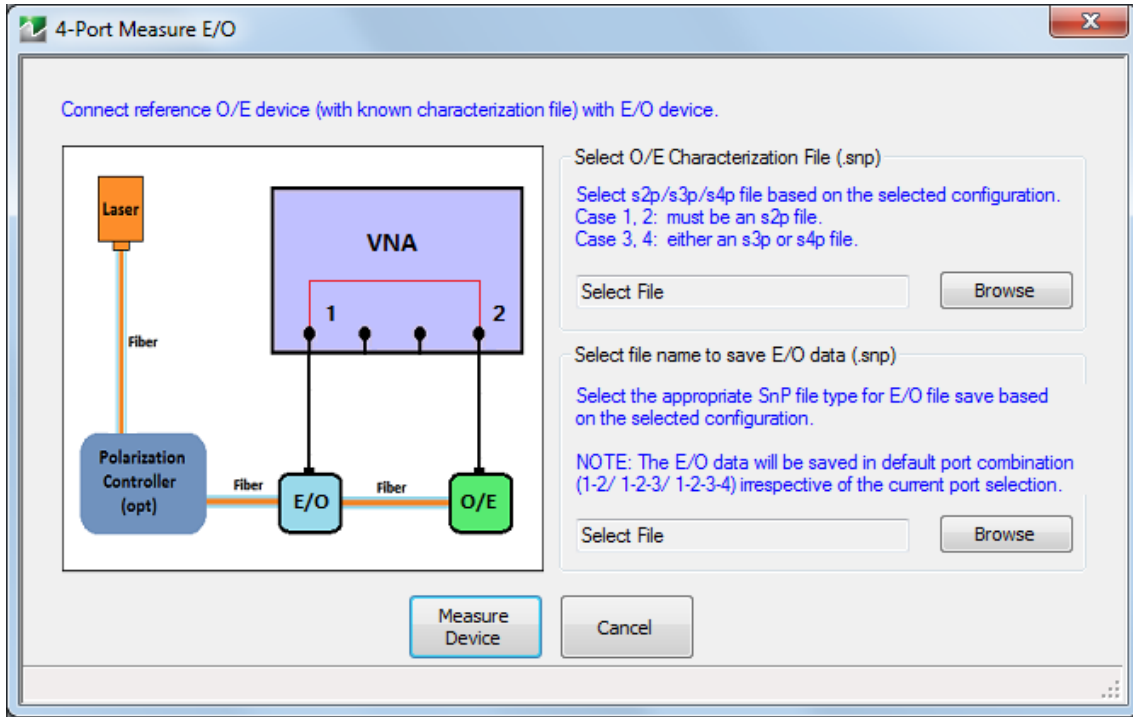


The O/E measurement setup is quite similar and that dialog is shown in [Figure 18-8](#). The difference, of course, is that an E/O characterization file must now exist. One can generate it using the previous procedure and saving the measurement result as an .s2p file or one may already have a characterization file for the E/O device. If this is not the case, a shortcut is provided to help generate an E/O characterization file with less work. This path is triggered with the Go Measure E/O button which will bring up the sub-dialog of [Figure 18-9](#).

Assuming one has an O/E calibration device (such as the MN4765X), this Go Measure feature allows one to load that photodetector characterization file and use the setup file found on the main E/O dialog to do a quick measurement of the modulator (or assembly). The sub-dialog also has a field to save this new E/O characterization file. When completed, one can go back to the previous dialog and select Done. The resultant setup will now have the Port 1 reference plane moved to after the modulator so one can now measure any number of new O/E devices. Again, the final setup (with shifted reference planes) can be saved as can any new measurement data of the O/E devices.



**Figure 18-13.** The dialog for 4-port O/E measurements is shown here.

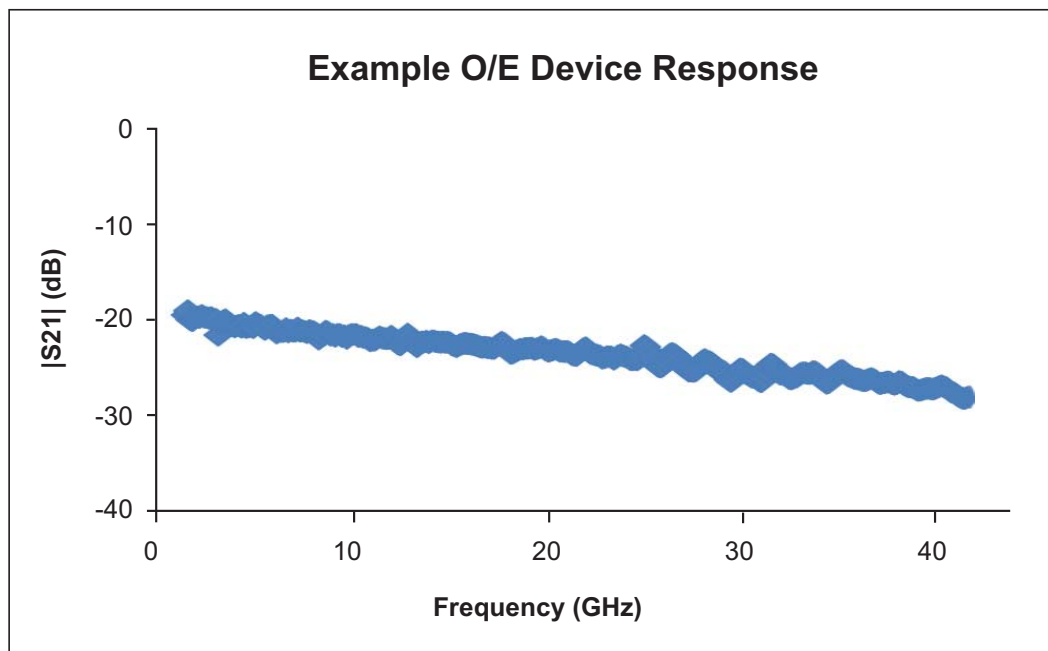


**Figure 18-14.** When measuring O/E devices, the characteristics of the E/O device must be known. If a file does not already exist, this dialog can help in doing the intermediate measurement with the help of a calibration O/E device such as the MN4765X.

**Example**

As an example, consider the following setup:

- 2 GHz to 40 GHz, 10 Hz IFBW, power  $-20$  dBm, no averaging.
- A full two-port SOLT calibration is performed using a 3652A Calibration Kit.
- The resulting setup file is saved as setup.chx. This setup file will include all of the above parameters including the calibration data.
- The optical assembly is hooked up with the modulator-under-test connected to Port 1 and an MN4765X O/E calibration module connected to Port 2 of the VNA. The laser is powered up after setting up bias control on the modulator and applying bias to the MN4765X (and, of course, connecting the fiber).
- The E/O measurement utility is invoked using the default port assignment, loading the .chx setup file and loading the characterization file of the MN4765X. Upon selecting Done on the dialog, the resulting S21 measurement reflects the conversion behavior of the modulator and is shown in Figure 18-10. In this case, there is about 10 dB of roll-off over the bandwidth of the measurement.



**Figure 18-15.** The results of an example 2-port E/O measurement are shown here using the procedure discussed in the text.

## 18-6 Uncertainties

In the measurements just described, the uncertainty can be broken into two broad categories:

1. Uncertainty associated with the characterization of the calibration device (such as the MN4765X)
2. Uncertainty in the measurement with the DUT

Typically the user will purchase a characterized photodiode and receive a data file describing that device's transfer function. There is some uncertainty associated with that data based on the characterization technique.

There are different levels of characterization possible. A direct characterization using such optical techniques as electro-optic sampling (e.g., [1]) or the heterodyne method (e.g., [2]) would be termed 1<sup>st</sup> tier. It is outside the scope of this note to go into detail on these characterization techniques but they are discussed in the references and elsewhere in the literature. These 1<sup>st</sup> tier characterizations are typically performed at National Metrology Institutes (NMIs, such as NIST or NPL) or large private laboratories.

A 2<sup>nd</sup> tier standard is characterized by a laboratory based on a 1<sup>st</sup> tier standard. It would be generated using a process similar to the techniques discussed here but under carefully controlled conditions (bias, temperature, wavelength, etc.) using a 1<sup>st</sup> tier standard as the characterization device. This 2<sup>nd</sup> tier device is much more commonly available (the MN4765X is an example) and the uncertainties for a 2<sup>nd</sup> tier standard will be used in later calculations. The uncertainty penalty in going to 2<sup>nd</sup> tier device is typically small (on the order of 0.1 dB additional).

When measuring the DUT, there is an uncertainty associated just with the VNA measurement which is discussed elsewhere (e.g., [5]). Since the characterized photodiode response is then de-embedded, the characterization uncertainty must be combined with the VNA measurement uncertainty to obtain an overall value. In the case of an O/E measurement, there are actually two user measurements involved (one with a modulator and the characterized photodiode and one with that modulator and the DUT) so an additional uncertainty must also be included (note the distinction between this second level de-embed and a 2<sup>nd</sup>-tier calibration device). Typically these uncertainties are all added on a root-sum-square basis since the measurements are assumed to be dominated by uncorrelated quantities.

Before proceeding to some uncertainty values, it may be useful to examine dependencies. On the VNA side, S21 uncertainty is typically quite low for medium power levels but will deviate at high signal levels (receiver compression, not an issue in these measurements) and at low signal levels (effects of the receiver noise floor). Thus the overall uncertainty will be a function of detector output signal level (getting worse as the signal level gets closer to the noise floor). Results can be improved by using higher RF drive levels (keeping all devices linear) and high optical power levels (same caveat). The RF match of the modulator and photodiode will also influence uncertainties to some degree (at all signal levels) but the dependence is relatively weak as long as return loss is better than a few dB.

On the optical side, there is little high level signal dependence as long as the devices are operating linearly. The characterized photodiodes are usually chosen to be very linear over wide power ranges to keep this from being an issue. The characterized detectors typically also have very weak wavelength dependencies; usually less than a few hundredths of a dB over 40 nm. When using a modulator as a transfer standard (as in an O/E measurement), however, it is important that the same wavelength be used in the different measurements with that modulator since much greater wavelength sensitivity usually exists in that component (although this will vary with technology). The use of different VNAs and/or calibration kits may result in slightly different values. Characterization uncertainties of the MN4765X O/E calibration device were used for the standard part of the model. Optical system drift is included in the error model but it is assumed that all components are mechanically and thermally stable. Connector repeatability is also included in the model but all connectors are assumed to be in very good condition. The results are shown with an independent variable of photodiode output power and plotted for both magnitude and phase for the two different types of measurements. Frequency is used as a parameter. While the results for a two port measurement are shown here, there are normally no significant deviations in going to four port structures.

## 18-7 Summary

The E/O and O/E measurement utilities have been discussed in this chapter. This utility is essentially an advanced de-embedding tool allowing one to remove the effects of one optical conversion device to learn the properties of the other. There are a large number of configuration choices, particularly in the four port cases, but the measurement principle is the same: use a good VNA calibration to characterize the converting pair and then de-embed the effects of a calibrated/characterized device to analyze the DUT. Signal-to-noise ratio is often a limiting uncertainty factor so it is important to carefully choose drive levels (as high as possible without being nonlinear), IF bandwidth, and averaging in order to optimize the measurements.

## 18-8 References

1. D. F. Williams, P. D. Hale, T. S. Clement, and J. M. Morgan, "Calibrating electro-optic sampling systems," 2001 Int. Micr. Symp. Dig., pp. 1527-1530, May 2001.
2. P. D. Hale and C. M. Wang, "Calibration Service For Evaluating and Expressing Optoelectronic Frequency Response at 1319 nm for combined photodiode/rf power sensor transfer standards," NIST Special Publ. 250-51, 1999.
3. D. Derickson, Fiber optic test and measurement, Prentice-Hall, pp. 252-263 and 621-638, 1998.
4. J. Hecht, Understanding fiber optics, Prentice-Hall, pp. 28-31, 1999.
5. "What is your measurement accuracy," Anritsu application note 11310-00270, 2001.
6. "E/O and O/E measurements with the 37300c series VNA," Anritsu Application Note 11410-00311, 2003.



# Chapter 19 — Multiple Source Control

## 19-1 Overview

Multiple source control is an application to independently control the internal source and receiver as well as up to four external synthesizers.

Since there are no constraints on frequency linkage (other than the ranges the hardware is capable of), a wide array of mixer, multiplier, converter and other specialized measurements can be performed. Some examples include:

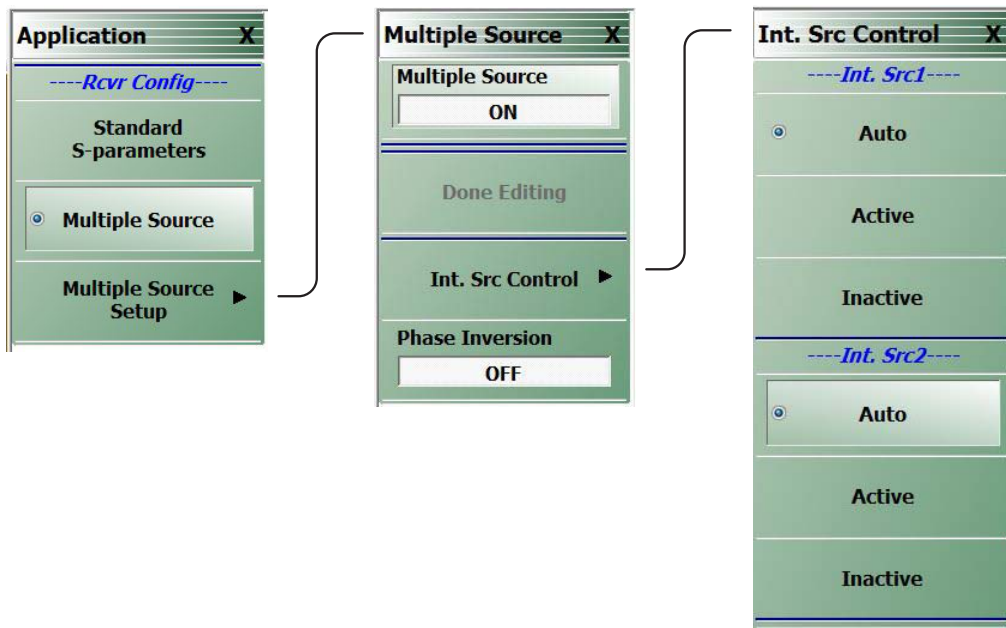
- Mixers
- Frequency multipliers
- Dividers
- Harmonic measurements (including the ability to look at fractional harmonics)

## 19-2 Introduction

This section discusses the interface and how to configure the instrument and the hardware for generic measurements. The MULTIPLE SOURCE menu selections are available from the primary APPLICATION menu as shown in [Figure 19-1](#) below

### Navigation

Main | Application | Multiple Source.



**Figure 19-1.** APPLICATION Menu – Multiple Source Selections

## 19-3 Multiple Source Control Set Up

The key concepts to setting up multiple source control are:

### Four Internal Sources for MS46524B VNAs

For MS46524B Series VNAs, up to four (4) internal sources can be configured.

### Two Internal Sources for MS46522B VNAs

For MS46522B Series VNAs, two (2) internal sources can be configured.

### Frequency Plan Bands

The frequency plan is separated into “bands”. There may be as many as 50 or as few as one. One needs multiple bands ONLY if the relationship between sources and the receiver change in an unusual way at some point in the sweep. Examples:

- A mixer measurement is being setup where the RF and LO are offset by a fixed amount and the IF (which will be sent to the VNA receiver) is constant. Only one band is needed.
- A harmonic converter is being tested where it operates on the 2nd harmonic of the LO up to 10 GHz and the 3rd harmonic beyond that. Two bands are needed here.

### Linearly Linked Source Frequencies

All source frequencies (internal or external) and the receiver frequency must be linearly related. All are expressed as linear equations as a function of a runner variable “f”. This variable f is always the one displayed on the X-Axis although it need not represent an actual frequency (although for convenience it usually does).

These linear relationships can change in different “bands” that the user defines. The band edges are always in terms of the runner variable f.

### Band Start Frequency, Band Stop Frequency, and Runner Variable f

The band start and stop frequencies are in terms of the runner variable f. Thus they may or may not be physical. To reiterate, the choice is usually based on what one wants the X-Axis of the plots to be labeled in terms of, for example, the RF frequency or the IF frequency for a mixer measurement.



### MULTIPLE SOURCE Menu

The main multiple source setup menu is shown below in [Figure 19-2](#). The top half of the menu, pertaining to equation editing, will be dealt with first. The special functions of the lower half of the menu will be discussed later.



The MULTIPLE SOURCE menu appearance differs slightly depending on the instrument model number, installed options, and band edit state.

Above:

- **Multiple Source** and **Phase Inversion** are set to OFF.
- Changing **Multiple Source** here also changes the selection on the **APPLICATION** menu.
- **Phase Inversion** set to OFF.

**Figure 19-2.** Main MULTIPLE SOURCE Setup Menu

The top button on the menu toggles Multiple Source mode on or off, similar to the mode selection buttons on the APPLICATION menu (turning Multiple Source mode off here will change the mode on the APPLICATION menu to Standard). When this menu is entered, the MULTIPLE SOURCE tableau will appear in the lower part of the screen ([Figure 19-3](#) below).

**Note**

The **Done Editing** button MUST be clicked for new values to take effect.

Band frequency ranges DO NOT define a required start and stop frequency. These merely set the min and max possible for start and stop. Readjust the desired range for actual measurements on the frequency menu.

When the MULTIPLE SOURCE tableau first appears, the first band is in the table. The Add Band, Delete Band, and Clear Band buttons will have the obvious effects.

Max Allowed Start Freq	Max Allowed Stop Freq	Src = (M/D) * (F + OS)	Src CW = (M/D) * OS	CW ON	Multiplier (M)	Divisor (D)	Offset Freq (OS)
50 kHz	8.5 GHz	Internal Source 1 (Auto)		<input type="checkbox"/>	1	1	0 Hz
		Internal Source 2 (Auto)		<input type="checkbox"/>	1	1	0 Hz
		Receiver (Auto)		<input type="checkbox"/>	1	1	0 Hz

The MULTIPLE SOURCE tableau dialog appearance differs slightly depending on the instrument model number and installed options.

**Figure 19-3.** MULTIPLE SOURCE Tableau

## Defining a Multiple Source Band

A red exclamation point (!) in the first column of the table indicates that an error is detected.

For each band, the following must be defined:

- A start frequency for the band.
- A stop frequency for the band.
- Equations for each source, the receiver, and receiver source (an index used to work with receiver calibrations). If a source is inactive, its equation may be left at anything. If active, the result of the equation must be a valid frequency for that source (or receiver).

Each equation is of the following form:

*If CW OFF is selected, then:*

$$Src\_X = \frac{M}{D} \cdot (f + OS)$$

*If CW ON is selected, then:*

$$Src\_X = \frac{M}{D} \cdot (OS)$$

### Equation 19-1.

Using the multiplier (M) and divisor (D), a rational relationship can be created between the desired frequencies. The offset (OS) completes the remainder of the linear relationship and is the CW frequency when the source is set to CW ON. Any of these parameters may be negative as long as the result of the equation is a valid frequency for that source (or receiver). This can be used for a reverse sweep (in certain mixer measurements for example).

When a cell is highlighted in the table (with the mouse or touch screen), the text entry box becomes active. Text can be directly entered into the table by double-clicking on the cell. The entry must be typed with a space between the number and the frequency units.

As soon as values are changed in the table, the Done Editing button shown in [Figure 19-2](#) becomes active. Selecting the Done Editing button will start an error check of all entered parameters. An error dialog may appear if an error is found. During the error checking, the system applies the band limit frequencies to each equation and checks that the results are valid for a given source or the receiver. If an external source is inactive, the error checking will not be performed for that line.

**Note**

The **Done Editing** button in the **Multiple Source** menu MUST be clicked for new values to take effect.

Band frequency ranges DO NOT define a required start and stop frequency. These merely set the min and max possible for start and stop. Readjust the desired range for actual measurements on the frequency menu.

# Chapter 20 — Maximum Efficiency Analysis (MEA)

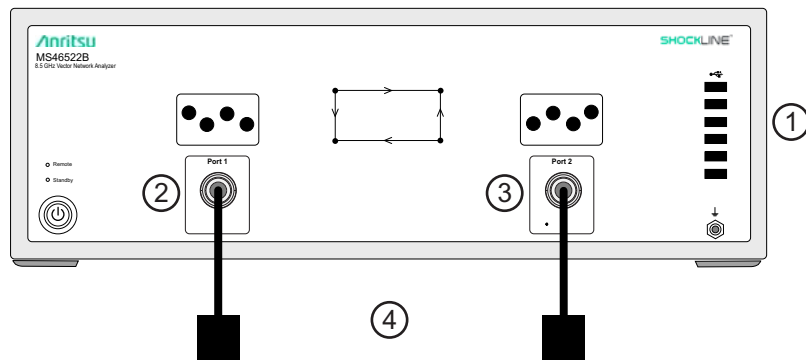
## 20-1 Chapter Overview

The ability to accurately measure maximum efficiency and the  $kQ$  product for Wireless Power Transfer (WPT) systems is becoming very important. Anritsu, in collaboration with Toyohashi University of Technology have provided a measurement system that evaluates the product of the WPT coupling coefficient and quality factor. This  $kQ$  product is mathematically related to the maximum efficiency of the WPT and both can be shown in real time.

More and more devices are becoming disconnected from cables as wireless power transfer continues to become a dominant technology. This chapter will discuss some of the measurements of interest, setup considerations, and examples of execution procedures.

## 20-2 Introduction and Background

The VNA acts as a wireless power transfer system that transfers electromagnetic power from one VNA port to the other VNA port via TX/RX elements.

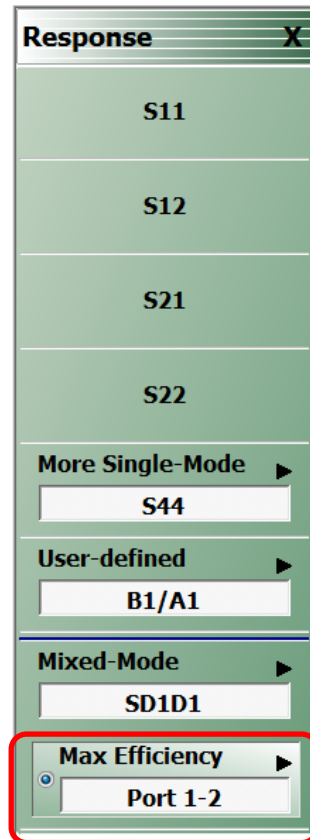


Index	Description
1	ShockLine MS4652xB VNA
2	VNA Port 1
3	VNA Port 2
4	Transmit/Receive (TX/RX) Elements

**Figure 20-1.** A general 2-Port MEA measurement setup is shown here. The Transmit/Receiver elements are not limited to coils or antennas and can be a device that moves electromagnetic energy.

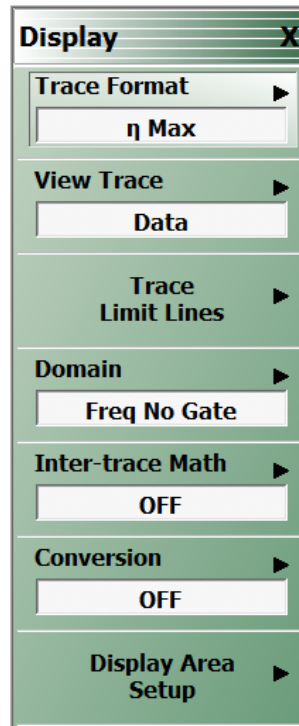
## Software Setup for Maximum Efficiency Analysis

ShockLine software provides a simple interface to setup parameters for Maximum Efficiency Analysis. The initial parameter that must be setup is the Response type. The Response type is not an S parameter but a Z parameter that is mathematically manipulated to provide key parameters for measuring a WPT system. The correct response for this measurement Max Efficiency as shown in [Figure 20-2](#) below.



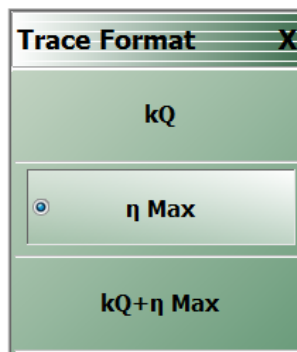
**Figure 20-2.** Response Menu with Max Efficiency for WPT

When the Response type has been set to Max Efficiency, ShockLine software enables a set of hidden menus that allows the user to access kQ product and maximum efficiency buttons. This menu is accessible via the ShockLine customized toolbar or through the Main menu function.



**Figure 20-3.** Display Menu with enabled Maximum Efficiency Analysis display options

The Display type will be limited to  $\eta$  Max (Maximum Efficiency), kQ or both. The user may want to see one format, the other or both and the measurement data is real time.



**Figure 20-4.** Trace format options for MEA