



# Coherent Optical Signal Generation with High-Performance AWG

## Table of Contents

<b>Introduction to Coherent Optical Communications</b>	<b>.. 3</b>
Traditional Optical Links	..3
Increasing Spectral Efficiency through Coherent Optics and Complex Modulation	..5
<b>High-Speed Arbitrary Waveform Generators</b>	<b>..... 8</b>
Arbitrary Waveform Generator Architectures and Characteristics	..8
High-Performance AWGs and the Interleaving-DAC Architecture	..9
Multiple Channel AWGs and Synchronization Requirements	..11
<b>Generation of Coherent Optical Signals using AWGs</b>	<b>.....13</b>
Complex Modulation Methods	..13
Optical Modulators	..15
Baseband Signal Generation	..16
OOFDM Signal Generation	..19
<b>AWG Desirable Performance and Characteristics for Coherent Optical Signal Generation</b>	<b>.....19</b>
Bandwidth and Sample Rate Requirements	..19
Vertical Resolution Needs	..20
Waveform Memory Size	..20
<b>Linear and Non-linear Distortion Addition and Compensation</b>	<b>.....22</b>
Ideal, Distorted, and Corrected Waveforms	..22
Non-linear Distortions	..24
<b>Signal Generation for Polarization Division Multiplexing (PDM)</b>	<b>.....26</b>
PDM Requirements	..26
State-Of-Polarization (SOP) Emulation	..27
Channel Count Reduction	..28
<b>Conclusions</b>	<b>.....29</b>

The Tektronix AWG70000 Series Arbitrary Waveform Generator (AWG) can reach sampling rates as high as 50GSa/s with 10 bits vertical resolution. Such level of performance allows for the direct generation of IQ basebands signals required by modern coherent optical communication systems based on quadrature modulation of an optical carrier with data rates well over 200Gb/s. The purpose of this paper is to show how instrument characteristics and performance level of the AWG70000 influence the ability to generate different modulation schemes and the way the instrument's flexibility can be used to compensate for internal and external device imperfections and to emulate component and link distortions.

## Introduction to Coherent Optical Communications

### Traditional Optical Links

The ever-increasing need for capacity in metro and long-haul networks has resulted in the continuous improvement of the optical network infrastructure all around the World. Over the years, capacity has been improved through the combination of multiple mechanisms:

- Installation of additional fiber optics cables
- Increase of the baud rate for a given link
- Improvement of the transmission characteristics of the fiber by reducing or mitigating the effects of attenuation and dispersion
- Multiplex of multiple signals in a single fiber by assigning different wavelengths to them
- Increase of the number of wavelengths transported by a single fiber by reducing the distance between them
- Addition of FEC (Forward Error Correction) techniques to enable faster connections in in lossy or dispersive environments.

The above improvements have been applied over time to optical signals using the traditional OOK (On-Off Keying) direct modulation scheme. Information is coded by controlling two states of the optical transmitter. Ideally, in one of them full power is transmitted while in the other zero power should be transmitted so only one bit can be coded by each symbol.

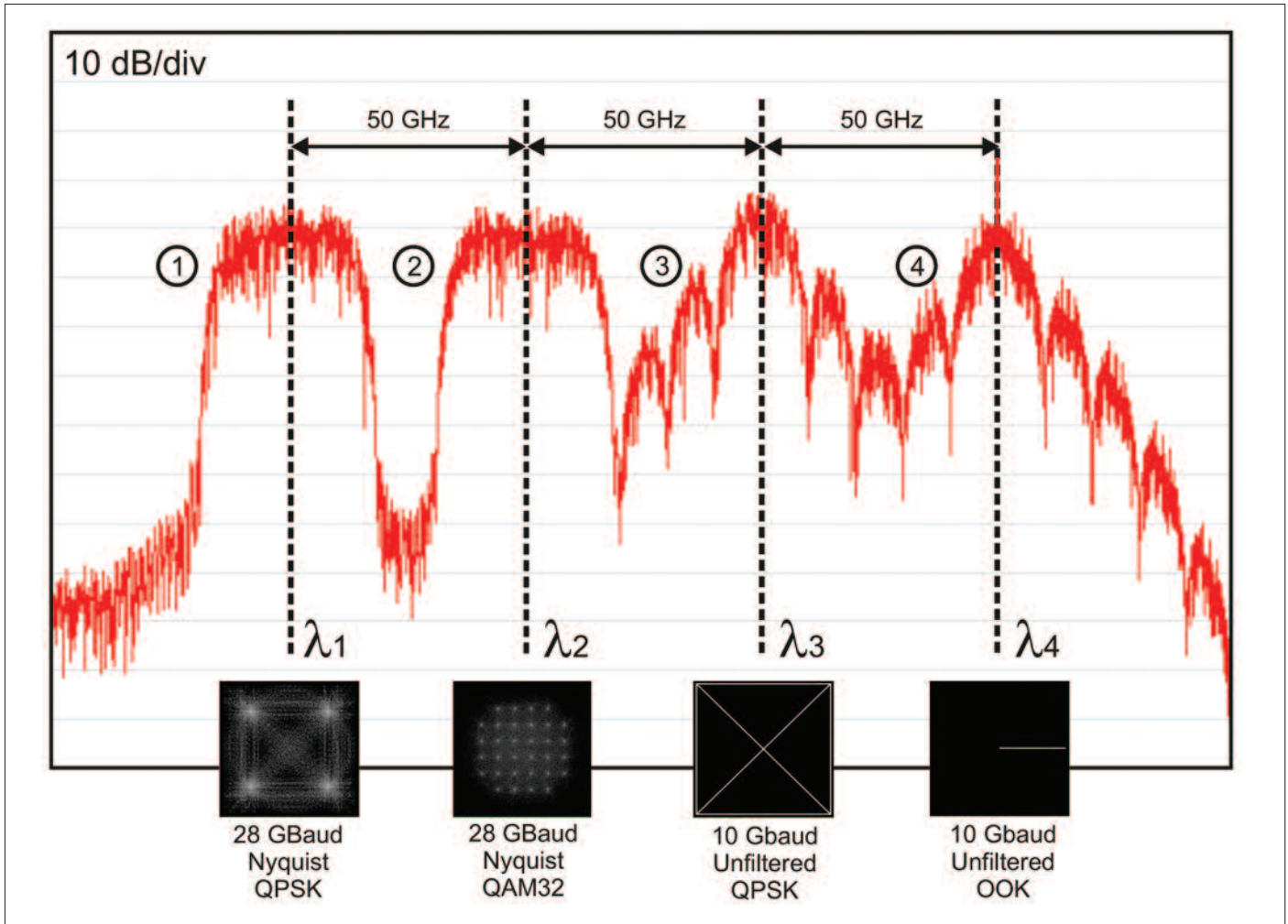
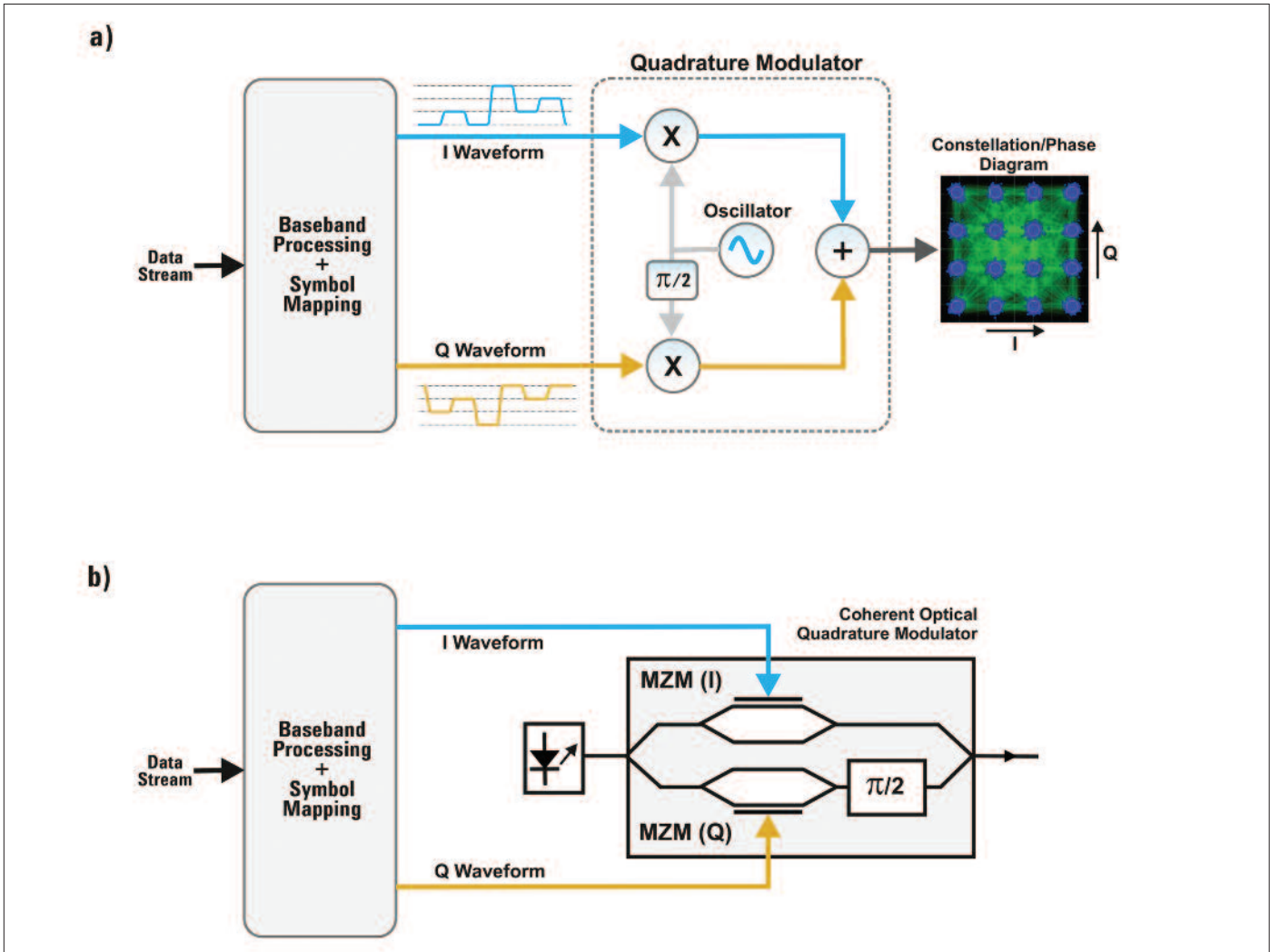

**Figure 1.** Spectral efficiency of optical transmissions may be improved by modulating both the amplitude and the phase of an optical carrier, which requires coherent modulation and detection. In this WDM link, four different wavelengths share the same fiber in a standard ITU 50GHz grid. Wavelength 4 is carrying a 10Gb/s signal using the traditional intensity modulation (or On-Off Keying, OOK). Part of the optical power goes directly to the carrier and does not transport any information. Carrier 3 is modulated using a QPSK modulation so 2 bits are transported by each symbol, doubling the capacity of the OOK-modulated channel in the same bandwidth. Capacity may be increased through the usage of more complex modulations or baseband filtering. Wavelengths 1 and 2 transport 28 Gbaud signals with 2 and 5 bits per symbol respectively.

As bits are transmitted faster and faster, optical signals drift away from the ideal conditions and issues like bandwidth (both optical and electronic) and dispersion (especially Chromatic Dispersion) start to raise a wall impeding further improvements. Ultimately, the distance between contiguous wavelengths in a DWDM (Dense Wavelength Division Multiplexing) installation also limits the maximum baud rate an individual wavelength can be modulated (Figure 1). Otherwise, beyond some limit, each wavelength would interfere with the adjacent wavelengths compromising the bit error rate level. Under these conditions, information is carried by a single optical parameter: power. Phase of the optical carrier is not typically important until its behavior affects the capability to

support transmissions at the required speeds. Line width, a form of phase-noise, or chirp (which changes in the wavelength during fast transitions) increase the bandwidth of each optical signal so the effects of wavelength-to-wavelength interference and dispersion grow.

Presently, traditional OOK-based DWDM links carry up to 160 10Gbps channels (1.6 Tbps aggregated capacity) in a 25GHz ITU grid or up to forty 40Gbps channels in a 100GHz ITU grid. Commercial success of 40Gbps OOK modulated channels has been rather limited as it is only feasible at the expense of much higher cost and complexity due to the electronics involved and the need to apply powerful dispersion compensation techniques.<sup>5</sup>

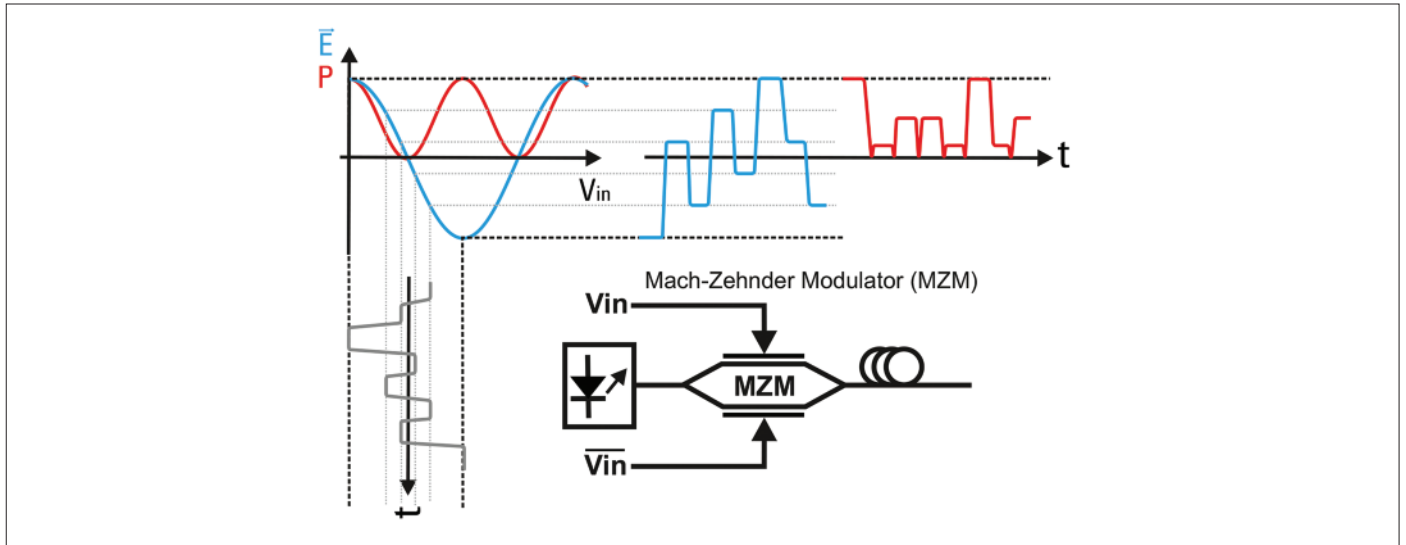

**Figure 2.** One way to modulate the amplitude and the phase of a carrier is a quadrature modulator. There, two baseband signals, called I (or In-phase) or Q (Quadrature), modulate in amplitude two orthogonal carriers (90° relative phase) so any state of modulation can be accomplished. The same scheme may be implemented for optical carriers by using two Mach-Zehnder Modulators (MZM) in an arrangement known as “Super-MZM” cell.

## Increasing Spectral Efficiency through Coherent Optics and Complex Modulation

Wireless and cable RF transmission systems faced similar problems in the past. Improvements in the capacity have only been possible through advances in modulation and coding techniques. Common trends have been the usage of higher order modulation schemes, where more than one bit is transmitted during a symbol period, and the exploitation of different kinds of orthogonality, where multiple independent messages can be sent simultaneously over the same link. The key for the success of both strategies is the ability to control the

amplitude and phase of the RF carrier. The simplest way to send two independent transmissions over the same carrier frequency is to use orthogonal carriers with 90 degrees phase difference. In real-world implementations, both messages are typically synchronous. The two messages can be independently decoded at the receiver if the original orthogonal carriers are recovered and coherent detection is applied. Using combined amplitude and phase control, it is feasible to map an alphabet of M symbols (typically  $M=2^n$ ) to M states of modulation or amplitude/phase combinations. A quadrature modulator (Figure 2a) is a typical implementation

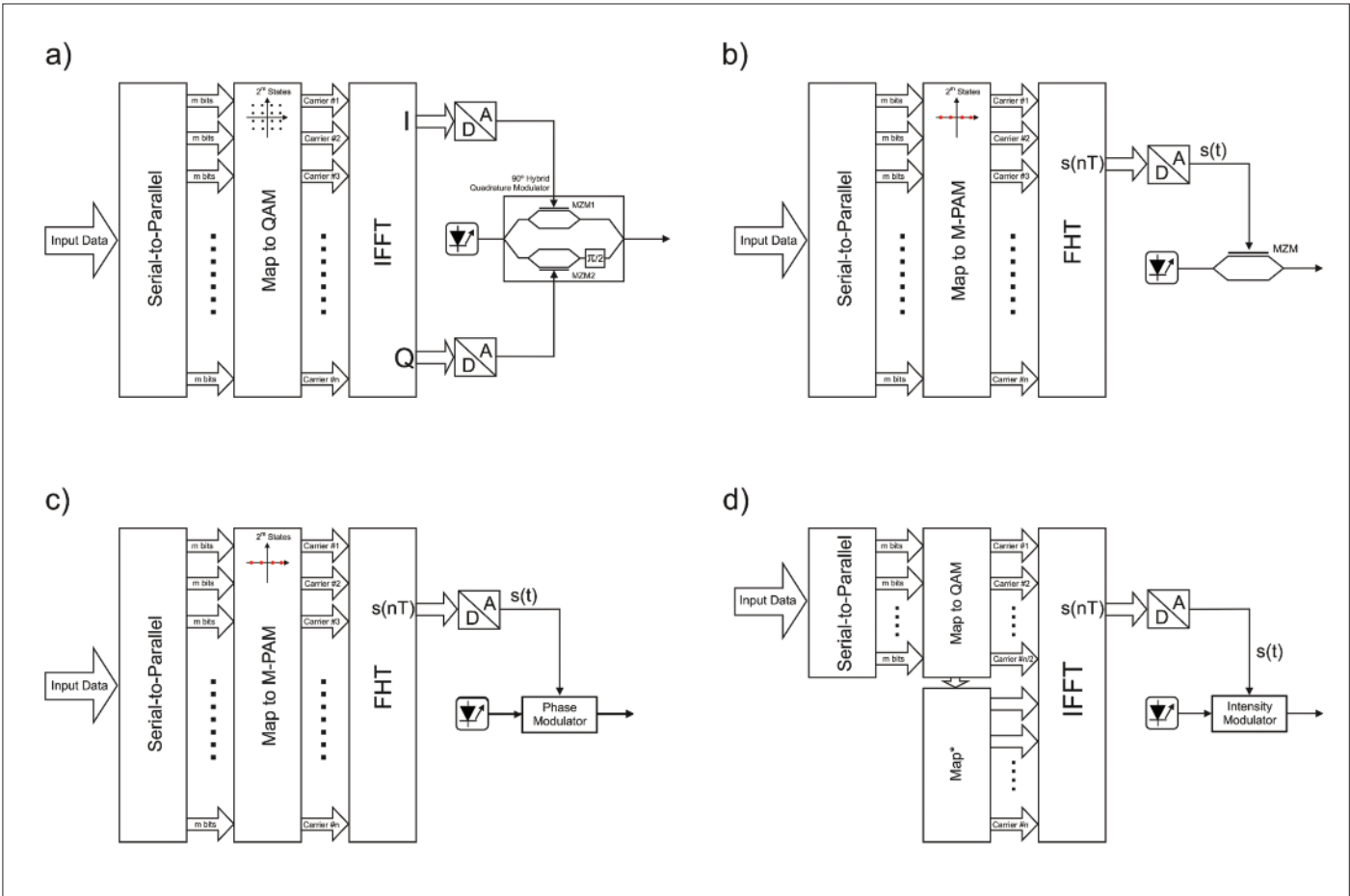

**Figure 3.** Mach-Zehnder Modulators are non-linear devices and require relatively high amplitude voltage swings to work. They may be driven by single-ended or differential electrical signals. Linearity is an important requirement for proper multi-level modulation. Here a 4-level electrical signal (one of the baseband components of a QAM16 signal) is distorted so electrical field at the output of the modulator remains linear.

for an actual transmitter. There, phase and amplitude of the carrier are controlled by setting independently bipolar amplitude levels over two carriers with  $90^\circ$  phase difference forming a Cartesian (thus orthogonal) axis arrangement: the I (or In-phase) and Q (or Quadrature) components. The location of symbols in the IQ plane is known as the Constellation Diagram. Popular modulation schemes such as QPSK (2 bits/symbol Quadrature Phase Shift Keying) or M-QAM ( $\log_2 M$  bits/symbol Quadrature Amplitude Modulation) show symmetrical, square constellation diagrams although there are other configurations or constellation shapes. An important issue of coherent transmission systems is that good spectral purity is required as phase noise translates directly to symbol location inaccuracies and, as a consequence, errored bits.

On paper, the same approach to capacity improvements would be desirable to increase the spectral efficiency (the amount of bit/s that can be fitted in 1Hz bandwidth) of optical transmission systems. As this method requires controlling both the power and the phase of an optical carrier, such communication systems can be defined as coherent optical links. A typical implementation of a coherent optical transmitter requires the usage of two Mach-Zehnder Modulators (MZM) modulating two orthogonal optical carriers with independent I/Q bi-level (BPSK or QPSK) or multi-level (M-QAM) baseband electrical signals (Figure 2b). Mach-Zehnder interferometers are non-linear devices so proper symbol location is only possible by applying properly distorted multi-level electrical signals (Figure 3).





**Figure 4.** OFDM (Orthogonal Frequency Division Multiplex) signals are extremely popular in the wireless world. Their resilience to linear distortions introduced by the network such as Chromatic Dispersion (CD), or Polarization Mode Dispersion (PMD), and their inherent limited bandwidth make them very attractive for optical transmission as well. OOFDM (Optical-OFDM) is based in different modes other than the traditional Complex-FFT approach so popular in wireless and broadcast networks (a). Some less efficient schemes are being experimented in exchange for simplicity or cost. Some are based in the Fast Hartley Transform (FHT) (b, c) which result in a real-only signal so quadrature modulator is not necessary. In some cases, it is even possible to avoid the usage of coherent optics by using direct modulation (d). Peak-to-average-power ratio0 is an important drawback of OFDM signals. In c) the same real-only OFDM signal is modulating the phase of an optical carrier, not the amplitude, so optical power does not change over time.

Orthogonality principles can also be applied in the frequency domain. OFDM (Orthogonal Frequency Domain Multiplex, Figure 4) requires the independent synchronous modulation of multiple carriers to be spaced exactly  $1/\text{Baud Rate}$  HZ apart.<sup>4</sup> In this way, it is possible to recover the modulation state for each individual carrier without experiencing any inter-carrier interference. OFDM modulation can also be implemented through the application of IQ baseband signals to a quadrature modulator. These baseband signals are obtained by mapping the modulation states to the individual carriers in the frequency domain and by applying a complex IFFT to them.

OFDM signals are very resilient to dispersion as bandwidth for each individual carrier is relatively narrow (and symbol duration correspondingly long). On the other hand, the need of complex signal processing and the high peak-to-average ratio (PAPR or Crest Factor) pose potential challenges. OOFDM (Optical-OFDM) techniques, some of them specially developed for their application to optical transmission systems, are a subject of intensive research and trials given the potential advantages over more traditional, single-carrier modulation schemes.

Another area where orthogonality can be found is light polarization. This technique makes it possible to transmit two independent messages over two optical carriers with orthogonal states of polarization (i.e. 90 degrees apart linear polarizations or clockwise and counter-clockwise circular polarization). This strategy is known as Polarization Division Multiplexing (PDM or PM). Regular optical fibers do not maintain the original SOP (State Of Polarization) over distance and over time so being able to estimate and track it in real-time at the receiver side is an important feature of optical receivers.

Researchers and engineers require adequate tools to validate, diagnose, and produce their designs, prototypes, and products. The goal of Test & Measurement (T&M) manufacturers is to provide the appropriate tools. Stimuli devices, capable of generating optical and electrical signals with enough quality, repeatability, and accuracy, are necessary to test receivers and other components, systems and sub-systems, even entire networks. These signal generators must be able to generate perfect (“golden”) or impaired signals and they must be capable of emulating the effects of interconnections and transmission systems. This paper will show how an ultra-high-performance Arbitrary Waveform Generators (AWG) can be applied to the field of coherent optical signal generation and how to evaluate AWG capabilities and level of performance.

## High-Speed Arbitrary Waveform Generators

### Arbitrary Waveform Generator Architectures and Characteristics

The goal of any arbitrary waveform generator<sup>7</sup> is to supply signals that are not limited in their shape, characteristics, and application beyond the operating limits established by their basic specifications. The basic block diagram looks like that of a real-time digital storage oscilloscope (DSO) with an

important difference: the flow of the signal goes in the opposite direction, from the waveform memory to the data converter (a Digital-to-Analog Converter or DAC). The main specs for AWGs are the following:

- **Sample Rate (SR):** The maximum speed at what digital samples can be converted to analog samples by the DAC. Some AWGs use interpolating architectures where the DAC’ sampling rate is higher than the sample transfer speed from the waveform memory.
- **Analog Bandwidth (BW):** The effective bandwidth for useful signals being generated by the generator. Analog bandwidth may be lower, equal to, or higher than the Nyquist bandwidth (SR/2) established by the sampling theorem.
- **Record Length (RL):** Size of the waveform memory. It influences the longest non-repeating time window that can be generated at a given sampling rate.
- **Vertical Resolution (Res.):** The number of bits that define a sample in the DAC. This specification influences dynamic range as quantization noise depends on it.
- **Number of Channels:** The number of arbitrary waveforms that can be generated simultaneously (usually synchronously) with the same AWG device. Channel count can be increased in some instruments by synchronizing multiple units. Synchronization quality is a very important issue in this kind of arrangements.

Beyond the basic specifications, AWGs can differ in their architecture. Ultra-high-speed AWGs (SR  $\geq$  25GSa/s) implement the architecture known as “true-arb” (Figure 5a). This architecture is characterized by the way samples from the waveform memory are read: sequentially. As a consequence, changing the timing of the output signal requires either changing the waveform in the memory and/or changing the sampling rate.



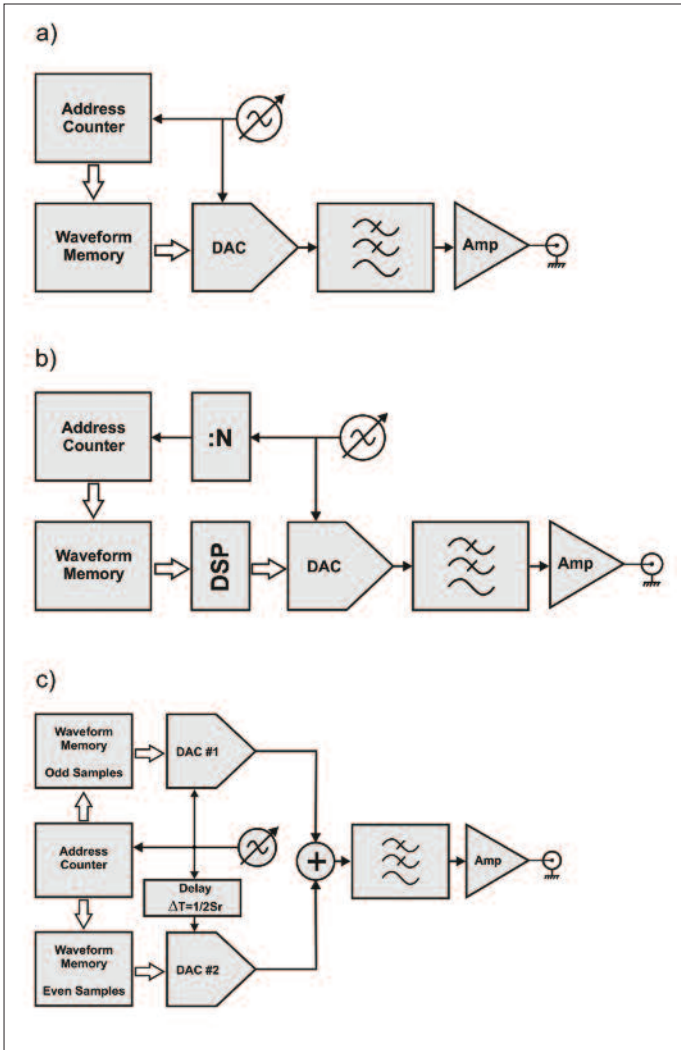

**Figure 5a, b, c.** Arbitrary Waveform Generator block diagram look close to that of a digital storage oscilloscope, or DSO (a). “True-arb” architectures (a) transfer samples from a waveform memory to the DAC at its conversion speed. Interpolating-DAC AWGs (b), transfer samples from the memory at a fraction of the DAC’s sampling rate so intermediate samples must be interpolated. Although this architecture has some advantages, actual signal bandwidth is primarily limited by the memory transfer speed. DAC-interleaving AWGs, such as the Tektronix AWG7000 and AWG70000 series, can combine two AWG channel to effectively double the sample rate of the instrument so sampling rates as high as 50GSa/s may be reached.

## High-Performance AWGs and the Interleaving-DAC Architecture

There are also some variants of the basic “true-arb” architecture. One such variant reduces the transfer rate from waveform memory to the converter block by using internal interpolation. Interpolated-DAC (Figure 5b) improves performance as the increased sampling rate results in unwanted images located farther away (and easier to remove through filtering) and a better DAC frequency response. Although it does not improve the Nyquist frequency as this is effectively conditioned by the original sampling rate of the signal stored in the waveform memory.

Interleaved-DAC architecture (Figure 5c) goes in the opposite direction as it is designed to obtain higher effective sampling rates by interleaving multiple DACs,<sup>8</sup> typically two of them (Figure 6). It can be seen as two “true-arb” channels properly timed so odd and even samples are stored in each channel’s memory. Ideally signals coming out from each channel should be switched on and off alternatively. Implementing switches which are fast enough to support the required low signal distortion and noise is extremely difficult, requiring actual implementations to add the output from both channels with channel-to-channel delay of half the sampling period ( $1/2SR$ ). This arrangement effectively doubles the Nyquist frequency to  $2 \times SR$  although the first null of the DAC zeroth order hold response stays at the same value. Tektronix is using this approach in high-speed AWGs with some important improvements:

- Transparent HW/SW interconnection of both AWG channels.
- Improved frequency response and image rejection through equalization and factory alignment.

On paper, AWGs can generate signals with bandwidths up to half the maximum sampling rate ( $SR/2 = \text{Nyquist Frequency}$ ). However, bandwidth is also limited by the ideal DAC zeroth-order hold response (or  $\text{Sin}(f)/f$ ) and the analog response of the output circuits such as amplifiers and reconstruction

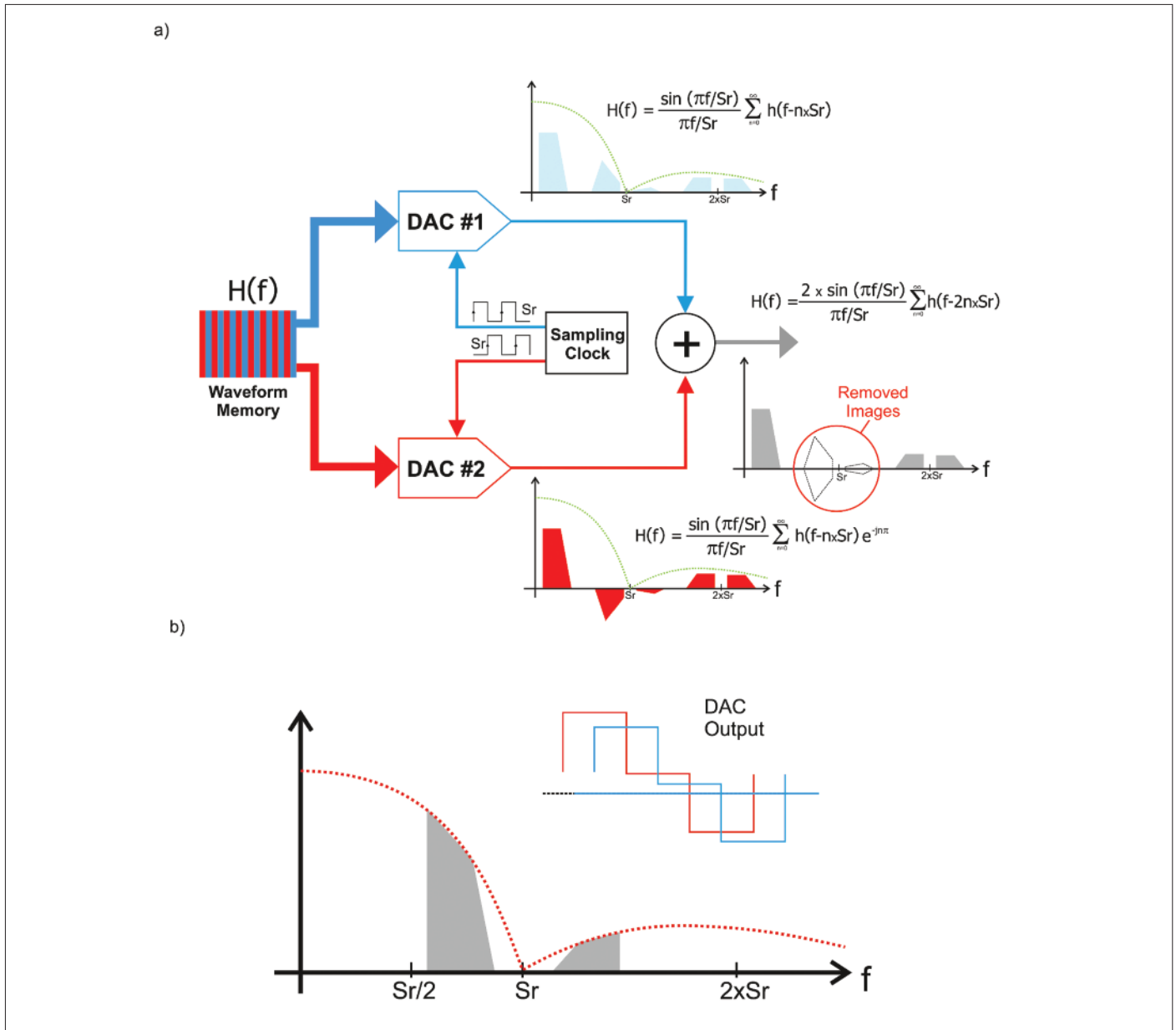

**Figure 6.** Interleaving-DAC AWGs can double the effective sampling rate as the two channels convert alternative samples delayed by half the sampling period (a). In this way, images located in the second Nyquist band (from  $Sr/2$  to  $Sr$ ) are nulled and any signal from DC up to  $Sr$  may be implemented.

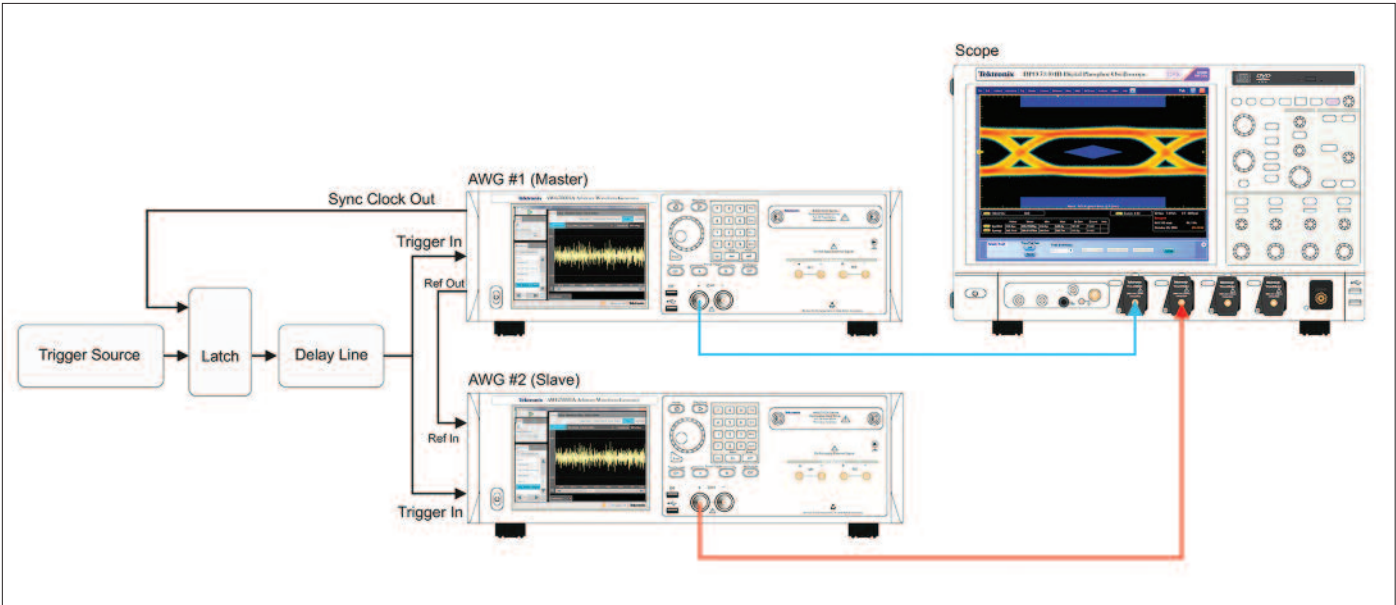
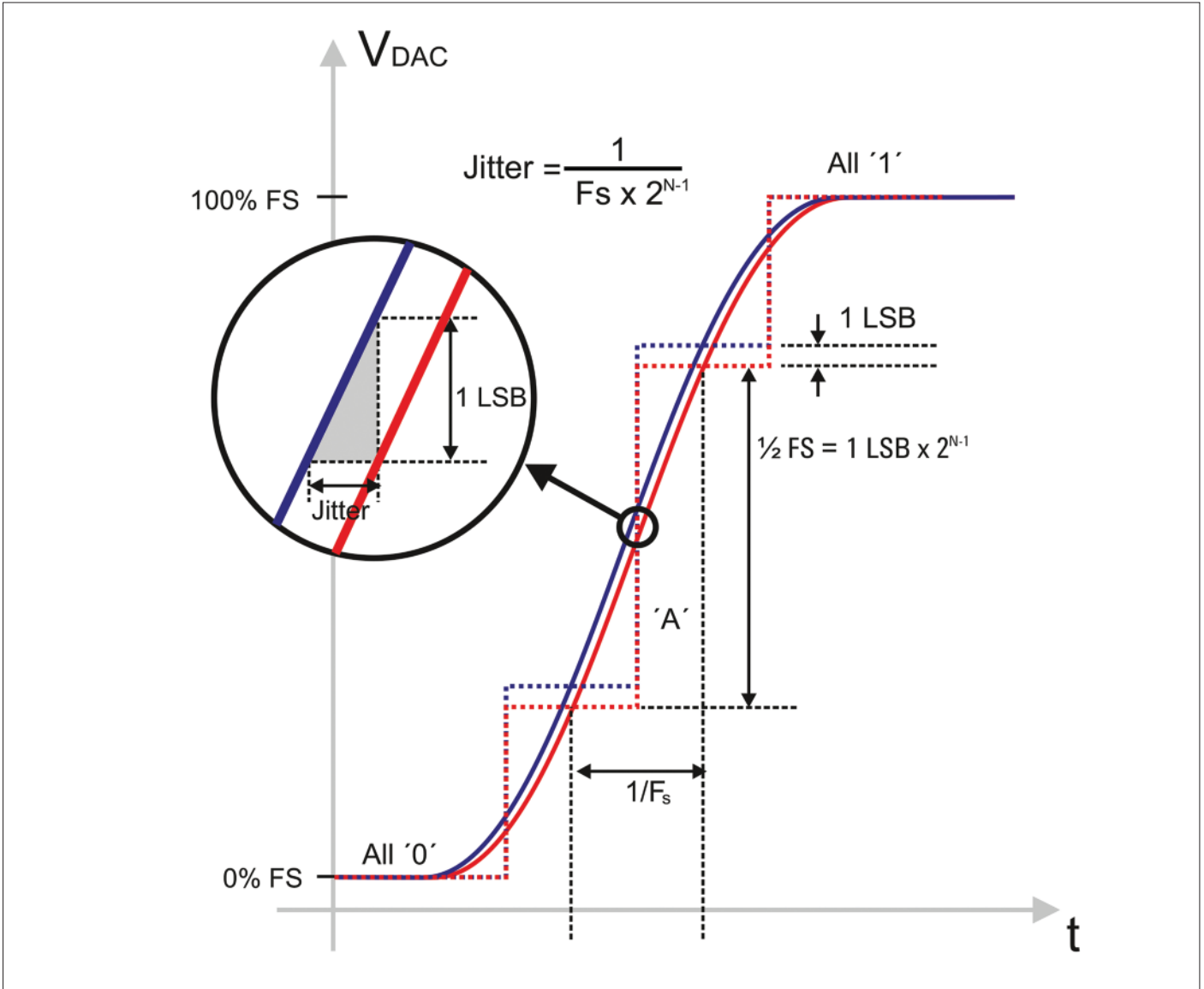

**Figure 7.** Complex modulation requires multiple synchronous baseband signals (up to 4 in a Polarization Division Multiplex link). Synchronizing multiple AWGs is extremely important to obtain useful signals. Here, the recommended multi-instrument synchronization scheme for the Tektronix AWG70000 series is shown. With this arrangement, channel-to-channel skews better than 4ps can be obtained.

filters. The need to eliminate the unwanted images created by the conversion process also limits usable bandwidth due to the reconstruction filter unavoidable roll-off. All these factors can reduce effective bandwidth to up to  $SR/2.5$ . Frequency coverage may be improved using equalization techniques in the analog or digital domains. In the analog domain, the usage of pre-emphasis filters can boost and flatten the high frequency response at the expense of increasing the noise at those frequencies. In the digital domain, DSP techniques can be used to pre-correct the waveform samples to obtain the same results at the expense of reducing the signal amplitude and, as a consequence, doing the same with the available dynamic range and the signal-to-noise ratio.

## Multiple Channel AWGs and Synchronization Requirements

Some applications, such as IQ baseband signal generation, require more than one channel.<sup>10, 12</sup> All the channels involved must be synchronized, so they must share the same sampling clock, and be time-aligned. Any timing difference or channel-to-channel jitter will result in a reduced quality signal. Ultra-high-speed AWGs use to incorporate one or two channels. Internal synchronization and alignment of two channels is simpler and more repeatable than synchronizing two or more channels from multiple instruments. Standardized synchronization methodologies and appropriate firmware can greatly simplify the alignment tasks and dramatically improve repeatability and reliability (Figure. 7).



**Figure 8.** The edge positioning capability of any AWG depends on two main factors: sampling rate and vertical resolution. Edge positioning granularity translates into increased intrinsic jitter. In a 6-bit vertical resolution AWG, this component of jitter will be 16 times larger than that of a 10-bit vertical resolution AWG, such as the Tektronix 70000 series.

As sampling rates in AWG and symbol speeds to be emulated by them grow, intrinsic jitter becomes an increasingly important performance consideration. Unwanted jitter can be generated by AWGs due to things such as sampling clock instability, timing uncertainties in the DAC, and analog. In IQ signal generation, jitter may show up as phase noise and degraded dynamic range. Still, even under perfect timing conditions, vertical resolution and sampling rate, a minimum intrinsic jitter is present in any AWG (Figure 8).

For instruments with 10 bits of vertical resolution, such as the Tektronix AWG70000 series, this unavoidable intrinsic jitter is negligible with respect to other sources of jitter but this is not the case for 6 bit instruments. The same consideration applies to jitter emulation when intrinsic jitter becomes jitter noise floor and vertical resolution determines edge-positioning resolution as well.

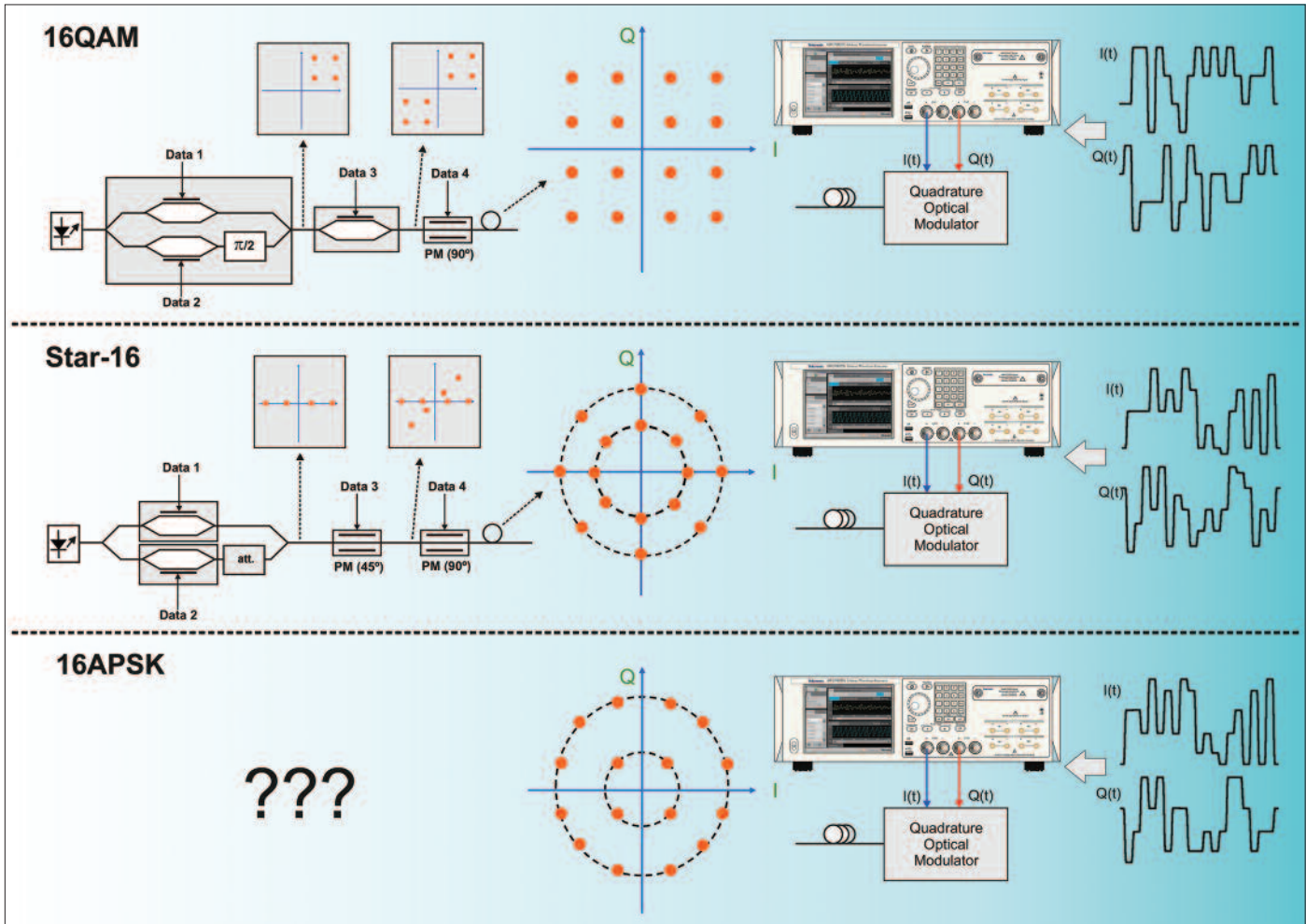

**Figure 9.** Some complex modulations can be generated by directly applying two-level signals (i.e from a high-speed pattern generator) to optical modulation components. For some modulation schemes, though, this is difficult or even impossible. Here, a square-constellation QAM16 and a STAR16 modulation schemes are implementing using this approach. However, a 16APSK constellation cannot be implemented in this way. Notice the difference in the modulators components and their connection. All these modulation schemes can be generated through the combination of a two-channel AWG and an optical quadrature modulator. Additionally, AWGs can be set-up to generate distorted signals without any change in the hardware.

## Generation of Coherent Optical Signals using AWGs

### Complex Modulation Methods

Quadrature modulation is one of the possible methods to obtain optical signals modulated in amplitude and phase.<sup>10</sup> Many modulation schemes may be implemented under direct digital control (i.e. digital signals from a high-speed pattern generator) through the smart combination of different amplitude and phase modulators (Figure 9). Although these implementations may be successfully used in real-world links,

they are not suitable for test applications for several reasons:

- Implementation varies dramatically from one modulation scheme to another so it is impossible to implement multiple modulation schemes with the same generation system.
- Applying linear or non-linear distortions to the signal is virtually impossible so generating near-perfect or distorted signals with the same device is not feasible.
- Only single-carrier modulation schemes may be implemented. OFDM signal cannot be generated using this scheme.



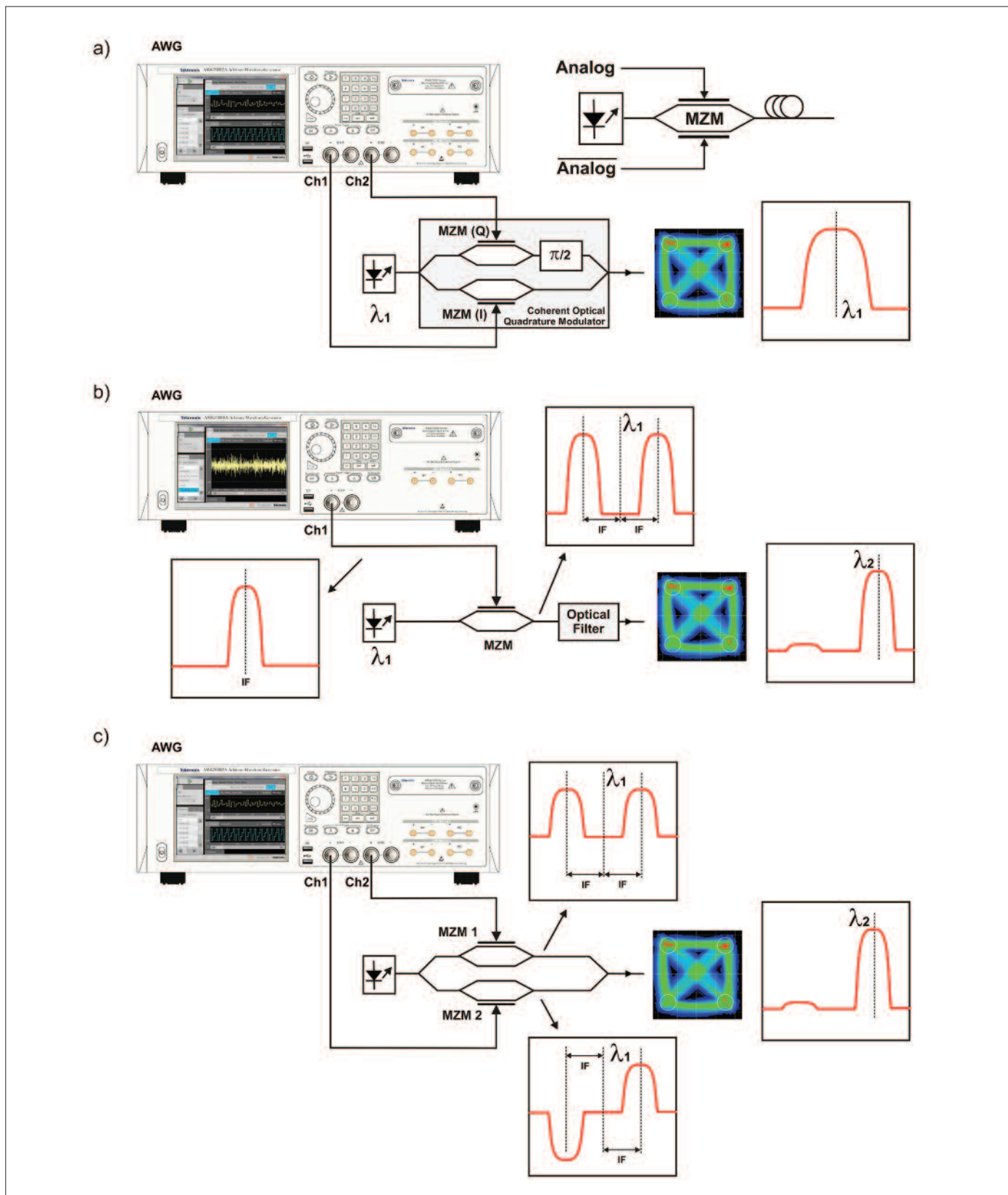

**Figure 10.** There are several ways to obtain complex modulated signals in the optical domain other than a two-channel arb and a quadrature modulator (a). Fast enough one-channel AWGs can generate a IF signal that can be up-converted through an amplitude modulator (b). The output will consist of two modulated carriers so one of them must be removed through filtering. A two-channel generator can generate two almost identical IF signals with the exception of the phase for each carrier and applied to two balanced amplitude modulators to get rid of one of the images. Notice that the phase of the optical carrier is the same for both modulators.



The combination of two-channel (or two synchronized one-channel) AWGs and an optical quadrature modulator is, by far, the most flexible coherent optical signal generation solution as it does not suffer from the above limitations. All single or multiple carrier modulations, ideal or distorted, can be implemented with one single generator.

AWGs, no matter their bandwidth and sampling rate, always generate electrical signals. High-speed instruments typically generate differential signals as they incorporate direct and inverted outputs. These two complementary outputs are typically obtained from the same DAC block so shape and timing matching are excellent as both outputs share the same data, switching and resistor networks. Direct DAC outputs typically offer the best bandwidth although most instruments incorporate different amplifiers and/or filters that users can select depending on the test requirements. Single-ended signals can be obtained by choosing one of the complementary outputs while the other is properly terminated. Conversion to the optical domain must be done, then, using external blocks.

## Optical Modulators

An optical modulated carrier may basically be obtained in one of three ways:

- Direct quadrature modulation: Two independent baseband signals, one carrying the I component and the other carrying the Q component, are applied to an optical quadrature modulator (Figure 10a).
- Generation of one IF (Intermediate Frequency) signal to feed an optical converter. This arrangement generates two modulated optical carriers, one direct and the other inverted, in the frequency domain. Typically an optical filter should be added to remove one of them (Figure 10b). This generation mode does not require a quadrature optical modulator.
- Generation of two synchronous IF signals to feed two optical converters of which outputs are combined. In this case, baseband signals and carrier phase for each IF signal are adjusted so one of the sidebands (upper or lower) interfere constructively while the other does it destructively (Figure 10c). In this way, one of the sidebands is attenuated and filtering of the signal becomes easier or even unnecessary.

The above methods show advantages and drawbacks. For a given symbol rate the direct IQ modulation method requires about half the sampling rate and electrical signal bandwidth. However, direct IQ modulation involves two separate signal paths for the I and the Q components, including DACs, amplifiers, cabling, and MZMs within the optical modulator. Any difference in amplitude, DC offset, timing, and frequency response will result in unwanted signal distortions such as carrier feed-through, quadrature error and imbalance, and distorted constellations.

IF-based signal generation does not suffer from quadrature related impairments as both components are generated concurrently by the same DAC and independent I and Q signals only exist in the mathematical domain. Optical up-converters are much simpler, cheaper, and easier to align than optical quadrature modulators. Optical signal generation through up-conversion permits using non-coherent optical components in the transmitter as it allows for direct intensity modulation.

Optical quadrature modulators may be available in different formats:

- Parallel MZM blocks known as “Super Mach-Zehnder” structures (SMZ). These blocks typically include the 90° phase shifter required to properly feed the Q optical signal path. The laser source must be applied to an optical splitter to supply the I and the Q branches with equal amplitude, synchronous, optical carriers. The phase of one or both optical signals must be differentially shifted to obtain the required orthogonality before being combined at the end of the process. Any inaccuracy in the optical splitter and combiners, the twin MZM blocks, and the phase shifters will show up in the modulated signal as impairments. Baseband modulating signals are applied directly to the MZM blocks and proper bias voltages must be supplied to them.
- Coherent Optical Modulators Transmitter modules: These are ready to use, factory-aligned systems. IQ baseband signals may not be applied directly to the optical modulation blocks and may go through linearization networks. Additionally, these transmitters handle bias voltages internally.

MZM used in SMZ structures are highly non-linear systems (Figure 3). This is not a significant issue for bi-level modulations such as OOK, BPSK, or even QPSK (where IQ components can be treated as two synchronous BPSK modulations) but it is for higher-order modulations such as QAM16. For optimum transmission power and extinction ratio, applying an undistorted pair of IQ baseband samples will result in a degraded constellation, as the modulating signal will invade the compressed power areas of the device response. Reducing the excursion of the input signals to cover only the more linear sections of the response will impact the transmitter launch power and, as a consequence, the OSNR. Linearity and OSNR are especially important for higher order modulations as the ability to successfully detect symbols carried by the coherent signal depends on the quality of the constellation.

## Baseband Signal Generation

Generation of baseband signals using high-performance AWGs is convenient since AWGs can supply perfect (“golden”) or distorted signals. Linear and non-linear distortions can be easily implemented through the application of mathematical models to the original, undistorted waveforms. Signal processing is applied to the signal before being loaded to the waveform memory so no real-time DSP techniques, extremely difficult at the sampling rates and bandwidths involved, are necessary. Distortions can be added to imperfect components in the transmitter or to compensate for impairments in the quadrature modulator itself. Signals can be easily adjusted by analyzing them using a coherent optical signal analyzer such as the Tektronix OM4000. Some MZMs require rather high voltages swings for full modulation (i.e. 5-8V for LiNbO<sub>3</sub> based modulators) and dual-drive MZMs require a differential input signal. High speed AWGs such as the Tektronix AWG70000 Series can generate full-bandwidth (direct connection) differential signals up to 1 Vpp . Higher voltages are possible through the use of the internal AWG amplifiers. However, these amplifiers tend to limit the analog bandwidth to levels that may be insufficient for the required symbol rates and

modulation bandwidth. If necessary, amplitude may be boosted using widely available optical modulator drivers.<sup>6</sup> These devices come in wide variety of bandwidths and amplitudes and are typically tailored for a given family of optical modulators and data rates.

The final goal of coherent optical links is to increase the overall spectral efficiency of optical networks. Improving the number of bits per symbol is one way to accomplish that goal as signals bandwidth relies heavily on the symbol rate. The same applies to polarization division multiplexing as two independent signals may be transmitted using the same bandwidth. The third way to increase spectral efficiency is to reduce optical carrier spacing in a WDM transmission scheme. Ideally, the bandwidth required to transmit a given symbol speed (or baud rate) B is also B Hz. Theoretically, then, it would be possible to fit optical carriers as close to B Hz (Nyquist BW). For a 50GHz standard ITU grid, baud rate would be limited to 50GBaud, or to 200Gbps for a PM-QPSK signal for a 4b/s/Hz spectral efficiency. In practice, this is not possible with traditional laser modulation techniques with very fast edges as the actual bandwidth of the optical signal will be much larger than the Nyquist bandwidth and the different wavelengths would interfere among them. A trade-off between channel spacing and optical signal filtering is the solution. Channel spacing is selected so there is enough empty spectrum between consecutive channels to ease channel separation at the receiver (i.e. through a WSS, or Wavelength Selective Switch). Nyquist filtering at the transmitter side may be applied in the optical domain although it may be difficult and expensive to obtain the desired characteristics and level of performance. Filtering can also be applied to the electrical signals applied to the modulator. This process, known as baseband shaping, is extensively used in the RF domain as electrical filters are easier to implement and their responses can be better controlled and more repeatable. However, applying filtered signals to non-linear devices such as Mach-Zehnder modulators will result in intermodulation products that will spread the optical power of the signal well beyond the cut-off frequency of the filter (Figure 11).

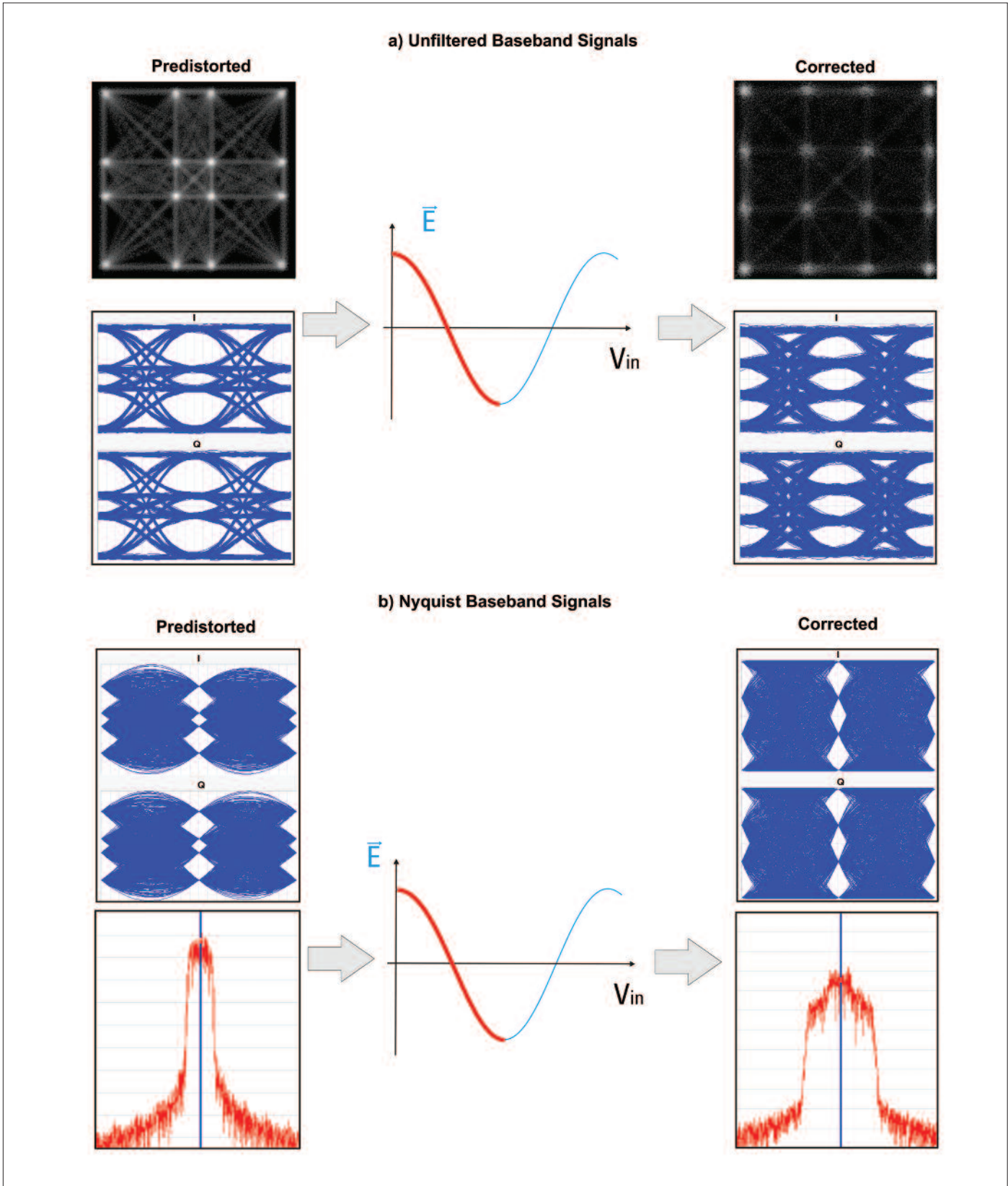

**Figure 11.** Non-linear behavior of MZM is an important issue for complex modulation. For unfiltered, fast baseband signals it is enough to pre-distort the electrical levels to obtain perfect signals (a). For bandwidth limited signals, such the ones used in Nyquist or quasi-Nyquist channels, this is not enough as non-linear distortion results in spectral growth and a increased bandwidth so adjacent channels may be interfered (b).

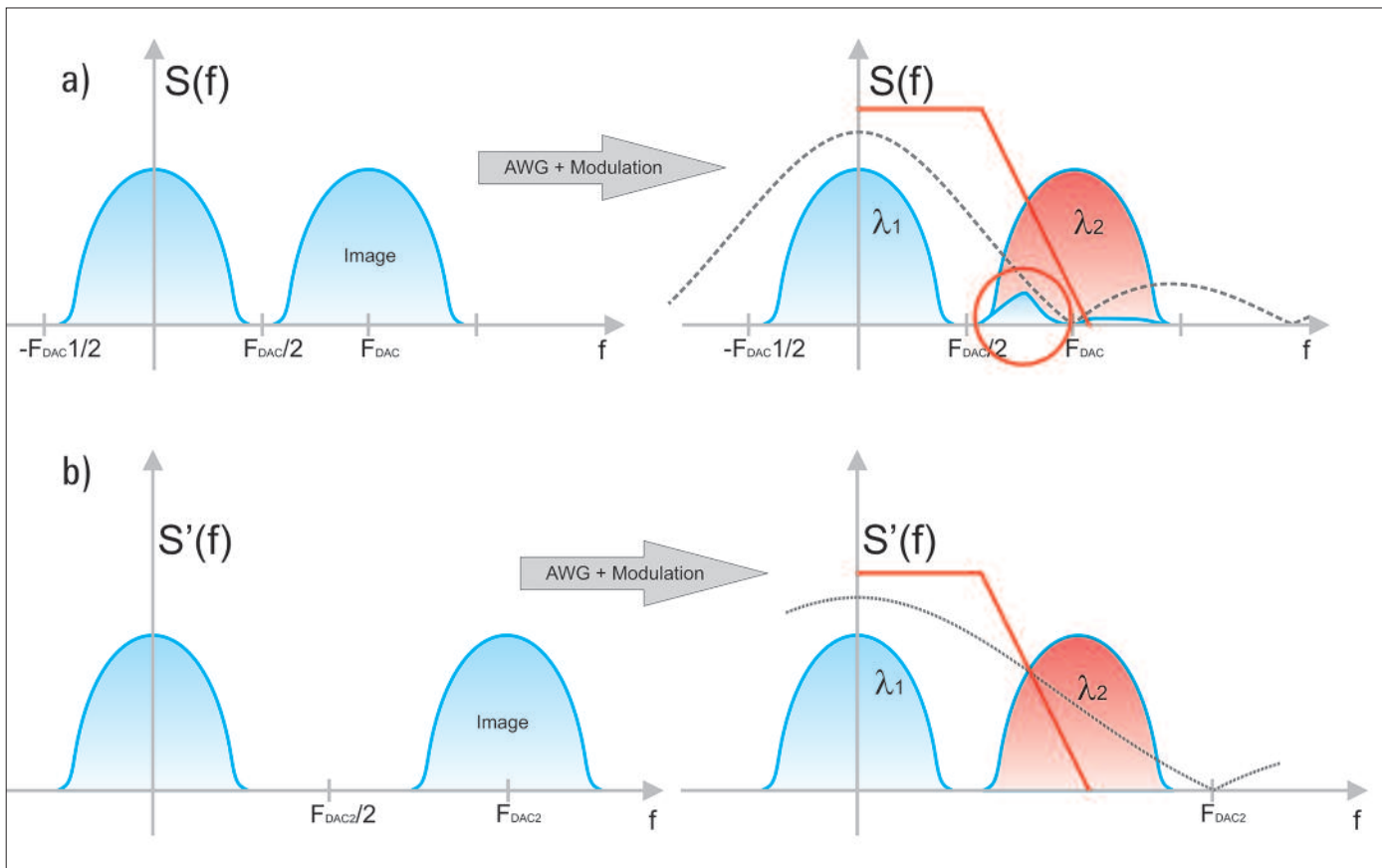

**Figure 12.** The higher the AWG sampling rate the better, even if it is larger than the required for a given signal according to the sampling theorem (2B). Increasing sample rate results in a flatter frequency response and a larger distance to the first unwanted image. In (a), the DAC sampling rate is enough for the signal, but insufficient filtering result in an image interfering the adjacent optical channel (in red). The same filter produces no interference in a higher sampling rate AWG (b) as the image is completely removed from the modulator's output.

AWGs are excellent tools to handle Nyquist channels as filtering can be applied to the waveform before being loaded into the generation memory. At the same time, the filtered signal may be mathematically pre-distorted to compensate for the modulator non-linear response. Some filtering is still necessary, though, as images produced by the DAC will also show up in the output spectrum. Reconstruction filters in order to be effective and simple, must be implemented with as much distance as possible between the main baseband signal and the first image. This can be accomplished through

oversampling. The effect of oversampling depends on the ratio between the bandwidth of the baseband signal and the sampling rate. The baseband signal bandwidth is typically  $(1+\alpha)B$  as actual Nyquist filters (i.e. the popular raised cosine filter) show some roll-off. As an example, for a 28 GBaud signal in a 50GHz WDM grid, an  $\alpha$  parameter as high as 0.75 (resulting in a channel BW = 50GHz) can be implemented with a two channel, 50 GSa/s AWG. In contrast, a 34 GSa/s AWG can just implement  $\alpha$  parameters lower than 0.21 (Figure 12).



## OOFDM Signal Generation

Most of the previous considerations may be applied to OFDM signals as well. OFDM signals are bandwidth limited by nature since the overall bandwidth is calculated as the product of the symbol rate (or the carrier spacing) multiplied by the number of carriers. Non-linear behavior in the modulator also results in very low quality signal so pre-correction must be also applied to this kind of signals. AWGs are a perfect fit here as well.

OFDM signals show a unique characteristic compared to single-carrier modulations: their Peak-to-Average-Power-Ratio (PAPR or Crest Factor) is much higher. It may be as high as 10 dB for an OFDM signal while it is just 1 dB for QPSK or 2 dBs for 16QAM. Linearity is important for OFDM signals as any clipping or distortion results in a degraded constellation with a higher BER equivalent to a considerable power penalty. Using just the more linear section of the modulator response would result in a very low average power signal while invading the non-linear section would result in a low-quality signal. AWGs can apply pre-distortion to linearize the overall DAC/Modulator response obtaining at the same time the maximum launch power and the minimum distortion. An AWG's vertical resolution is extremely important for the generation of signals with high PAPR as the signal spends most of the time in a reduced band of amplitudes. The need to linearize the modulator response further reduces the amplitude band as higher amplitudes get expanded while lower amplitudes get compressed. For an AWG with 6 bit resolution, most of a linearized 10dB PAPR OFDM signal will be synthesized using 1/3 to 1/4 of the total DAC dynamic range so effective DAC resolution will be as low as 4 bit (16 quantization levels). A 10-bit AWG, such as the Tektronix AWG70000 series, will be able to generate such signals with much higher quality as effective resolution for most of the signal will be at least 8 bits (256 quantization levels).

## AWG Desirable Performance and Characteristics for Coherent Optical Signal Generation

### Bandwidth and Sample Rate Requirements

Basic specifications for arbitrary waveform generators were discussed in Section 1. It is important to understand the minimum level of performance that a given application

demands and the way to cope with potential instrument limitations. Probably, the most important single spec for high-speed signal generation is bandwidth. For baseband signals, the minimum bandwidth capable of carrying a given symbol speed or baud rate (BR) is  $BR/2$  Hertz. Ideally, baseband signals with this bandwidth end-up in an optical modulated carrier with a bandwidth equal to the symbol speed. On a first approximation, modulated signal bandwidth must be equal or higher than the actual symbol speed. Unfiltered baseband signals and non-linear behavior in the modulation process will cause the actual bandwidth to be much higher. As an example, baud rate for a 112GBps PM-QPSK signal is 28GBaud so minimum optical bandwidth would be 28GHz while bandwidth for the baseband IQ signals would be at least 14 GHz.

Bandwidth is just part of the story as it must be implemented through a sampling process by the AWG's DACs. Sampling Theorem states that in order to generate a signal with a given bandwidth, the sampling rate in the DAC must be at least twice the bandwidth. In the previous example, this can be translated to about 30-34GS/s. Sampling theory also implies that any DAC working at a given speed will generate images located around multiples of the sampling rate (Figure 12). These images should be removed before being applied to the modulator, as they would create unwanted frequency components in the optical domain, and the intermodulation caused by the modulator non-linear behavior would degrade the OSNR performance of the signal. This filter is known as the reconstruction filter since it tries to recover the original bandwidth-limited signal: an image-free, continuous waveform. In order to be useful, real-world filters must show good in-band flatness, linear phase response (or constant group delay), fast enough roll-off, and good stop band attenuation. Those conditions are difficult to meet if the distance between the end of the baseband signal in the frequency domain is close to the beginning of the first image. Very fast roll-offs typically come at the expense of poor group delay performance and pass-band flatness. The best way to simplify the filter is to increase sampling rate well beyond the sampling theorem requirements. As images are located at much higher frequencies, their amplitude will decrease. For high-enough sampling rates it is possible to implement the image rejection filters in the optical domain or to remove the filter completely (Figure 12b).

## Vertical Resolution Needs

Vertical resolution limits the capability of the AWG to faithfully reproduce the original signal. A poor vertical resolution results in a high level of quantization noise. Even for moderate to low vertical resolution levels, quantization noise may be low compared to other noise sources. However, complex modulated baseband signals require good resolutions for a series of reasons:

- Many modulations require multiple levels, and the lack of resolution in the DAC leads to a poor modulation performance. As an example, a QAM64 requires 8 different levels for each baseband signal. Using a 6-bit DAC with just 64 levels may result in an EVM (Error Vector Magnitude) noise floor close to 2% for an ideal converter. Additional signal processing such as baseband filtering, frequency-response correction and pre-distortion for MZM non-linearity compensation will increase this number to 5% or more. This level of error may be acceptable for simple modulations such as QPSK but it may be too high for higher order modulations such as QAM16 or QAM64. A 10 bit DAC will not have a detectable impact on the EVM performance of the generator.
- Edge positioning accuracy is also influenced by vertical resolution (Figure 8). In other words, jitter will be also impacted by this parameter. A 6-bit, 34GSa/s generator will add up to  $900f_{s_{pp}}$  to the overall jitter based on its vertical resolution, while a 10-bit, 50GSa/s will add just  $40f_{s_{pp}}$ . As a reference, state-of-the-art jitter analysis systems, such as the Tektronix DPO/DSA70000 series,<sup>2</sup> have a jitter noise floor better than 250fs.

## Waveform Memory Size

Waveform memory size (or record length, RL) is also extremely important for many applications.<sup>11</sup> For waveforms carrying digital information, such as complex modulated signals, record length directly translates into a time window ( $TW = RL/SR$ ) and, consequently, to a given number of symbols and bits. The capability of generating a high number of non-repetitive bits is important when meaningful line/channel coded data must be transmitted or when stressful data patterns are required.<sup>3</sup> A good example of this is the generation of pseudo-random binary sequences (PRBS). These

sequences repeat every  $2^N - 1$ , where N is a given integer. The number of consecutive zeros or ones in the sequence is limited by N so the greater the N, the more stressful and realistic the sequence will appear to the DUT/SUT.

For 28GBaud QPSK baseband signals generated using a two-channel AWG, an instrument with 2MSamples of memory per channel will be able to generate sequences up to  $2^{20} - 1$  bits long while a generator with an 8GSample memory would be capable of generating PRBS of  $2^{32} - 1$  bits long. The capability of simulating very infrequent errors or glitches also depends on the waveform memory size as well as on the number and size of waveforms that can be stored or sequenced in the AWG without the need to reload and/or stop signal generation.

Waveform memory size is also important for noise emulation. The unique capability of AWGs to generate any waveform shape can be used to generate several superimposed signals simultaneously. This method can be used to add noise with controlled and repeatable characteristics to a signal. Controlled, realistic noise may be used to test the behavior of the receiver in actual working conditions. A typical test model implies adding Gaussian noise with a given average power and look for errors at the receiver. The error levels that can be expected from a receiver depend on the OSNR and the robustness of the FEC scheme being applied. In today's links, even poor OSNR levels result in very low after-FEC errors. Low error rates require capturing errors over a long sequence of data. Extremely long, even unlimited, sequences of data can be easily obtained through seamless looping of a limited sequence. Although this approach is valid for data sequences, the complete waveform, and the noise contained in it, repeats all the time, so errors will show up in the same locations over and over again. In order to have a statistically correct noisy signal a non-repeating waveform at least 10 times longer than the average distance between errors is required. The data within the waveform may be repeated but not the noise. Following these criteria, a 100Gbps signal generated at 50GSa/s, 16GSample record length AWG can generate statistically correct noise for BER levels up to  $3.1 \times 10^{-10}$ , while an AWG with 34GSa/s and 2MSamples record length, can only emulate realistic noise behavior for BER levels around  $1.7 \times 10^{-6}$  or worse.



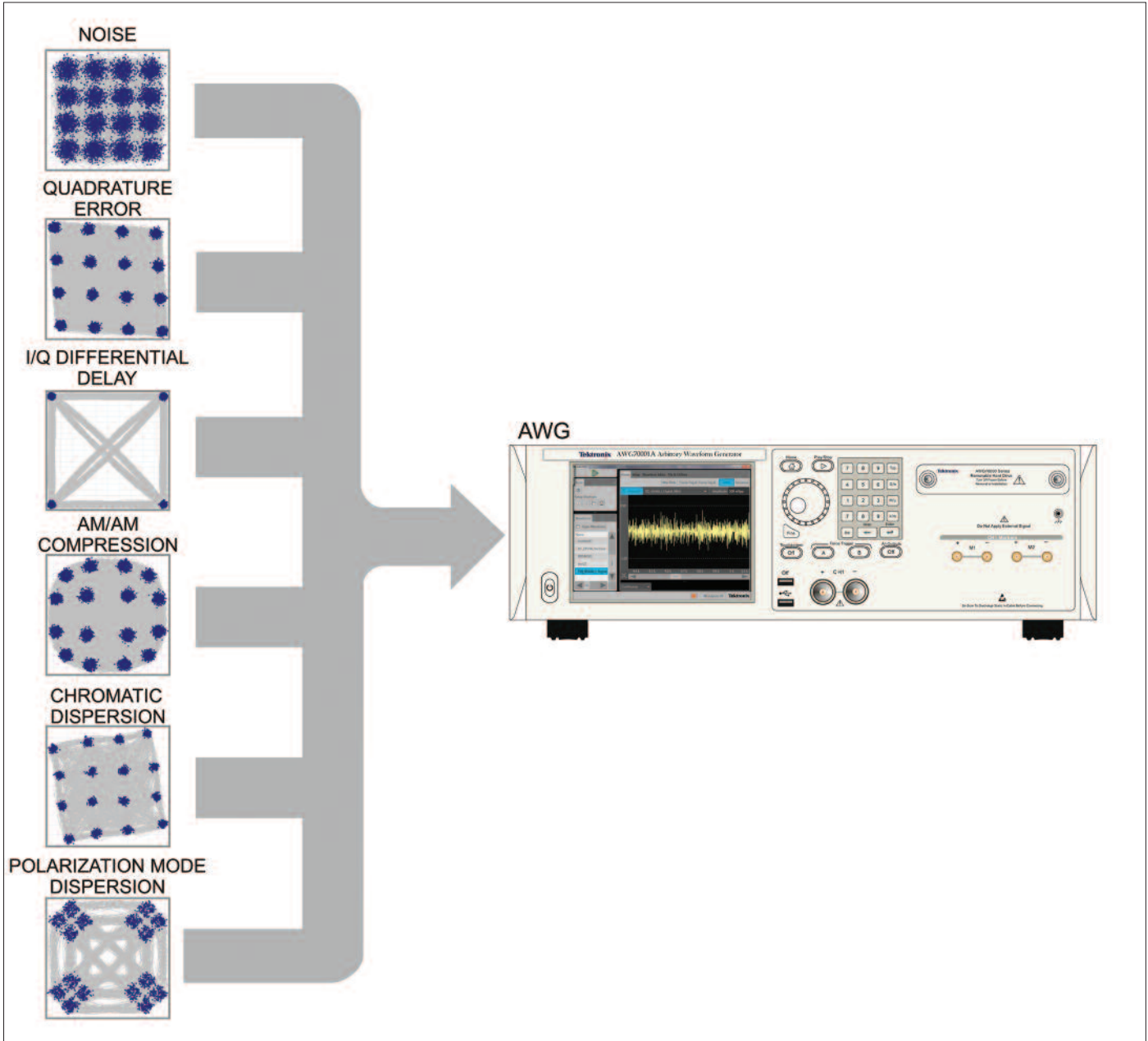

**Figure 13.** AWGs can produce a large variety of distortions, linear and non-linear, applied to modulated signals. These can emulate issues in the transmitter, the receiver, and even the link or the network. The same capability can be used to compensate for such distortions and obtain better-quality signals from poor-quality components or links.

## Linear and Non-linear Distortion Addition and Compensation

### Ideal, Distorted, and Corrected Waveforms

AWGs can generate near perfect or impaired signals. Just as noise can be added, linear and non-linear distortions can be generated by mathematically pre-processing the waveforms before being downloaded to the waveform memory and generated through the DAC (Figure 13). Sometimes, it is necessary to compensate for distortions introduced by the instrument itself and/or external system components such as cabling, amplifiers, modulators, and even complete optical networks. Regarding instrument performance, this may be improved by applying correction models obtained after careful calibration and characterization.<sup>13, 14</sup> For IQ signal generation and dual polarization multiplexing support, channel matching in terms of frequency response (amplitude and phase), skew, and channel-to-channel jitter, is extremely important to obtain good results. Distortions may be classified in two groups: linear and non-linear.

Linear distortions include many aspects. The most relevant of which are:

- **Frequency response:** Magnitude and phase response vs. frequency for AWGs consists of the combination of the ideal  $\sin(f)/f$  DAC response, the analog response of the output circuitry, and other external elements such as cables, connectors, etc. For IQ generation, where two channels are required, it is also important to account for the differential frequency response. Typically, it is easier to obtain a good match between two channels in the same instrument than two channels from different instruments although careful alignment can result in similarly equivalent performance. Frequency response calibration of AWGs is relatively straight forward using an oscilloscope (real-time or equivalent time) with enough bandwidth and a very well characterized response. The Tektronix DPO/DSA70000 series scopes are ideal for that purpose as they show extremely flat magnitude response, excellent group delay consistency over the full bandwidth, extremely low acquisition jitter, and unparalleled channel-to-channel matching (Figure 14).

Single tone or multi-tone calibration signals offer a good performance in terms of accuracy and dynamic range.<sup>13, 14</sup> Once the frequency response has been obtained, it can be reversed and applied to the signal to be corrected. Correction may be also used to extend the frequency coverage of any AWG, as attenuated high frequency components can be pre-emphasized. However, frequency extension comes at a price: the higher amplitude high-frequency components can only be boosted by reducing the amplitude of the lower components. The result is a reduction of the output amplitude and a reduction of the SNR. In practice, correction should not be applied at frequencies where attenuation is larger than 6/10dB.

- **Channel-to-channel delay (skew):** As symbol rates increase, any time difference between the I and Q base-band signal becomes more apparent. Skew is a bi-product of the frequency response characterization of the two channels. If the same phase reference (i.e. trigger source) is used for the characterization of both channels, subtraction of the two group delay responses will reveal the skew as a function of the frequency. A similar result may be obtained by using an oscilloscope to align two fast edges generated synchronously by the two channels. Alignment of both edges can be adjusted through the delay controls available in high performance AWGs so, in most situations, it is not necessary to use matched cabling. Other alignment methods use optical signal analyzers such as the Tektronix OM4000 series as the shape of the transitions between symbols in the constellation are very sensitive to skew.
- **Chromatic Dispersion (CD):** From the AWG perspective is simply a special case of linear distortion affecting only the phase frequency response. A given CD level can be emulated by processing the phase response (that can be easily derived from the CD characteristics of the fiber), obtaining the corresponding impulse response, and convolving it to the undistorted signal. Applying the reverse frequency response can be used to compensate for the CD present in a fiber. CD generated by mathematical distortion at the AWG is more repeatable, flexible, and more convenient than using long runs of fiber.

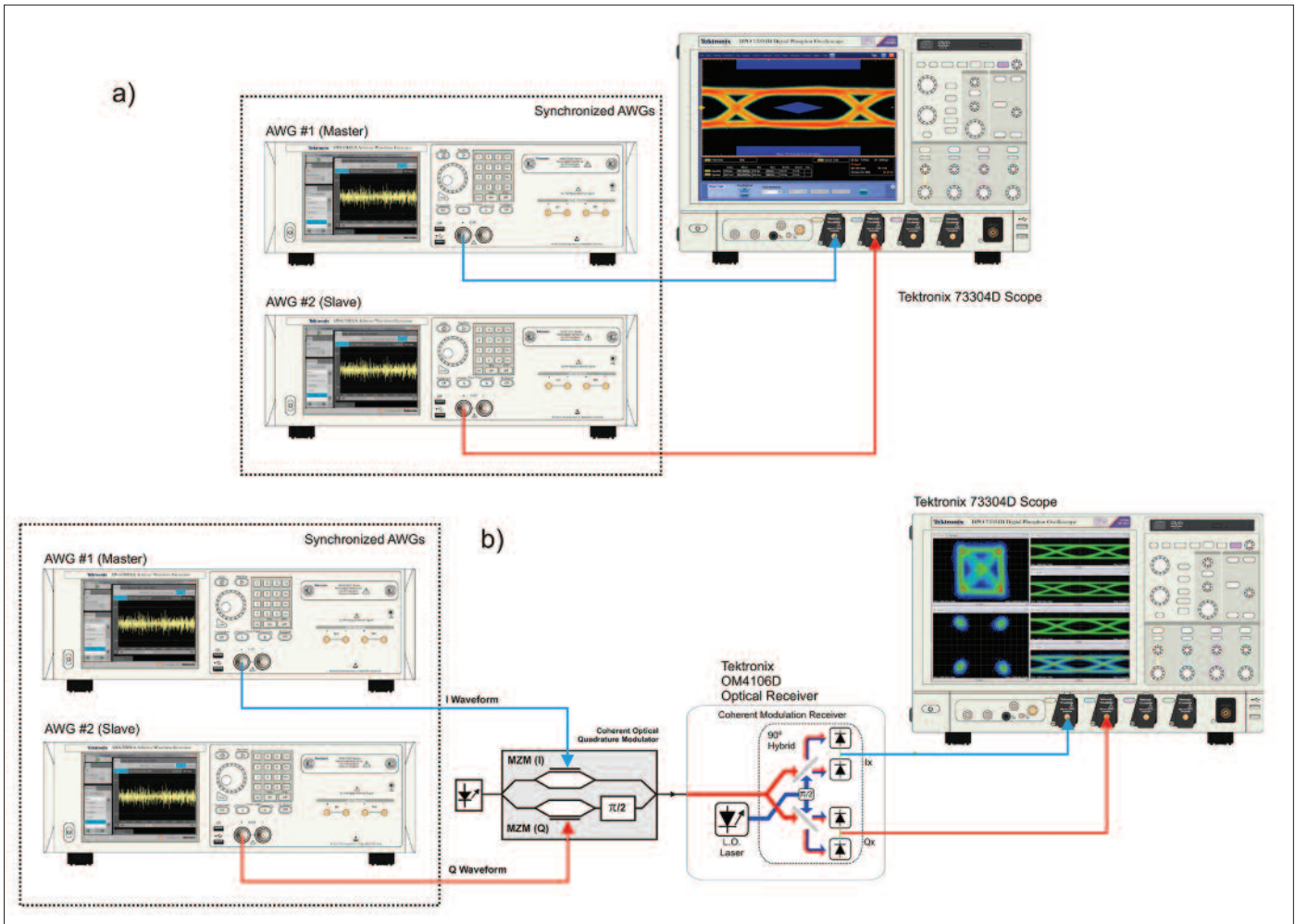

Figure 14. Joint channel, or even instrument, calibration and correction are important to obtain the best results. Electrical-only calibration (a) is a straight-forward operation if the right measurement devices, such as the Tektronix DPO/DSA70000 oscilloscopes, series are available. Complete system (including the optical components) calibration and characterization require a Optical Modulation Analyzer (b) such as the Tektronix OM4106D.

- **Polarization Mode Dispersion (PMD):** From an AWG perspective, PMD is just a special case of channel impulse response. In this particular case PMD can be emulated by adding two versions of the undistorted signals with the right relative amplitudes and delay. PMD depends on physical and environmental conditions of the fiber and it varies over time as conditions change. Emulating PMD variation over time (i.e. to test the tracking performance of a PMD compensation system at the receiver) is possible through an AWG where the minimum frequency component that can be emulated is the inverse of the maximum time window. For the AWG70000 Series with 16GSamples record length and 50GSa/s sampling rate, minimum frequency component (other than DC) is around 3Hz. Commercial PMD compensators<sup>15</sup> can keep track of variations of the PMD of a few hundred ps/s and tracking ranges of tens of ps, well within the range of what is possible for the AWG70000 Series at its maximum sampling rate. For a 2MSample, 34GSa/s AWG the minimum frequency PMD will be 17 kHz, well out of the range of commercial PMD compensators.
- **Linear constellation distortions:** This distortion category includes carrier feed-through, quadrature error and quadrature imbalance. These distortions may originate at the electrical baseband signals or at the optical modulator. The overall effect of the distortion can be measured with an optical modulation analyzer (OMA). Carrier feed-through (residual carrier) and quadrature imbalance (different amplitude of the signal in the I and the Q axis) can be compensated for, or emulated by changing the offset and amplitude of each AWG channel. Quadrature error, which results from non-orthogonal optical carriers applied to the I and Q components, can be compensated for relatively small angles or emulated by synthesizing new I and Q components after applying the right compensation matrix:
- **Reflections in the signal path:** Signals may be composed of a single direct and one or any number of reflected signals. Reflections may happen at the electrical and/or optical level. Given the high bandwidth of the baseband signals, any impedance mismatch in the signal path will result in undesirable reflections. While electrical connections tend to be short, reflections in the optical domain may be extremely long. However, for the typical 28 GBaud complex modulated optical signals, both are often larger than one symbol period in terms of distance. Electrical reflections, at a relatively short distance, may be characterized through signal path calibration, as the frequency response (in magnitude and phase) of the channel will include their effects. Emulating or compensating them with an AWG is fairly straight forward, as it requires applying the linear model of the signal path (emulation) or its reverse (compensation). Optical reflections, located much farther away, may be easily emulated but their compensation is extremely difficult, if not impossible, for long fiber runs. Reflections vary over time as they depend on the physical characteristics of the link including connectors, splices, propagation speed, temperature, aging, etc.

$$I' = I \times \cos(\alpha/2) + Q \times \sin(\alpha/2)$$

$$Q' = Q \times \cos(\alpha/2) + I \times \sin(\alpha/2)$$

Here  $\pi$  is the quadrature error angle, for small  $\alpha$  the above expression may be simplified:

$$I' = I + Q \times \alpha/2$$

$$Q' = Q + I \times \alpha/2$$

## Non-linear Distortions

Linear distortions do not create new frequency components in the signal; they just change the existing ones. Non-linear distortions do the opposite: they create new frequency components. This is especially important to know when multiple wavelengths are being transmitted simultaneously through the same fiber (DWDM). Even properly filtered modulated signals, when non-linearly distorted, can trespass the limits of each channel causing interference and degraded performance of the link (Figure 11a). Distortions in the Mach-Zehnder modulators have been previously discussed and AWGs allow for easy compensation through the use of pre-distorted constellations. For single, fast, unfiltered baseband signals, just distorting the constellation may be enough to get a proper test signal. For Nyquist or Quasi-Nyquist DWDM though, the complete signal must be pre-distorted so spectral growth does not occur and interference in adjacent channels remains limited (Figure 11b).

Distortions in the AWG may be mathematically applied to samples through the use of a distortion function. A simple way to model distortion is a polynomial of a given order. Polynomial terms with odd degree result in symmetrical distortion with respect to the 0 level, while terms of even degree result in asymmetrical distortions. For properly polarized MZMs, dominant terms are those of odd degree, reflecting the symmetry of the non-linear response of the device. For optical quadrature modulators, two MZM are applied to each baseband signal so pre-distortion must be applied to each component independently.

Once the optical signal has been modulated, any non-linearity will be applied to the combined, modulated signal. A good way to model the effects of non-linear devices such as optical amplifiers is, again, to use polynomial models. It is better to model the influence of the instantaneous amplitude at the input on the output signal in two components: amplitude itself (or AM/AM distortion) and phase (or AM/PM distortion). Chirp could be seen as special case of AM/PM distortion. AWGs can emulate or compensate for those non-linear behaviors as well but correction must be applied to the overall signal instead as it is the overall amplitude and phase of the signal what must be taken into account.

Laser linewidth is another source of non-linear distortion. Its effect is very similar to the phase noise distortion commonly found in the RF world. Ideally lasers used in coherent optical transmission should show excellent frequency coherence since part of the signal information is carried by the phase. In practice, optical receivers must be capable of tracking the instantaneous phase of the carrier in a process known as carrier recovery. Carrier recovery may be done at the optical domain through expensive optical DLL blocks or at the electrical level by applying DSP techniques to recovered baseband signals in a heterodyne or intradyne receiver. Being able to generate signals with a user-defined linewidth is a relatively easy task for a two channel AWG if a good quality laser source is applied to an optical quadrature modulator (Figure 15). A given linewidth can be emulated by applying a convenient  $\phi(t)$  function to the baseband signals:

$$I'(t) = I(t) \times \cos \phi(t) - Q(t) \times \sin \phi(t)$$

$$Q'(t) = Q(t) \times \cos \phi(t) + I(t) \times \sin \phi(t)$$

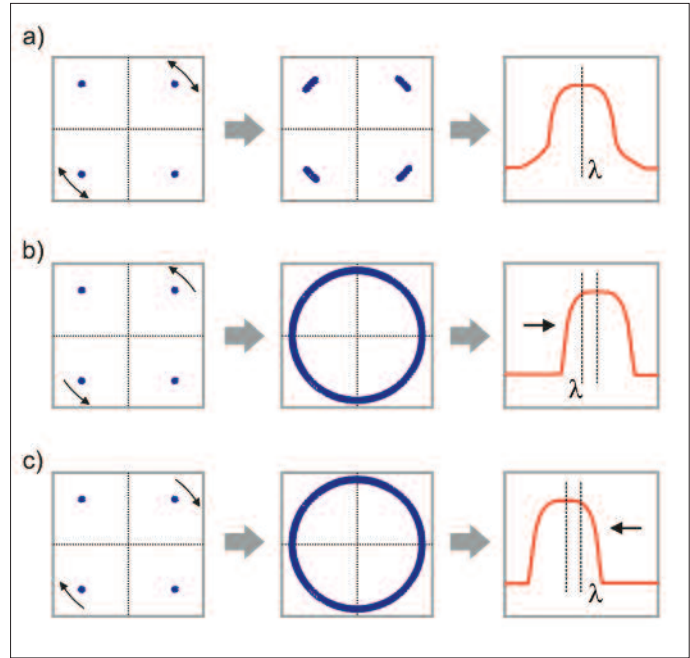

**Figure 15.** Laser linewidth can be also emulated electrically by rotating the constellation back and forth resulting in phase noise (a). Clock-wise (c) or counter-clockwise (b) constant speed rotation of the constellation can be used to shift the  $\lambda$  of the optical carrier in either direction.

In particular,  $\phi(t)$  may be a sinusoidal signal of a given amplitude and frequency so the behavior and operating envelope of the carrier recovery system may be stressed and characterized. Central frequency of the optical signal may be controlled in this way by applying  $\phi(t) = 2\pi f t$  what is equivalent to shift the signal in the optical domain and rotate the constellation at the baseband level. Direction of the frequency shift and constellation rotation (clockwise or counter-clockwise) will depend on the sign of the  $f$  parameter.

The capability to control the instantaneous amplitude and phase of an optical carrier through I and Q baseband signals connected to an optical quadrature modulator opens the door to generate traditional OOK, direct modulated signals as well. Quadrature modulation techniques may be used to generate signals with a controlled and repeatable level of optical noise, spectral linewidth, extinction ratio, and chirp, among other effects.

All the above linear and non-linear distortions or corrections may be applied to virtually any standard or user-defined single-carrier or OFDM modulation scheme using the Tektronix RFXpress software, available for all the Tektronix AWGs.



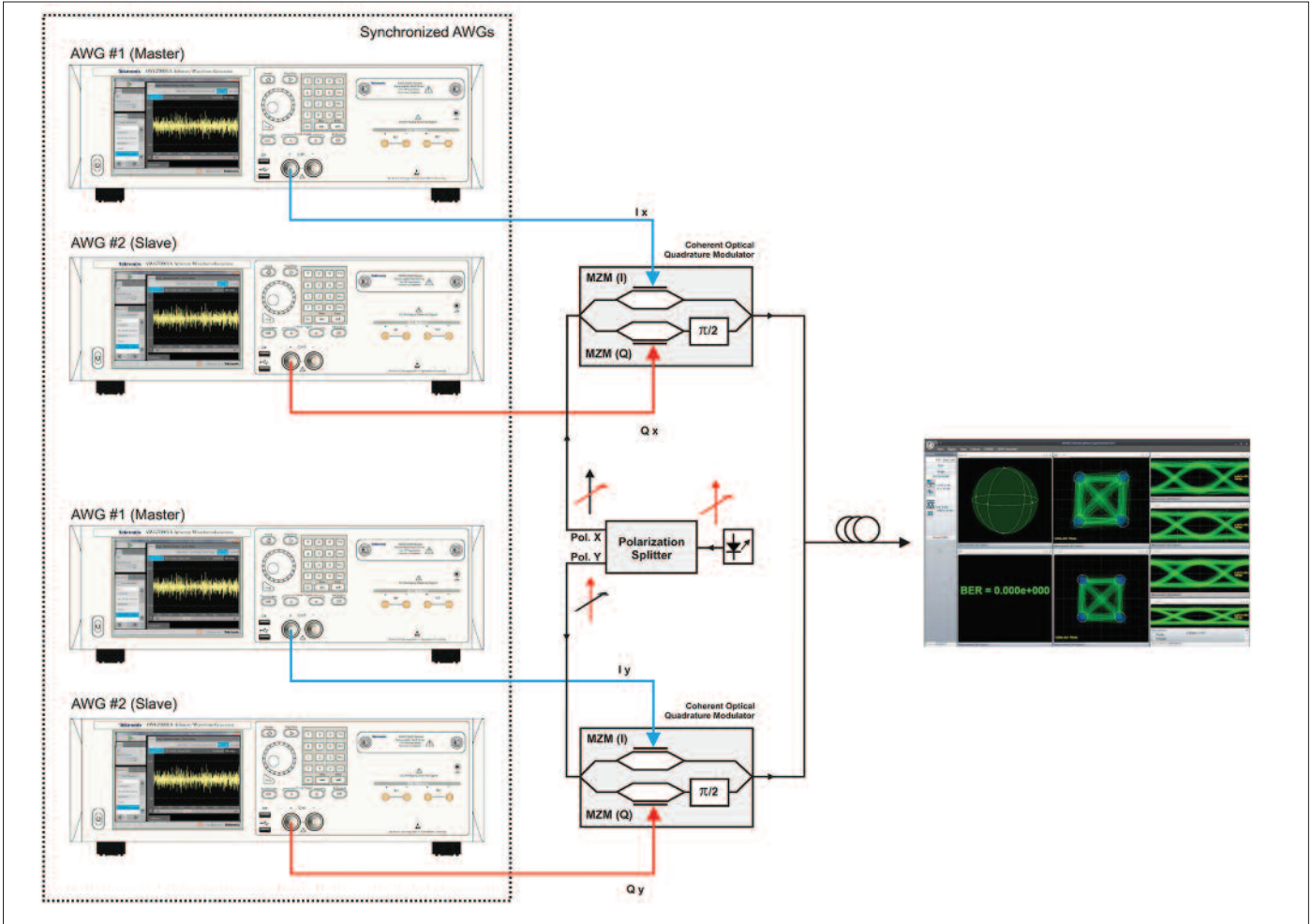

**Figure 16.** Complete Polarization Division Multiplexed transmitter emulation requires 4 synchronized AWG channels to generate the  $I_x$ ,  $Q_x$ ,  $I_y$ , and  $Q_y$  baseband signals. Adequate control of those 4 signals can be used to emulate any static or dynamic SOP (State-Of-Polarization).

## Signal Generation for Polarization Division Multiplexing (PDM)

### PDM Requirements

Coherent optical transmission opens the door to transmit two independent signals in each polarization. Typically, those two signals are synchronous and share the same modulation scheme although they carry independent data. Generating such signals requires two pairs of IQ signals, for a total of four baseband electrical signals (Figure 16). Therefore, complete control of these baseband signals requires four (4) independent arbitrary waveform generator channels.

Given the characteristics of the signals, especially their bandwidth, and the current state of AWG technology, full-featured PDM transmitters can be only emulated through two two-channel or four one-channel ultra-high bandwidth AWGs. Synchronization between them must be kept up to a fraction of the duration of a symbol (35 ps for a 28 GBaud signal). In practice, timing alignment between all the channels should be also a fraction of the sampling period (20 ps for a 50GSa/s AWG). The AWG70000 Series generators allow this level of synchronization with better than 5ps timing accuracy through a simple synchronization scheme and a straightforward calibration process.



## State-Of-Polarization (SOP) Emulation

PDM signals may be orthogonal in the polarization domain when they abandon the modulator. But, unless polarization-maintaining fiber is used, both polarizations will mix-up as they travel through the optical link, especially if it is a long-haul connection. The way both polarizations interfere can be characterized through a linear model consisting in a matrix (Jones Matrix) that relates the state of polarization (or SOP) at the output with the SOP at the input. Receivers must be able to cope with this situation by estimating SOP and recovering the original signal. Again, AWGs are really helpful to stress receivers as they can generate modified baseband signals implementing any desired Jones Matrix. The resulting optical signal must be applied through polarization maintaining fiber. It is even possible to avoid all the optical components by directly emulating the output of the 90° hybrids used in most coherent optical receivers and feeding the four signals to the DSP block processing and recovering the original signals.

In the real world, SOP is not constant as it is affected by multiple physical factors acting on the fiber. Estimators at the receiver must track relatively slow changes in SOP over time. State-of-polarization can be shown in a convenient form through the Poincaré Sphere. SOP evolution over time can be seen as a trajectory on the Poincaré Sphere (Figure 17). AWGs can emulate any trajectory although it must be a closed one to generate continuous signals without any wrap-around artifact glitch (reference) than can be seamlessly looped.

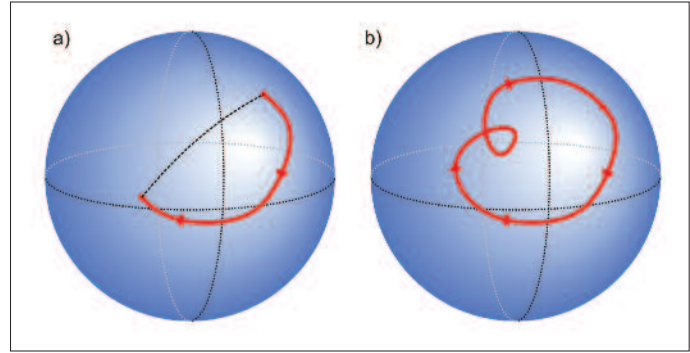

**Figure 17.** SOP can be conveniently represented in the so-called Poincaré Sphere. PDM receivers must keep track of the instantaneous SOP which evolves rather slowly over time. AWGs can produce any trajectory of the SOP over the Poincaré Sphere in order to stress receivers. However, to be useful, record length must be extremely long to reproduce speeds and frequencies within the range of the receiver-under-test' SOP tracking system. For continuous signal generation, which requires looping the same waveform, open trajectories like the one shown in (a) are not acceptable as the instantaneous discontinuity will confuse the receiver. SOP trajectories must be closed, like the one in (b), for continuous, seamless signal generation.

There are some important constraints regarding speed in terms of amplitude and speed of the trajectory depending on the time window that the AWG can implement. The size of the waveform memory is the important factor here. For the Tektronix AWG70000 Series, with up to 16GSa waveform memory, SOP trajectories can last as long as 320ms at the maximum sample rate (50GSa/s). A maximum circle trajectory (2 radians) will result in a 20 radians/s speed, well within the range of most SOP tracking systems in commercial receivers.<sup>15</sup> This level of performance is a must for realistic SOP emulation. Instruments with shorter waveform memories can only emulate static SOPs so they are not useful to stress SOP tracking systems at the receiver.

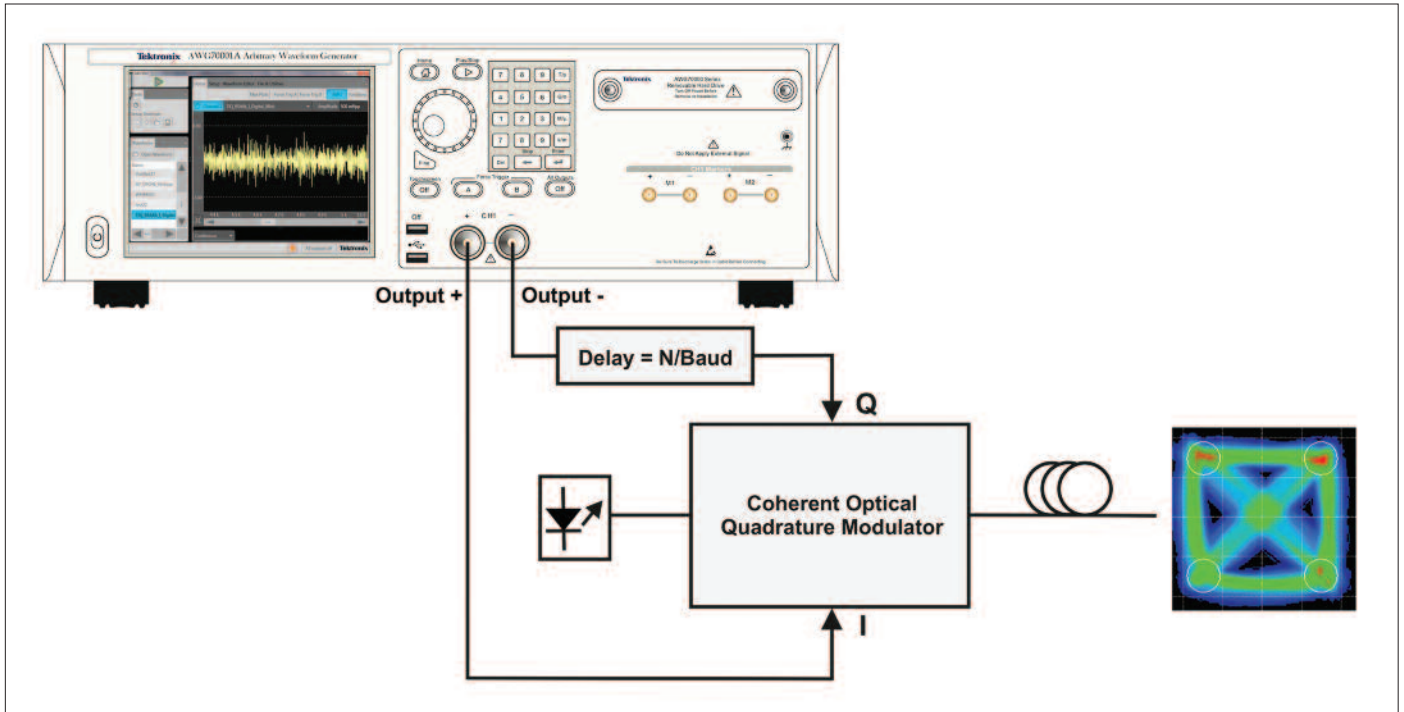

**Figure 18.** Some modulation schemes may be generated by single channel instruments. Uncorrelated I and Q baseband signals may be obtained by delaying one of them by an integer number of symbol times. Here, the two complementary outputs of a Tektronix AWG70000 series generator are used in such an arrangement, providing for higher amplitude signals than those coming out from a power splitter fed by one of the outputs.

### Channel Count Reduction

Generating multiple high-bandwidth channels is not only tricky, but can also be expensive. Depending on the type of signal to be generated and the baud rate involved, up to four instruments may be required to generate a single wavelength. Complete control of a PDM signal including modulation scheme, linear and non-linear distortions, SOP, etc, requires four fully independent channels. However, for basic signal generation, it is possible to generate undistorted signals using only one one-channel arbitrary waveform generator. In most situations, I and Q baseband signals are similar and independent one from the other. QPSK or QAM signals are good

examples of this, as baseband signals consist in independent BPSK or PAM modulated signals. Applying the same BPSK or PAM signals to both inputs in an optical quadrature modulator does not result in the desired constellations, as only the symbols located in one of the diagonals will be excited and the resulting signal will also be a BPSK or QAM with just a difference carrier phase. The complete constellation may be obtained for a random-like sequence of symbols by delaying the I and the Q components by an integer number of symbol periods (Figure 18). Randomness of the symbol sequence will make sure that all the symbols in the constellation will be evenly excited. In order to get good quality

constellations from the statistical standpoint, the delay between the two components must be long enough to avoid any memory effect in the signal. Inter-symbol interference (ISI) of any kind should be negligible after the applied delay. ISI may come from different sources such as Nyquist filtering and reflections. Generally speaking, 5 to 10 symbol periods should be enough for most situations. Typically, the signal out of the generator would be supplied to a power splitter and a differential delay (i.e. through appropriate cabling) would be applied to each output. Differential delay must be accurate enough to a fraction of the symbol period. If the modulator does not require differential signaling and the AWG incorporates a differential output, as the AWG70000 series do, it is possible to use the direct signal as the I component and a delayed version of the inverted signal as the Q component. In this way, the attenuation caused by the power splitter can be avoided. For PDM signal generation the same method may be used but it is also important to make sure that modulated signals travelling in each polarization are uncorrelated. This condition may be met by adding additional delays to the I and Q components. Alternatively, a single modulated optical signal may be split in two orthogonal polarizations and, after delaying one of them by an integer number of symbols, recombining them to obtain the final uncorrelated pair of DPM signals.

## Conclusions

Coherent optical signal generation is one of the more demanding applications for an Arbitrary Waveform Generation. The requirements in terms of number of channels sampling rate, bandwidth, record length, and timing and synchronization quality can be only met by the highest performance instruments, such as the Tektronix AWG70000 series. The unique capability of generating ideal or distorted signals and the ease to add new modulation schemes and signal processing algorithms without the need to add any extra hardware make AWGs the ideal tool for coherent optical communication research and development.

## References

- 1) Physical Layer Testing of 100Gb/s Communication Systems, Tektronix Application Note. Literature number 65W-28494-1
- 2) Choosing an Oscilloscope for Coherent Optical Modulation Analysis, Tektronix Technical Brief. Literature number 85W-28243-0
- 3) Automating Bit error Rate Measurements of Complex Modulated Signals, Tektronix Application Note. Literature number 85W-27725-0
- 4) Trigonometric Transforms for High-Speed Optical Networks: All-Optical Architectures and Optical OFDM, Michela Svaluto, Journal of Networks, Vol. 5 Num. 11, November 2010
- 5) 1.5-Tb/s Guard-Banded Superchannel Transmission over 56x100 km (5600 km) ULAF Using 30 GBaud Pilot-Free OFDM-16QAM Signals with 5.75b/s/Hz Net Spectral Efficiency, Xiang Liu et al., ECOC 2012 Papers.
- 6) OA3MMQM Data Sheet, 32 GBaud Quad Input Linear Modulator Driver, Centellax
- 7) XYZ of Signal Generators, Tektronix Primer. Literature number 76W-16672-5
- 8) DAC Interleaving in Ultra-High-Speed Arbs, Joan Mercade, Evaluation Engineering Article, December 2009
- 9) Unwrapping Wireless Signals, Joan Mercade, Test & Measurement World Article, January 2007
- 10) Ruling the Waves, Joan Mercade, Evaluation Engineering Article, July 2004
- 11) Maximize a Waveform Generator's Memory, Joan Mercade, Test&Measurement World Article, May 2011
- 12) RFXpress Advanced RF/IF/IQ Waveform Creation and Editing Software for Tektronix Arbitrary Waveform Generators, Tektronix Technical Brief. Literature number 76W-20882-1
- 13) Calibrate, Characterize and Emulate System Using RFXpress in AWG Series, Tektronix White Paper. Literature number 76W-24426-0
- 14) Creating Calibrated UWB WiMedia Signals, Tektronix Application Note. Literature number 76W-20861-1
- 15) PMDBuster Data Sheet, Polarization Mode Dispersion Compensator, General Photonics

## Contact Tektronix:

**ASEAN / Australia** (65) 6356 3900  
**Austria\*** 00800 2255 4835  
**Balkans, Israel, South Africa and other ISE Countries** +41 52 675 3777  
**Belgium\*** 00800 2255 4835  
**Brazil** +55 (11) 3759 7627  
**Canada** 1 (800) 833-9200  
**Central East Europe and the Baltics** +41 52 675 3777  
**Central Europe & Greece** +41 52 675 3777  
**Denmark** +45 80 88 1401  
**Finland** +41 52 675 3777  
**France\*** 00800 2255 4835  
**Germany\*** 00800 2255 4835  
**Hong Kong** 400-820-5835  
**Ireland\*** 00800 2255 4835  
**India** +91-80-30792600  
**Italy\*** 00800 2255 4835  
**Japan** 0120-441-046  
**Luxembourg** +41 52 675 3777  
**Macau** 400-820-5835  
**Mongolia** 400-820-5835  
**Mexico, Central/South America & Caribbean** 52 (55) 56 04 50 90  
**Middle East, Asia and North Africa** +41 52 675 3777  
**The Netherlands\*** 00800 2255 4835  
**Norway** 800 16098  
**People's Republic of China** 400-820-5835  
**Poland** +41 52 675 3777  
**Portugal** 80 08 12370  
**Puerto Rico** 1 (800) 833-9200  
**Republic of Korea** +822-6917-5000  
**Russia** +7 (495) 7484900  
**Singapore** +65 6356-3900  
**South Africa** +27 11 206 8360  
**Spain\*** 00800 2255 4835  
**Sweden\*** 00800 2255 4835  
**Switzerland\*** 00800 2255 4835  
**Taiwan** 886-2-2656-6688  
**United Kingdom\*** 00800 2255 4835  
**USA** 1 (800) 833-9200

\*If the European phone number above is not accessible, please call +41 52 675 3777

Updated March 2013

### For Further Information

Tektronix maintains a comprehensive, constantly expanding collection of application notes, technical briefs and other resources to help engineers working on the cutting edge of technology. Please visit [www.tektronix.com](http://www.tektronix.com)



Copyright © 2013, Tektronix. All rights reserved. Tektronix products are covered by U.S. and foreign patents, issued and pending. Information in this publication supersedes that in all previously published material. Specification and price change privileges reserved. TEKTRONIX and TEK are registered trademarks of Tektronix, Inc. All other trade names referenced are the service marks, trademarks or registered trademarks of their respective companies.  
03/13 DM/ 76W-29051-0

**Tektronix**<sup>®</sup>

