



DGS-9168GP-AIO_S

Industrial desktop type 24-port managed Gigabit Ethernet switch with 16x10/100/1000Base-T(X) and 8x100/1000Base-X, SFP socket, LC connector bypass

Features

- Supports O-Ring (recovery time < 30ms over 250 units of connection) and MSTP(RSTP/STP compatible) for Ethernet Redundancy
- Open-Ring support the other vendor's ring technology in open architecture
- O-Chain allow multiple redundant network rings
- Support standard IEC 62439-2 MRP (Media Redundancy Protocol) function
- Provide two optical bypass function
- Support IEEE 1588v2 clock synchronization
- Supports IPV6 new internet protocol version
- Support Modbus TCP protocol
- Support IEEE 802.3az Energy-Efficient Ethernet technology
- Provided HTTPS/SSH protocol to enhance network security
- Supports SMTP client
- Supports IP-based bandwidth management
- Supports application-based QoS management
- Supports Device Binding security function
- Supports DOS/DDOS auto prevention
- IGMP v2/v3 (IGMP snooping support) for filtering multicast traffic
- Supports SNMP v1/v2c/v3 & RMON & 802.1Q VLAN Network Management
- Support ACL, TACACS+ and 802.1x User Authentication for security
- Supports 9.6K Bytes Jumbo Frame
- Multiple notification for warning of unexpected event
- Web-based ,Telnet, Console (CLI), and Windows utility (Open-Vision) configuration
- Support LLDP Protocol
- Rigid IP-30 housing design

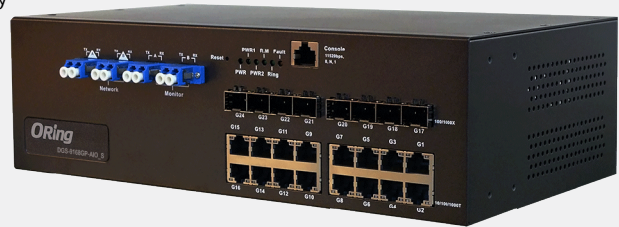

Introduction

DGS-9168GP-AIO_S is managed redundant ring Ethernet switch with 16x10/100/1000Base-T(X) ports and 8x100/1000Base-X SFP ports. With completely support of Ethernet Redundancy protocol, O-Ring (recovery time < 30ms over 250 units of connection) / Open-Ring / O-Chain / MRP / Fast Recovery and MSTP (RSTP/STP compatible) can protect your mission-critical applications from network interruptions or temporary malfunctions with its fast recovery technology. And support wide operating temperature from -40 °C to 70 °C. DGS-9168GP-AIO_S includes 2 sets of bypass ports that protect the network from failures and Network maintenance by ensuring network integrity during power loss. DGS-9168GP-AIO_S can also be managed centralized and convenient by Open-Vision, Except the Web-based interface, Telnet and console (CLI) configuration. Therefore, the switch is one of the most reliable choice for highly-managed and Fiber Ethernet power substation and rolling stock application.

- **O-Ring** : O-Ring is ORing's proprietary redundant ring technology, with recovery time of less 30 milliseconds and up to 250 nodes. The O-Ring redundant ring technology can protect mission-critical application from network interruptions or temporary malfunction with its fast recover technology.
- **Open-Ring** : Open-Ring is an enhanced redundant technology that makes ORing's switches compatible with other vendor's proprietary redundant ring technologies. It enables ORing's switches to form a single ring with other vendor's switch. In cases where the ring is setup using proprietary technology, ORing offers a compatibility service where ORing can make its switches compatible with your particular network requirements.
- **O-Chain** : O-Chain is the revolutionary network redundancy technology that provides the add-on network redundancy topology for any backbone network, O-Chain allows multiple redundant network rings of different redundancy protocols to join and function together as a larger and more robust compound network topology. O-Chain providing ease-of-use while maximizing fault-recovery swiftness, flexibility, compatibility, and cost-effectiveness in one set of network redundancy topology.
- **MRP** : Media Redundancy Protocol (MRP) is a data network protocol standardized by the IEC 62439-2. It allows rings of Ethernet switches to overcome any single failure with recovery time much faster than achievable with Spanning Tree Protocol.
- **IP-based Bandwidth Management** : The switch provide advanced IP-based bandwidth management which can limit the maximum bandwidth for each IP device. User can configure IP camera and NVR with more bandwidth and limit other device bandwidth.
- **Application-Based QoS** : The switch also support application-based QoS. Application-based QoS can set highest priority for data stream according to TCP/UDP port number.
- **Device Binding Function** : ORing special Device Binding function can only permit allowed IP address with MAC address to access the network. Hacker cannot access the IP surveillance network without permission. It can avoid hacker from stealing video privacy data and attacking IP camera, NVR and controllers.
- **Advanced DOS/DDOS Auto Prevention** : The switch also provided advanced DOS/DDOS auto prevention. If there is any IP flow become big in short time, the switch will lock the source IP address for certain time to prevent the attack. It's hardware based prevention so it can prevent DOS/DDOS attack immediately and completely.
- **IEEE 1588 Technology** : The IEEE 1588 technology can fulfill precision time synchronization requirements for protection and control applications.
- **Modbus TCP** : This is a Modbus variant used for communications over TCP/IP networks.
- **IEEE 802.3az Energy-Efficient Ethernet** : This is a set of enhancements to the twisted-pair and backplane Ethernet family of networking standards that will allow for less power consumption during periods of low data activity. The intention was to reduce power consumption by 50% or more.

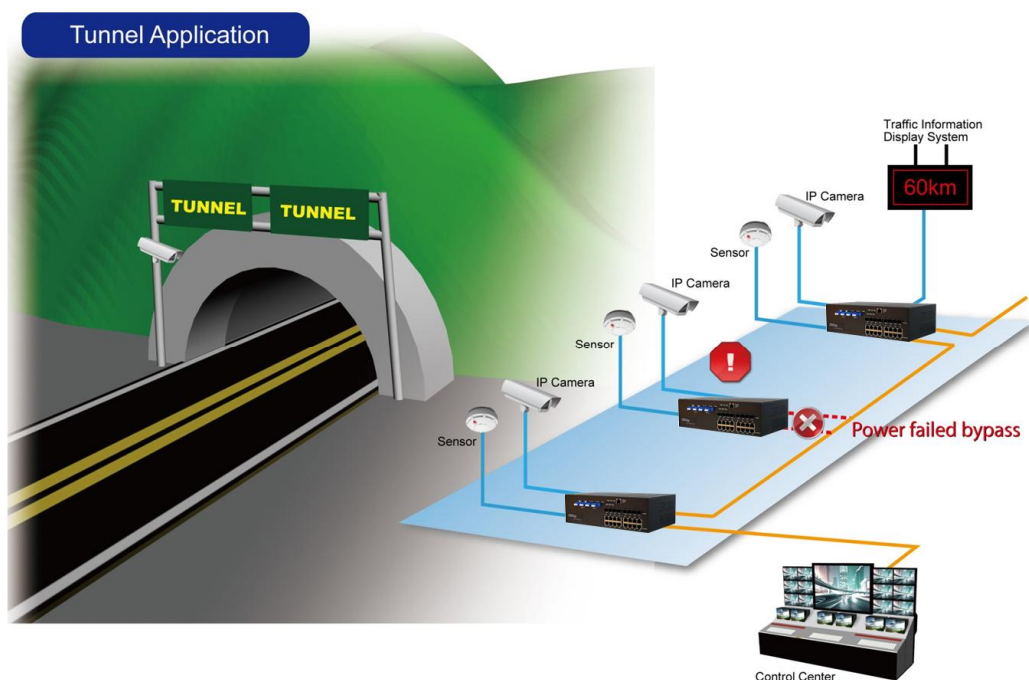

Open-Vision

Open-Vision is a consummate Management Windows Utility with advanced technology and friendly, client- oriented interface. The end users can easily configure and set all of the managed switches in a local network simultaneously within one single step. The end users could be benefited from the powerful managed switch.

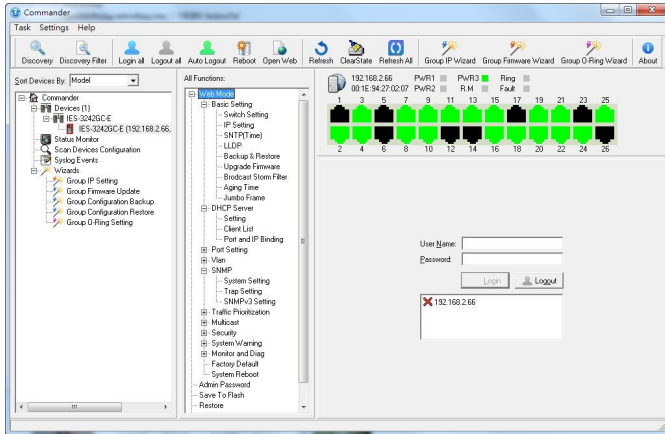

Commander

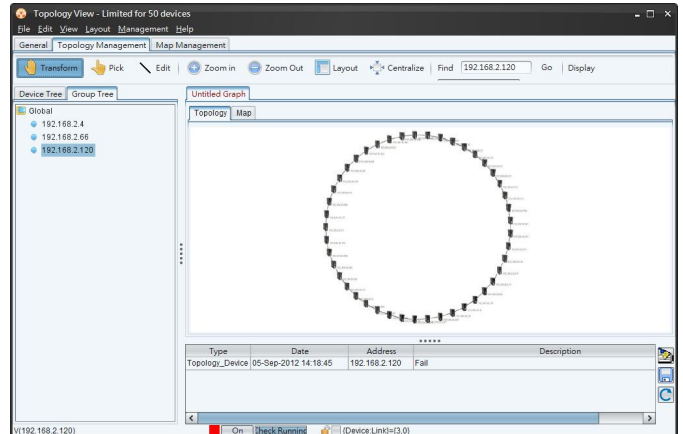

Topology View

Powerful Wizards:

◆ Group IP setting

After initial installation, IP address of all devices is default IP address. Group IP address can set increased IP address in certain range to all devices in a short time.

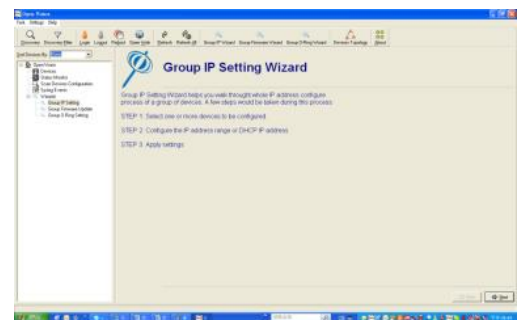

◆ Group firmware upgrade

Wizard can upgrade new firmware to all devices selected by several simple steps.

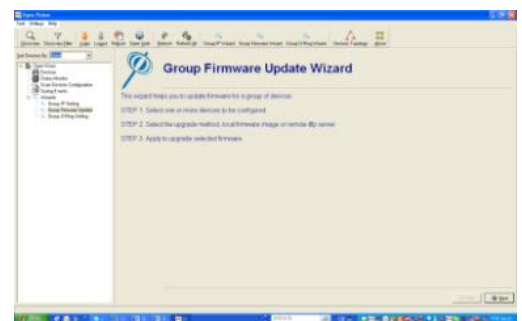

◆ Group redundant ring setting

Redundant ring is the most popular setting in the redundant switch. Wizard can configure redundant ring of all switches in several simple steps.

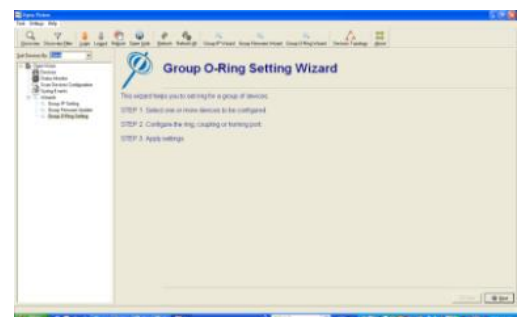

Bypass Technology

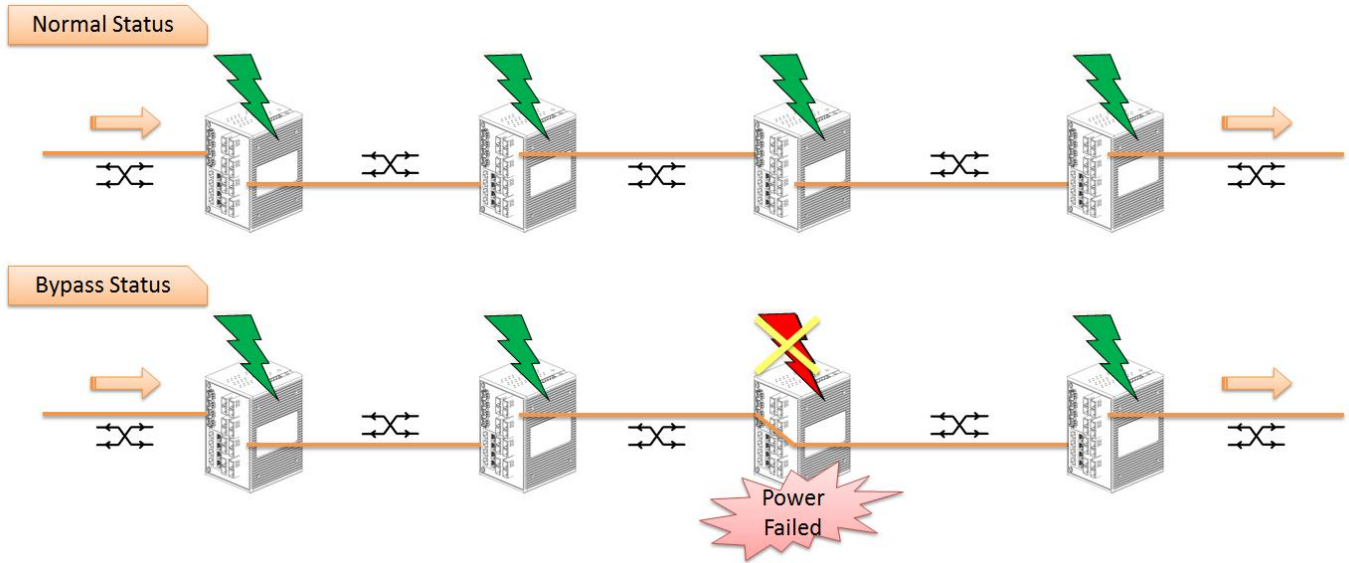

Dimension

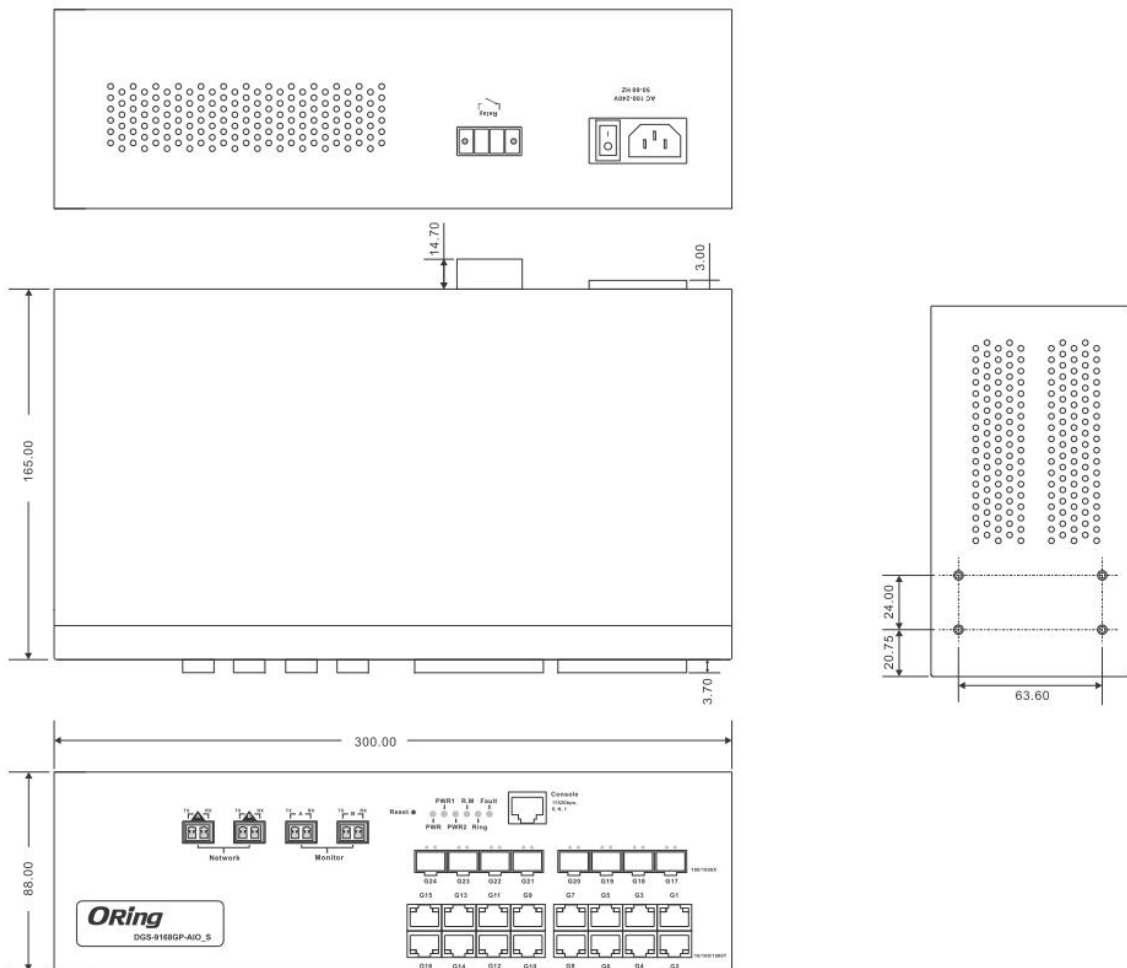

Specifications

| ORing Switch Model | DGS-9168GP-SS-AIO_S | DGS-9168GP-MM-AIO_S |
|--|--|---------------------|
| Physical Ports | | |
| 10/100/1000Base-T(X) Ports in RJ45 Auto MDI/MDIX | 16 | |
| 100/1000Base-X with SFP port | 8 | |
| LC Bypass Port Type | Single-Mode | Multi-Mode |
| Technology | | |
| Ethernet Standards | IEEE 802.3 for 10Base-T IEEE 802.3u for 100Base-TX and 100Base-FX IEEE 802.3ab for 1000Base-T IEEE 802.z for 1000Base-X IEEE 802.3x for Flow control IEEE 802.3ad for LACP (Link Aggregation Control Protocol) IEEE 802.1p for COS (Class of Service) IEEE 802.1Q for VLAN Tagging IEEE 802.1w for RSTP (Rapid Spanning Tree Protocol) IEEE 802.1s for MSTP (Multiple Spanning Tree Protocol) IEEE 802.1x for Authentication IEEE 802.1AB for LLDP (Link Layer Discovery Protocol) | |
| MAC Table | 8k | |
| Priority Queues | 8 | |
| Processing | Store-and-Forward | |
| Buffer Size | 4Mbit | |
| Jumbo Frame | 9.6K Bytes | |
| Switch Properties | Switching latency: 7 us Switching bandwidth: 48Gbps Max. Number of Available VLANs: 256 IGMP multicast groups: 128 for each VLAN Port rate limiting: User Define Https / SSH enhance network security | |
| Security Features | Device Binding security feature Enable/disable ports, MAC based port security Port based network access control (802.1x) VLAN (802.1Q) to segregate and secure network traffic Radius centralized password management SNMPv3 encrypted authentication and access security Https / SSH enhance network security | |
| Software Features | STP/RSTP/MSTP (IEEE 802.1D/w/s) Redundant Ring (O-Ring) with recovery time less than 30ms over 250 units TOS/Diffserv supported Quality of Service (802.1p) for real-time traffic VLAN (802.1Q) with VLAN tagging and GVRP supported IGMP Snooping IP-based bandwidth management Application-based OoS management DOS/DDOS auto prevention Port configuration, status, statistics, monitoring, security DHCP Server/Client/Relay SMTP Client Modbus TCP | |
| Network Redundancy | O-Ring Open-Ring O-Chain MRP Fast Recovery MSTP (RSTP/STP compatible) | |
| RS-232 Serial Console Port | RS-232 in RJ45 connector with console cable. 115200bps, 8, N, 1 | |
| Switch LED Indicators | | |
| Power Indicator (PWR/1/2) | Green : power LED x 3 | |
| R.M. indicator (R.M.) | Green : indicate system operated in O-Ring Master mode | |

| | |
|--|---|
| Ring indicator (Ring) | Green : indicate system operated in O-Ring mode |
| Fault indicator (Fault) | Amber : Indicate unexpected event occurred |
| 10/100/1000Base-T(X) RJ45 port indicator | Green for port Link/Act. Dual color LED for speed indicator : Green for 1000Mbps, Amber for 100Mbps, Off-light for 10Mbps |
| SFP Fiber port indicator | Green for port Link/Act. |
| Fault contact | |
| Relay | Relay output to carry capacity of 1A at 24VDC |
| Power | |
| Redundant Input power | Dual 100~240V AC power inputs in single power socket |
| Power consumption (Typ.) | 25 Watts |
| Overload current protection | Present |
| Physical Characteristic | |
| Enclosure | IP-30 |
| Dimension (W x D x H) | 300 (W) x 165 (D) x 88 (H) mm (11.81 x 6.5 x 3.47 inch) |
| Weight (g) | 2326 g |
| Environmental | |
| Storage Temperature | -40 to 85°C (-40 to 185°F) |
| Operating Temperature | -40 to 70°C (-40 to 158°F) |
| Operating Humidity | 5% to 95% Non-condensing |
| Regulatory approvals | |
| EMI | FCC Part 15, CISPR (EN55022) class A |
| EMS | EN61000-4-2 (ESD) EN61000-4-3 (RS), EN61000-4-4 (EFT), EN61000-4-5 (Surge), EN61000-4-6 (CS), EN61000-4-8, EN61000-4-11 |
| Shock | IEC60068-2-27 |
| Free Fall | IEC60068-2-32 |
| Vibration | IEC60068-2-6 |
| Safety | EN60950-1 |
| Warranty | 5 years |

Ordering Information

DGS-9AABCC-DD-AIO_S

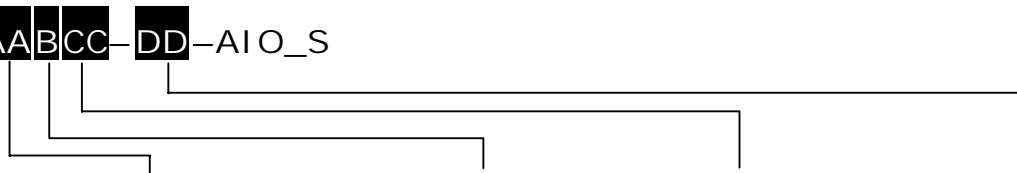

| Code | 10/100/1000Base-T(X) Port Number | 100/1000Base-(F)X SFP SFP Port Number | Additional Port Type | Fiber Optical Mode |
|--------|----------------------------------|---------------------------------------|------------------------|---------------------------------------|
| Option | - 16: 16 ports | - 8: 8 ports | -GP: Gigabit SFP ports | - MM: Multi-mode - SS: Single-mode |

| Available Model | Model Name | Description |
|-----------------|------------------------|---|
| | DGS-9168GP-SS-AIO_S_US | Industrial desktop type 24-port managed Gigabit Ethernet switch with 16x10/100/1000Base-T(X) and 8x100/1000Base-X, SFP socket, single-mode LC |

| | |
|-------------------------------|---|
| | connector bypass, US power cord |
| DGS-9168GP-SS-AIO_S_EU | Industrial desktop type 24-port managed Gigabit Ethernet switch with 16x10/100/1000Base-T(X) and 8x100/1000Base-X, SFP socket, single-mode LC connector bypass, EU power cord |
| DGS-9168GP-SS-AIO_S_UK | Industrial desktop type 24-port managed Gigabit Ethernet switch with 16x10/100/1000Base-T(X) and 8x100/1000Base-X, SFP socket, single-mode LC connector bypass, UK power cord |
| DGS-9168GP-SS-AIO_S_JP | Industrial desktop type 24-port managed Gigabit Ethernet switch with 16x10/100/1000Base-T(X) and 8x100/1000Base-X, SFP socket, single-mode LC connector bypass, JP power cord |
| DGS-9168GP-MM-AIO_S_US | Industrial desktop type 24-port managed Gigabit Ethernet switch with 16x10/100/1000Base-T(X) and 8x100/1000Base-X, SFP socket, multi-mode LC connector bypass, US power cord |
| DGS-9168GP-MM-AIO_S_EU | Industrial desktop type 24-port managed Gigabit Ethernet switch with 16x10/100/1000Base-T(X) and 8x100/1000Base-X, SFP socket, multi-mode LC connector bypass, EU power cord |
| DGS-9168GP-MM-AIO_S_UK | Industrial desktop type 24-port managed Gigabit Ethernet switch with 16x10/100/1000Base-T(X) and 8x100/1000Base-X, SFP socket, multi-mode LC connector bypass, UK power cord |
| DGS-9168GP-MM-AIO_S_JP | Industrial desktop type 24-port managed Gigabit Ethernet switch with 16x10/100/1000Base-T(X) and 8x100/1000Base-X, SFP socket, multi-mode LC connector bypass, JP power cord |

Packing List

- DGS-9168GP-AIO_S x 1
- Console Cable x 1
- ORing Tool CD x 1
- Power Cable x 1
- Quick Installation Guide x 1

Optional Accessories

- Open-Vision M500 : Powerful Network Management Windows Utility Suit, 500 IP devices
- SFP 1G series : 1Gbps SFP optical transceiver
- SFP 100 series : 100Mbps SFP optical transceiver