

# IES-1080/1062 Series

## ► Industrial 8-port unmanaged Ethernet switch

### Features

- IES-1080 provide 8x10/100Base-T(X) ports
- IES-1062GT provide 6x10/100Base-T(X) and 2x10/100/1000Base-T(X) ports
- IES-1062FX series provide 6x10/100Base-T(X) and 2x100Base-FX fiber ports
- IES-1062GF series provide 6x10/100Base-T(X) and 2x1000Base-X fiber ports
- Triple redundant DC power inputs of terminal block and power jack
- Support auto-negotiation and auto-MDI/MDI-X
- Support store and forward transmission
- Support flow control
- Warning system by relay output
- Rigid IP-30 housing design
- DIN-Rail and wall mounting enabled



### Introduction

IES-1080/1062 series are unmanaged Ethernet switches with 6x10/100Base-T(X) and 2x100Base-FX, 10/100/1000Base-T(X), 1000Base-SX or 1000Base-LX ports. IES-1080/1062 series support redundant power input, relay output alarm, and surge protection. The wide operating temperature range from -40°C to 70°C can satisfy most of operating environments.

### Practical Operation

IES-1080/1062 series can be used in connecting several Ethernet devices like Ethernet I/O, IP-Camera or other Ethernet switches. In addition, there are three different power inputs to enhance its reliability, two supplied by terminal block, and one by power jack to avoid interruption caused by power down. When the primary DC power input fails, the backup power input will take over immediately to guarantee a non-stop operation.



Connections of Ethernet devices

## Dimensions

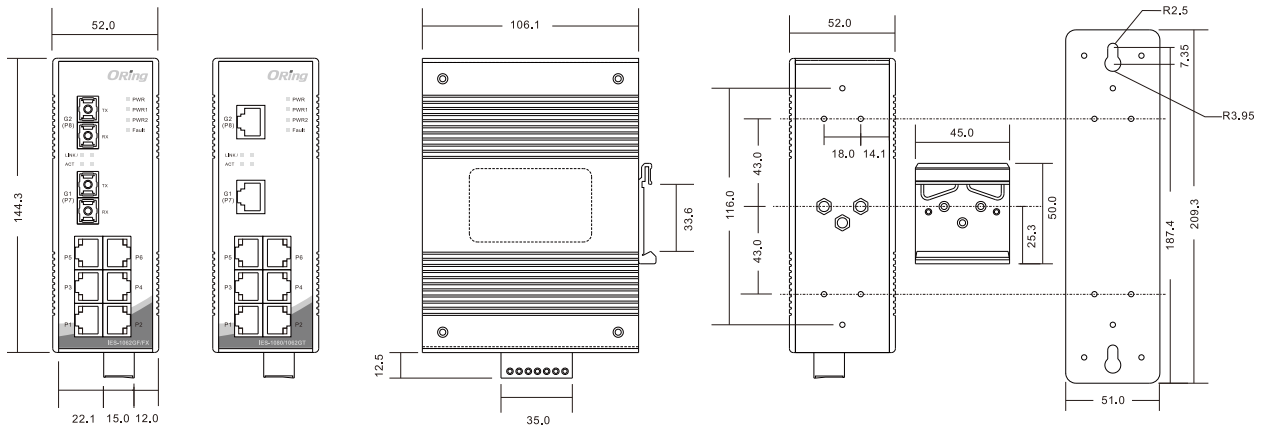

(Unit=mm)

## Specifications

ORing Switch Model		IES-1080	IES-1062GT	IES-1062FX-MM-SC	IES-1062FX-SS-SC	IES-1062GF-MM-SC	IES-1062GF-SS-SC
<b>Physical Ports</b>							
10/100Base-T(X) Ports in RJ45 Auto MDI/MDIX		8	6	6	6	6	6
10/100/1000Base-T(X) Ports in RJ45 Auto MDI/MDIX		-	2	-	-	-	-
Fiber Ports Specifications	Fiber Ports Number	-	-	2	2	2	2
	Fiber Ports Standard	-	-	100Base-FX	100Base-FX	1000Base-SX	1000Base-LX
	Fiber Mode	-	-	Multi-mode	Single-mode	Multi-mode	Single-mode
	Fiber Diameter (µm)	-	-	62.5/125 µm 50/125 µm	9/125 µm	62.5/125 µm 50/125 µm	9/125 µm
	Fiber Optical Connector	-	-	SC	SC	SC	SC
	Typical Distance (km)	-	-	2 km	30 km	0.55 km	10 km
	Wavelength (nm)	-	-	1310 nm	1310 nm	850 nm	1310 nm
	Max. Output Optical Power (dBm)	-	-	-14 dBm	-8 dBm	-4 dBm	-3 dBm
	Min. Output Optical Power (dBm)	-	-	-23.5 dBm	-15 dBm	-9.5 dBm	-9.5 dBm
	Max. Input Optical Power (Saturation)	-	-	0 dBm	0 dBm	0 dBm	-3 dBm
	Min. Input Optical Power (Sensitivity)	-	-	-31 dBm	-34 dBm	-18 dBm	-20 dBm
Link Budget (dB)	-	-	7.5 ab	19 dB	8.5 dB	10.5 dB	
<b>Technology</b>							

Ethernet Standards	IEEE 802.3 for 10Base-T IEEE 802.3u for 100Base-TX and 100Base-FX IEEE 802.3ab for 1000Base-T IEEE 802.3z for 1000Base-X IEEE 802.3x for Flow control					
MAC Table	8192 MAC addresses					
Processing	Store-and-Forward					
<b>LED Indicators</b>						
Power Indicator	Green : Power LED x 3					
Fault Indicator	Amber : Indicates PWR1 or PWR2 failure occurred					
10/100Base-FX RJ45 Port Indicator	Green for port Link/Act. Amber for Duplex/Collision					
10/100/1000Base-T(X) / Fiber Port Indicator	Green for port Link/Act. Amber for Link					
<b>Fault contact</b>						
Relay	Relay output to carry capacity of 1A at 24VDC					
<b>Power</b>						
Redundant Input Power	Triple DC inputs. 12~48VDC on 7-pin terminal block, 12~45VDC on power jack					
Power Consumption (Typ.)	4 Watts	7 Watts	8 Watts	8 Watts	6 Watts	6 Watts
Overload Current Protection	Present					
Reverse Polarity Protection	Present on terminal block					
<b>Physical Characteristics</b>						
Enclosure	IP-30					
Dimensions (W x D x H)	52(W) x 106.1(D) x 144.3(H) mm (2.05x4.18x5.68 inch.)					
Weight (g)	666 g	677 g	680 g	680 g	685 g	685 g
<b>Environmental</b>						
Storage Temperature	-40 to 85°C (-40 to 185°F)					
Operating Temperature	-40 to 70°C (-40 to 158°F)					
Operating Humidity	5% to 95% Non-condensing					
<b>Regulatory Approvals</b>						
EMI	FCC Part 15, CISPR (EN55022) class A					
EMS	EN61000-4-2 (ESD), EN61000-4-3 (RS), EN61000-4-4 (EFT), EN61000-4-5 (Surge), EN61000-4-6 (CS), EN61000-4-8, EN61000-4-11					
Shock	IEC60068-2-27					
Free Fall	IEC60068-2-32					
Vibration	IEC60068-2-6					
Safety	EN60950-1, UL508(E331061)					
MTBF (Hours) (MIL-HDBK-217F2, GB, GC, 25°C)	431,222	368,351	322,144	323,065	335,245	336,243
Warranty	5 years					

- Company Information
- 2011 Product Overview
- Vertical Market Applications
- Industrial Ethernet Switch**
- Industrial Media Converter
- Industrial Device Server
- Industrial Wireless Access Point
- Industrial Cellular VPN Router
- Industrial USB-Over-IP Server
- Accessories
- Network Management Utility

## Ordering Information

IES-1 **AA** **B** **CC** - **DD** - **EE**

Code Definition	10/100Base-T(X) Port Number	Additional Port Number	Additional Port Type	Fiber Optical Mode	Fiber Optical Connector
<b>Option</b>	- <b>08</b> : 8 ports - <b>06</b> : 6 ports	- <b>0</b> : 0 port - <b>2</b> : 2 ports	- <b>GT</b> : 10/100/1000Base-T(X) - <b>FX</b> : 100Base-FX - <b>GF</b> : 1000Base-X	- <b>MM</b> : Multi-mode - <b>SS</b> : Single-mode	- <b>SC</b> : SC connector

	Model Name	Description
Available Model	IES-1080	Industrial 8-port unmanaged Ethernet switch with 8x10/100Base-T(X)
	IES-1062GT	Industrial 8-port unmanaged Ethernet switch with 6x10/100Base-T(X) and 2x10/100/1000Base-T(X)
	IES-1062FX-MM-SC	Industrial 8-port unmanaged Ethernet switch with 6x10/100Base-T(X) and 2x100Base-FX, multi-mode, 2km/1310nm, SC connector
	IES-1062FX-SS-SC	Industrial 8-port unmanaged Ethernet switch with 6x10/100Base-T(X) and 2x100Base-FX, single-mode, 30km/1310nm, SC connector
	IES-1062GF-MM-SC	Industrial 8-port unmanaged Ethernet switch with 6x10/100Base-T(X) and 2x1000Base-SX, multi-mode, 550m/850nm, SC connector
	IES-1062GF-SS-SC	Industrial 8-port unmanaged Ethernet switch with 6x10/100Base-T(X) and 2x1000Base-LX, single-mode, 10km/1310nm, SC connector
<b>Packing List</b>		<b>Optional Accessories</b>
<ul style="list-style-type: none"> <li>IES-1080 / 1062 series</li> <li>DIN-Rail Kit</li> <li>Wall-mount Kit</li> <li>Quick Installation Guide</li> </ul>		<ul style="list-style-type: none"> <li>DR-45 series, 45W DIN-Rail power supply</li> <li>DR-75 series, 75W DIN-Rail power supply</li> <li>DR-120 series, 120W DIN-Rail power supply</li> <li>PAA-121000, 12VDC/1000mA 12W Power Adapter with universal 100 to 240VAC input, US plug</li> <li>PAE-121000, 12VDC/1000mA 12W Power Adapter with universal 100 to 240VAC input, EU plug</li> </ul>