

**Power Xpert™ UX**  
IEC Medium Voltage switchgear

- Tested to IEC 62271-200  
17.5 kV up to 50 kA - 3 s  
24 kV up to 25 kA - 3 s

- Air insulated switchgear
- Internal arc classified
- LSC2B-PM

# UX

## Safe, reliable MV switchgear



# Energizing a world that demands more.

Discover today's Eaton.

## Powering business worldwide

As a global diversified power management company, we help customers worldwide manage the power needed for buildings, aircraft, trucks, cars, machinery and businesses.

Eaton's innovative technologies help customers manage electrical, hydraulic and mechanical power more reliably, efficiently, safely and sustainably.



# MV switchgear technology is in our DNA

Eaton Corporation is a worldwide leader in the design, manufacture, and sale of safe, reliable and high-performance medium voltage power distribution equipment in accordance with IEC, GB and ANSI standards.

## Complete Global Medium Voltage Switchgear Solutions

Eaton, a premier leader in designing and manufacturing power distribution and protection equipment in the electrical industry, offers a comprehensive range of medium voltage (MV) solutions to meet the needs of virtually every application. From products that feature cutting-edge design that allow for easy access, maintenance and space savings, to arc-resistant products that enhance safety, Eaton's medium voltage solutions provide a variety of products for every need. Additionally, Eaton's global service network provides maximum customer support in all regions of the world.

As one of the few completely vertically integrated and diversified industrial manufacturers in the world, Eaton designs not only MV assemblies, but also the key components that comprise the MV solutions – from steel housing and circuit breaker compartments to vacuum interrupters, circuit breakers, bus systems and fuses.

Eaton's MV heritage, strengthened by acquisitions such as Westinghouse DCBU, Cutler Hammer, MEM and Holec, has resulted in breakthrough MV technologies and numerous international patents over the years.

Part of Eaton's complete electrical PowerChain Solutions – which help businesses minimize risks while realizing greater reliability, cost efficiencies, capital utilization and safety – Eaton's medium voltage equipment meets all applicable standards and certifications such as IEC, NEMA / ANSI, GB, UL, IEEE, KEMA and CSA.

When it comes to medium voltage solutions, you can trust the one name with a long history of proven performance: Eaton.



## Safe, reliable MV switchgear with sustainability built-in



Innovative in its design, originated from the Unitle family, field-proven over forty years of vacuum circuit breaker production and fully third-party certified to IEC 62271-100 and IEC 62271-200, Eaton's new UX range of compact air insulated withdrawable Medium Voltage switchgear leads the industry in safety, reliability, performance and sustainability.

### Knowledge and understanding

Eaton has over 80 years experience in the design, manufacture and application of Medium Voltage switchgear. Being at the forefront of technological advances, we pioneered the use of vacuum technology 80 years ago and introduced epoxy-resin insulation over 50 years ago. Eaton is still committed to developing, innovating and improving - as well as to reducing size and costs.

Millions of our vacuum interrupters have been in operation in every type of environment in the world, catering for the widest range of applications. It is this knowledge, understanding and experience that make Eaton the logical choice for the safe control and protection of distribution systems.

UX is particularly suited to provide control and protection for cables, transformers, capacitors and motors used across many industries. In fact UX excels anywhere that medium voltage power has to be switched, controlled and protected.

### Built to the highest quality standards

UX is designed and fully third-party type-tested to the latest IEC 62271-200 standards, with full segregation by earthed metal partitions of all the major compartments, and is equipped with Eaton's very latest range of IEC vacuum circuit breakers type W-VAC/ - which are fully third-party type-tested in accordance with IEC 62271-100.

Using Eaton's state of the art technology and manufactured in accordance with the highest quality standards, our engineers have integrated core technologies, such as circuit breaker and mechanism design, vacuum technology, solid insulation and electrical field control to build a reliable and compact system, which benefit from the best practices incorporated in our current medium voltage range.

## A complete range of compact, environmentally-friendly switchgear up to 4000 A

The system, which comprises a complete range up to 4000 A, uses only environmentally friendly technology and materials. UX is based on vacuum technology and air insulation, and is therefore the perfect alternative to

environmentally harmful SF<sub>6</sub> gas insulated switchgear. It is also produced with fully recyclable materials ensuring that at the end of its life the product can be safely and efficiently recycled - providing a wholly sustainable solution

to medium voltage switchgear applications.

Some applications are:

- Power distribution
- Water and waste water treatment

- Mining
- Commercial buildings
- Industrial facilities
- Oil and gas (on- and off-shore)
- Marine
- Airports and hospitals.



# World leading technology with safety built in

Combining advanced technology with proven engineering excellence, the UX range provides the highest safety and reliability standards without compromising competitiveness.

As pioneers in vacuum and arc-interruption technologies, further developed over 40 years, Eaton has millions of vacuum interrupters successfully operating in multiple applications worldwide; Eaton's latest vacuum circuit breaker, the W-VACi, sits at the heart of UX.

## Minimal costs during service due to:

- Robust maintenance-free design with minimum number of parts
- W-VACi circuit breaker has a long life of 20,000 operations without the need for active maintenance.
- Advanced vacuum interrupter contact designs prevent hot spots, create less heat and minimise electrode erosion to yield longer life.
- No SF<sub>6</sub> pressure checks and specialised refilling procedures

Low end of life disposal costs due to:

- Vacuum switching technology
- Air insulation
- Recycling or re-use of all materials possible
- No special decommissioning procedures necessary

## User friendly

- Cable connection and user interfaces for operation on the same side of the unit
- Multiple cables per phase with standard compression lug for ease of cable connection
- Secondary cable entry points on both sides of the low voltage compartment top plate
- Secondary cable wire way runs complete over the length of the switchgear to help with inter-unit wiring.
- Secondary cable terminals positioned at a good reachable height within the low voltage compartment
- Clear and simple, straightforward operation panels combined with an active mimic diagram

## Low environmental impact

Increasing global legislation concerning the use of greenhouse gases such as SF<sub>6</sub> gas and their related disposal costs, makes vacuum technology with its reliability, low maintenance, and low environmental impact the choice for now and the future.

As the world strives to reduce the amount of SF<sub>6</sub> gas used in all applications there is a responsibility on the users of electrical switchgear to find, where appropriate, alternatives to SF<sub>6</sub> gas as an insulation and switching medium. Air and solid insulation switchgear systems incorporating vacuum switching technologies are a reliable, safe and economic alternative for use in electrical systems below 36 kV and therefore should be used instead of SF<sub>6</sub> gas insulated systems.

Modern medium voltage switchgear employing vacuum technology together with air and epoxy resin insulation provides:

- Minimum number of parts and components
- No special requirements for the end-of-life disposal of the switchgear
- Environmentally-friendly materials used in the design
- No use of SF<sub>6</sub>-gas for switching and insulation (green switching)
- No risk of damaging leaks of SF<sub>6</sub> gas or of toxic by-products
- Energy-efficient production and assembly, with environmentally friendly energy sources
- Minimal number of transition points in the primary design enables low energy loss during operation
- Only re-usable and/or recyclable materials used

## Fully type-tested to latest IEC standards

The switchgear is type tested to the latest IEC 62271-200 and has third-party certification to prove internal arc containment classification of AFLR from 25 kA up to 50 kA for one second. This means there is minimal risk of harm to

personnel in the unlikely event of an internal arc in the cable compartment, vacuum circuit breaker compartment or the busbar compartment in any direction: front, rear and sides of the switchgear.



## Safety, reliability and performance

- Compartments are protected against penetration by objects
- Internal arc classification of AFLR provides operator safety in the unlikely event of an internal arc
- Operation only possible with the circuit breaker compartment door closed
- Logical mechanical and electrical interlocks prevent mal-operation
- Capacitive voltage detection system for verification of safe isolation from supply
- In the unlikely event of vacuum interrupter failure there is no damage to personnel and no harmful gases are emitted.
- Vacuum interrupter contact erosion is negligible
- Fully encapsulated vacuum interrupters
- Fewer moving parts in the pole unit versus other arc interruption technologies

## Reliable and safe in operation

- Complete design third party certified in accordance with IEC 62271-200
- Internal arc fault tested in accordance with IEC 62271-200
- Quality assurance in accordance with ISO 9001
- Separate compartments for; cable, vacuum circuit breaker and busbars
- Integrated arc chamber
- Routine tested

## Low lifetime cost

Low initial costs due to:

- Compact footprint
- Cable access from front or rear
- Cable entry from either top or bottom
- Easy-access cable compartment for ease of cable connection
- Integrated arc chamber
- Back to wall configuration with front cable access

# UX vacuum technology switchgear system

## Basic design

UX is modular in construction, ensuring that any panel combination and rating can be applied on a system.

In addition, there is no limit to the number of panels that can be used in an installation, as several sections can easily be connected together. Because the panels can be quickly assembled and connected, flexible commissioning of the switchgear is an added benefit.

### 1 Arc chamber

The integral arc-chamber evacuates the gasses associated with an internal arc. Optional standard parts are available to extend the arc chamber; flanges and grilles are available to exhaust the gasses outside the switchgear room.

### 2 Low voltage wire-way for inter panel wiring

A fully segregated metal wire-way is mounted at the top of each switchgear panel that connects together to form a continuous low voltage wire-way that runs along the entire length of the switchgear.

### 3 Low voltage compartment



The compartment is segregated with earthed metal partitions and has ample space for control and protection devices.

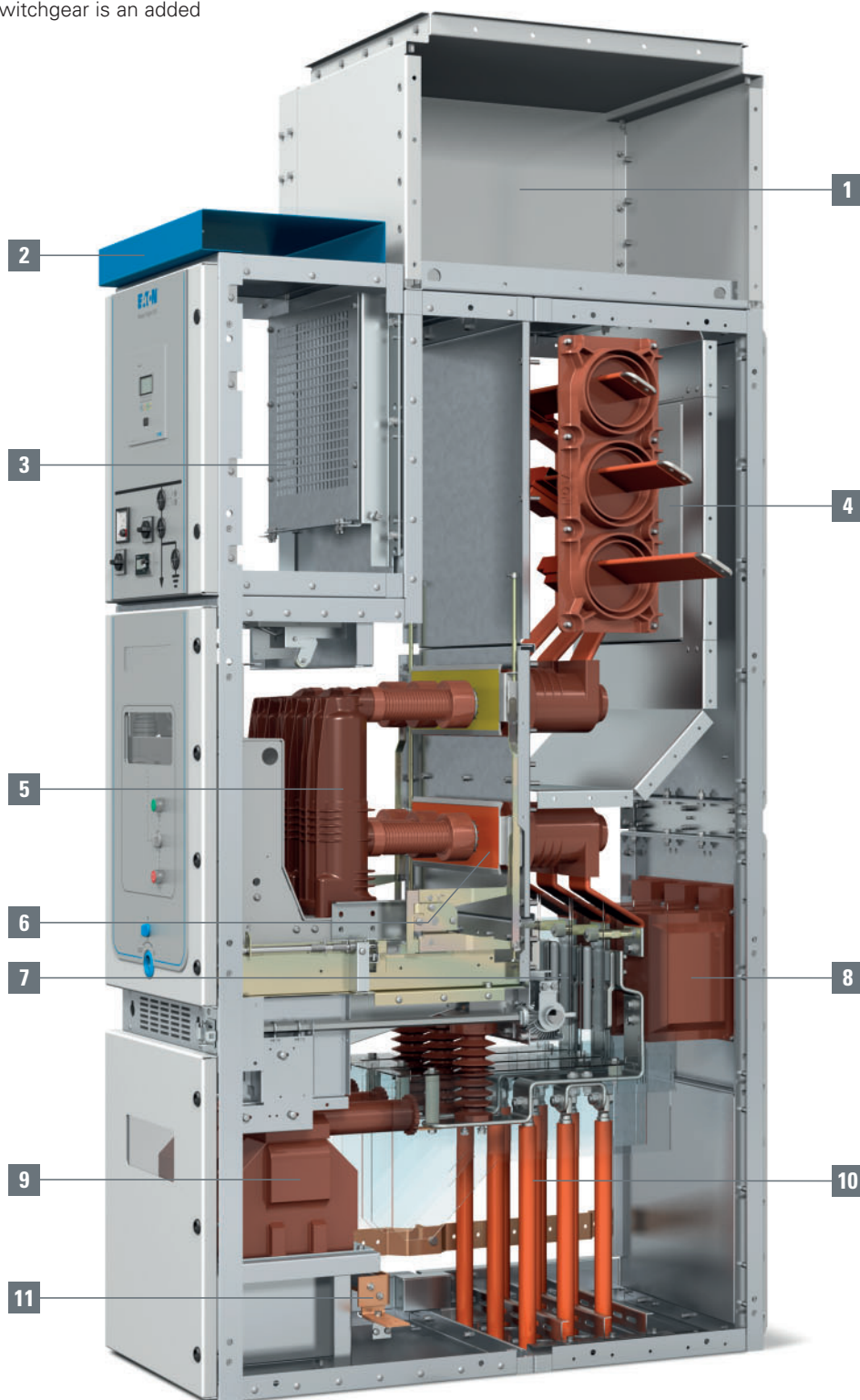

# superior safety, reliability and performance

## 4 Busbar compartment

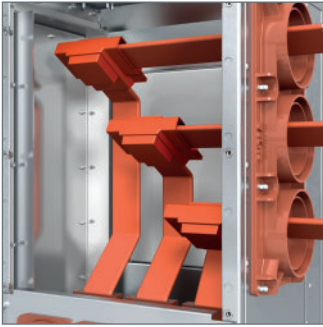

Busbars are totally enclosed in their own earthed metal compartment which vents into the arc chamber. Fully insulated along their entire length, the busbars are type tested for ratings up to 4000 A, 50 kA for 3 seconds. Epoxy mouldings segregate switchgear sections.

## 5 Vacuum circuit breaker compartment



Fully segregated by earthed metal partitions, with its own pressure relief channel into the arc chamber, the compartment provides all the safety interlocking mechanisms required for safe and reliable operation of the vacuum circuit breaker. Manual operation buttons allow for full operation of the vacuum circuit breaker from the front of the switchgear with the door fully closed. The circuit breaker is mechanically interlocked with the compartment door so that the door cannot be opened until the circuit breaker is switched Off and racked out into the Test position.

## 6 Automatic shutters



Individually operated automatic earthed metal shutters for both the Line (busbar) and Load (cable) connections can be padlocked in the closed position. When the breaker is in Test or Disconnect positions the shutters automatically close to prevent accidental contact with any live parts.

## 7 Circuit earth switch

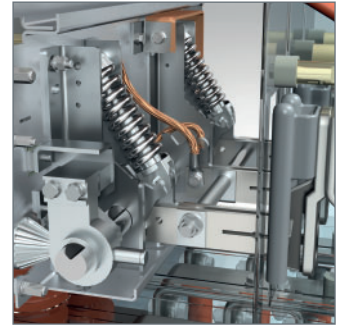

The earth switch is operated from the front of the switchgear, with mechanical indicators to show the switch position. A window allows direct viewing of the earth switch position. The earth switch is mechanically interlocked with the circuit breaker or contactor truck such that it can only be closed when truck is in the Test/Disconnect position. The circuit earth switch can be mechanically interlocked with the cable compartment door as an additional safety measure.



## 8 Current transformers

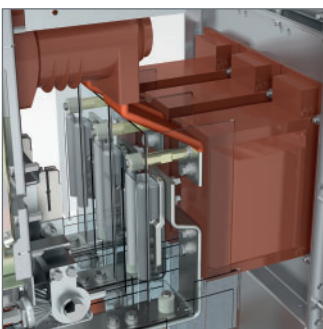

Cast resin CTs are provided as standard in a wide range of ratings, with an option to use low voltage tape-wound CTs in the same location.

## 9 Voltage transformers

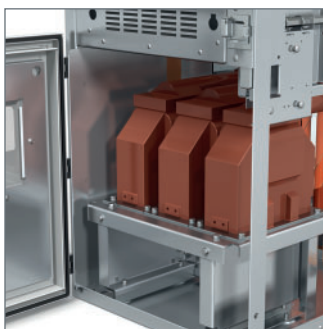

The voltage transformers are available in 3 configurations: Fixed, Withdrawable with shutters, and Withdrawable without shutters. All options are fitted with withdrawable primary fuses. The compartment door can be interlocked with the earth switch to ensure that the cables are safely earthed before the door is opened. The withdrawable option with shutters can be disconnected from the supply with the compartment door closed and with cables still live. The door can then be opened to remove the

## 10 Cable terminations

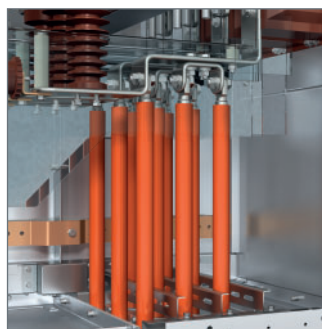

Ample cable termination provision is provided up to 9 single core cables per phase to enter the bottom of the switchgear and are terminated with compression lugs onto copper tails provided in the bottom of each panel.

## 11 Earth bar

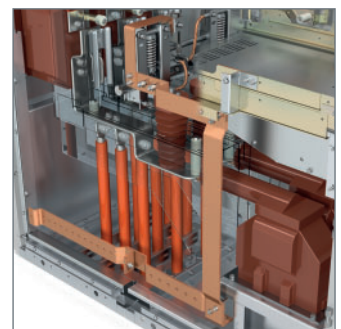

An earth bar system is provided making connections to the station earth easy and effective. The earth bar system has been fault tested and runs vertically and horizontally within each panel section and is connected to the earth switch, when provided.

# Control and protection

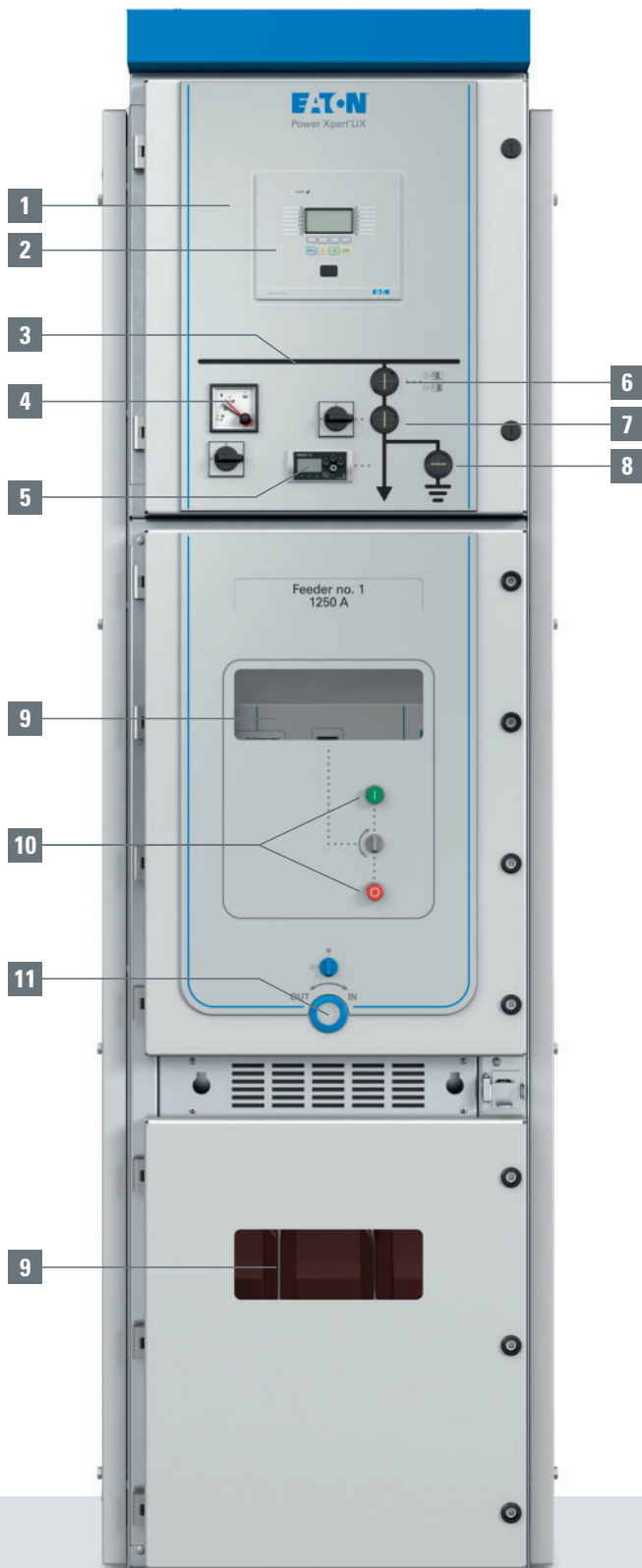

## 1 Low voltage control and protection compartment

Clear to view panel with all controls and indications clearly visible and easy to operate.

## 2 Protection relay

Eaton has a range of preferred relay options that can be fitted as standard. However, customer specific protection relays from any manufacturer can be fitted to the compartment door.

## 3 Mimic diagram

Easy to understand mimic diagram of each circuit.

## 4 Metering with phase selector switch

Option for an ammeter and phase selector switch.

Option for voltmeter and phase selector switch.

## 5 Voltage detection system

Each circuit breaker panel can be equipped with an optional standard three phase voltage detection system for voltage detection to IEC 61243-5. The VDS is driven from a capacitive divider fitted within the insulators connected to the cable connection and shows the operator if the connected cable is live.

## 6 Circuit breaker position indicator

Breaker position indication shows the breaker in the Connected/Service or Disconnected/Test position.

## 7 Electrical operation with circuit breaker status indicator

Breaker Open/Closed status indicator.

Breaker Open/Closed command switch.

Optional LED indication of spring charge mechanism "Charged" status

## 8 Earth switch indicator

Optional LED indication of earth switch Open/Closed status.

## 9 Viewing windows

The circuit breaker compartment door viewing window provides visual indication of the position of the circuit breaker indicating:

- The status of the breaker
- The status of the spring-charged mechanism

The cable compartment door viewing window allows visual indication of:

- The status of the earth switch
- Inspection of the cable connections

## 10 Manual circuit breaker operation

Circuit breaker Open and Close buttons

## 11 Circuit breaker racking mechanism

Circuit breaker racking In/Out mechanism

Clear distinct operator panel for user friendly operation



# Eaton core technologies

## Vacuum technology: safe, compact and reliable

Eaton's vacuum interrupters consist of a ceramic cylinder that houses fixed and movable contacts. Movement of the contact under vacuum conditions is performed by bellows. A shield surrounding the contacts prevents the insulators from becoming contaminated by any metal vapour produced during current interruption. This shield also ensures good voltage potential distribution over the insulator.

A special feature of Eaton's vacuum interrupters is the creation of a large number of parallel arcs between the contacts. This "diffuse discharge" is characterised by very low arc voltage and short

arc times, resulting in very low arc energy - so contact wear in a vacuum interrupter is negligible.

Vacuum interrupters are maintenance free and are certified up to 30,000 operation cycles.

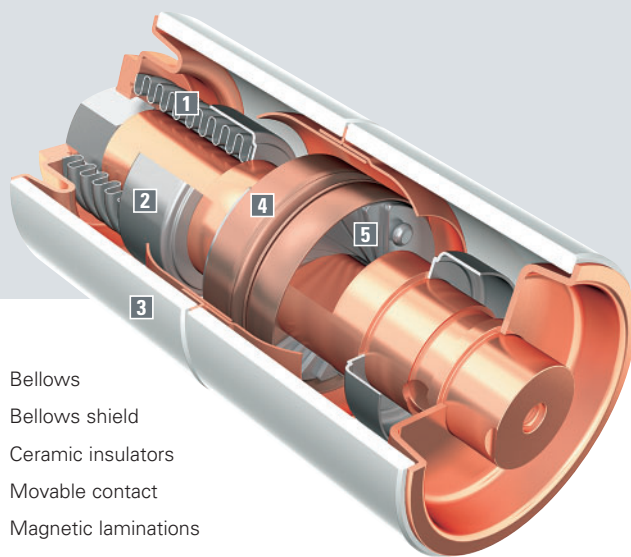
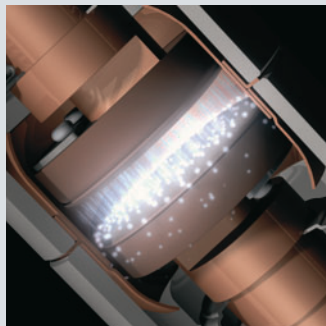

1. Bellows
2. Bellows shield
3. Ceramic insulators
4. Movable contact
5. Magnetic laminations

## Solid insulation using cast-resin technology

Cast-resin is a high-quality primary insulation material. By using cast-resin for solid insulation, Eaton's design engineers can shape the parts specifically for optimal insulation, robust construction and cooling purposes.

With over 50 years of experience in the design and manufacture of cast-resin components, Eaton has determined that the best solution is to embed the conductors and vacuum interrupters directly into the moulding to form a single encapsulated pole unit (EPU).

### Features

- High mechanical strength for improved durability and mechanical life of the pole unit
- Protected against adverse climatic conditions and humidity
- Protected against mechanical impact, shock and vibration
- Provides high thermal conductivity for improved temperature rating
- High electrical resistivity and creepage current resistance for improved insulation and compact design



# Main components

## Vacuum circuit breaker



The vacuum circuit breaker uses a simple and reliable, true two step spring charged mechanism for operation of the vacuum interrupters. The construction of the mechanical linkage between the actuator and the drive rod of each of the three vacuum interrupters is simple and effective.

### Features

- Environmentally friendly vacuum interrupters totally encapsulated within pole units constructed of solid epoxy resin
- Mechanically and electrically trip-free stored energy mechanism design
- Integrated mechanical lever for manual charging operation with pushbutton control
- Spring charged indicator with contacts for remote indication of spring status
- Mechanical status indicator for Open/Closed
- Auxiliary contacts for Open/Closed position
- Position indicator for Connected/Test position within the compartment
- Auxiliary contacts for remote position indication
- Mechanically interlocked with the compartment door
- Mechanical interlock to ensure the breaker is in the open position before it can be racked-in or racked-out

## Busbars

The busbar system is constructed from high-quality hard drawn copper bars of standardised cross-section.

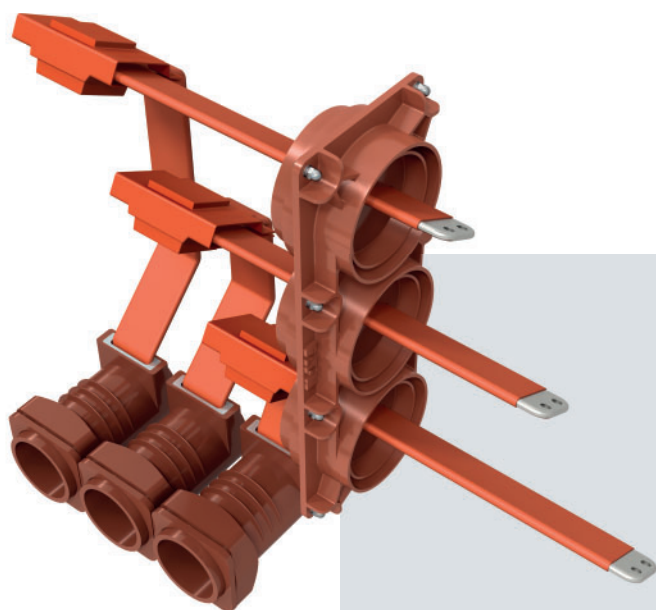

### Features

- Busbar compartment runs over the entire length of the switchboard
- Individual panel segregation between sections of the busbar chamber
- Constructed from high-quality hard-drawn copper of standard dimensions
- Fully insulated over the entire length of the switchboard
- Busbar chamber vents directly into the integral arc-chamber
- Busbar ratings up to 4000 A
- Busbar short circuit ratings up to 50 kA - 3 s



## Contactor

For motor starters, transformers and capacitor banks, the UX system is available with vacuum contactor trucks. Contactors for 3.6 or 7.2 kV can be mounted on a truck together with fuses, and voltage transformers. Surge arresters can also be mounted at the cable terminals. For motor control applications up to 7.2 kV, UX incorporates the Eaton range of SL contactors. For motor starters at 12 kV please contact Eaton.

### Features

- Environmentally friendly vacuum interrupters
- Ratings up to 400 amps at 6.6 kV
- Capacitor switching up to 295 amps at 6.6 kV
- Maximum interruption current of 8.5 kA
- Fuse protected up to 50 kA
- Electronic coil control for optimum control of the coil voltage and reduced watts loss means more efficient use of power and lower heat generation
- Electronic coil control allows for field selectable control voltages and drop out times
- Up to 6 auxiliary contacts in any combination of Normally Open and Normally Closed configurations
- Mechanical latch option is available with electrical unlatch signal.
- Long life with up to 1 million electrical operations and 2.5 million mechanical operations with no maintenance or adjustment required

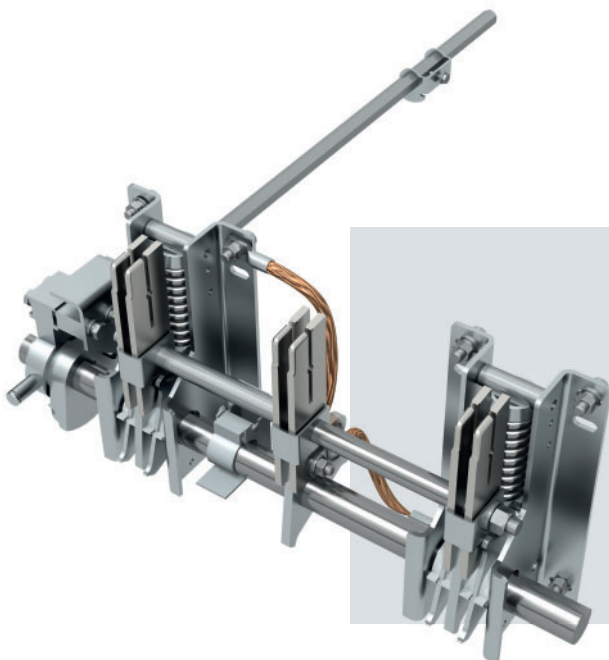

## Earth switch

All panels can be equipped with a cable earthing switch. The earth switch is mechanically interlocked with the circuit breaker so that the earth switch can only be operated when the circuit breaker is open, and withdrawn to the 'Disconnected/Test' position.

### Features

- Fully fault-rated earth switch
- Operated from the front of the panel
- Auxiliary contacts for service/earthed positions
- Mechanical position indicators
- Mechanically and/or electrically interlocked with the vacuum circuit breaker

# Safe and reliable in use

Proven experience and knowledge gained by Eaton over many years in the areas of cast-resin technology, vacuum technology, arc interruption and electrical field control have been integrated in the design and development of UX - ensuring that the switchgear is safe and has high operational reliability throughout its lifetime.



## Internal Arc Classification (IAC) of AFLR

While the integrity of the equipment to provide continuity of supply was a major design consideration throughout its development, the safety of the operator has also been one of the most important criteria, with a number of reassuring features built in.

All of Eaton's medium voltage systems, including UX, have been third party tested to all relevant standards, and are in accordance with IEC regulations.

Eaton has always emphasised the need to design and create safe switchgear for operators at all times.

One of the biggest potential threats to operators is an

internal arc in the switchgear. The metal-clad design and the robust construction has enabled UX to successfully pass internal arcing test in accordance with IEC 62271-200 in all three primary compartments and provides an IAC rating of 25 kA up to 50 kA for one second.

IEC62271-200 defines the level of protection to be provided in the event of an internal arc fault being generated within the switchgear. UX has been proven by independent third-party test to provide an IAC Classification of IAC = AFLR.

A = Protection for personnel  
F = Protection at the Front of the switchgear

L = Protection at the Lateral (sides) of the switchgear

R = Protection at the Rear of the switchgear

The IEC standard requires that an internal arc test is carried out in each of the power sections of the switchgear. In UX this means the cable compartment, the vacuum circuit breaker compartment, and the main busbar compartment.

The standard allows for each test to be conducted in individual switchgear panels - meaning that three separate panels can be used to prove the integrity of the design.

UX, however, has achieved IEC62271-200 with all three tests being conducted in the same panel. It is an important safety feature and indication of strength that UX passed all three required tests in the same panel.

The UX has the following IAC ratings:

**12 kV and 17.5 kV:**  
25 kA - 1 s, 26.3 kA - 1 s,  
31.5 kA - 1 s, 40 kA - 1 s and  
50 kA - 1 s

**24 kV:**  
25 kA - 1 s

## Loss of service continuity classification

IEC62271-200 describes the extent to which the switchgear and control gear are allowed to remain operational in case access to a main compartment is necessary.

UX has the highest attainable level of Loss of Service Continuity of LSC2B.

### Category LSC2B

This form allows for maximum continuity of service of the system during access to the compartments inside the switchgear - meaning that the main switching device of each functional unit of an LSC2B switchgear is fitted in its own accessible compartment. Maintenance may be performed on the main switching device without de-energizing the

corresponding cable connection or the main busbars. As a consequence, in this example of LSC2B switchgear, a minimum of 3 compartments for each functional unit is necessary:

- 1 for each main switching device
- 1 for components connected to one side of a main switching device, for example, feeder circuit
- 1 for components connected to the other side of the main switching device, for example, busbars

Switchgear is classified as LSC2B when it is possible and safe to open the circuit breaker compartment when the cable and busbars are energised.

## Partition classification

In addition to the IAC and the LSC classifications, IEC62271-200 defines the type of partitions required between each panel and between each functional unit within the panel.

UX employs only earthed metal partitions and therefore has the highest level of partition classification of PM.

UX switchgear is equipped with automatic earthed metal shutters. Individually operated shutters for both the Line

(busbar) and Load (cable) connections can be padlocked in the closed position. When the vacuum circuit breaker is in the test or the disconnect positions the shutters will automatically close to prevent accidental contact with any live parts. For testing purposes, special shutter lifters are used to maintain the shutters in the open position. Colour coded and labelled 'Busbar' and 'Cable', the shutters are easily identified as Open or Closed.



## Routine tests

In addition to the third party certified type testing programme to prove the integrity of the UX design, Eaton conducts routine tests on each vacuum interrupter, circuit breaker and switchgear panel. At a minimum these tests confirm compliance with the relevant IEC standards; however customer specific test procedures and witness of tests can be accommodated. To ensure quality, all processes are performed in accordance with ISO 9001 - at every stage of production the components, circuit breakers and current transformers are inspected for correct functioning. When the entire installation has been assembled, a thorough visual inspection is carried out, together with the required mechanical, functional and electrical checks.

## Accessibility of compartments

IEC62271-200 defines the accessibility classification for each of the power sections in the switchgear. UX has the following accessibility definitions.

- Busbar: tool-based/non-accessible
- Circuit breaker: interlocked controlled
- Cable: tool-based or option for interlocked controlled

## Ingress of foreign objects

UX has an external protection degree of IP4X as per IEC 60529 with an option of IP41 available. Internal ingress protection to IP2X is standard with an option for IP3X for more demanding applications. Separation eliminates the penetration of foreign objects and reduces the risk of accidental contact with any live parts.

## Safety interlocks

For personnel safety UX is designed with a number of comprehensive mechanical interlocks to prevent unsafe operation.

- It is not possible to rack-in or rack-out a circuit breaker unless it is in the Off or Open position.
- It is not possible to close a circuit breaker unless the circuit breaker is in the Connected or Test position.
- The secondary socket can only be disconnected with the circuit breaker in the test position.
- Closing the circuit breaker is only possible with the secondary contacts connected.
- It is not possible to close the earth switch when the circuit breaker is in the Connected position.
- The door of the vacuum circuit breaker compartment can only be opened when the circuit breaker is in the Disconnected / Test position.
- It is only possible to rack-in or rack-out the circuit breaker when the circuit breaker door is closed.
- The cable compartment door can only be opened when the earth switch is in the Closed position.
- The earth switch cannot be Opened when the cable compartment door is open.

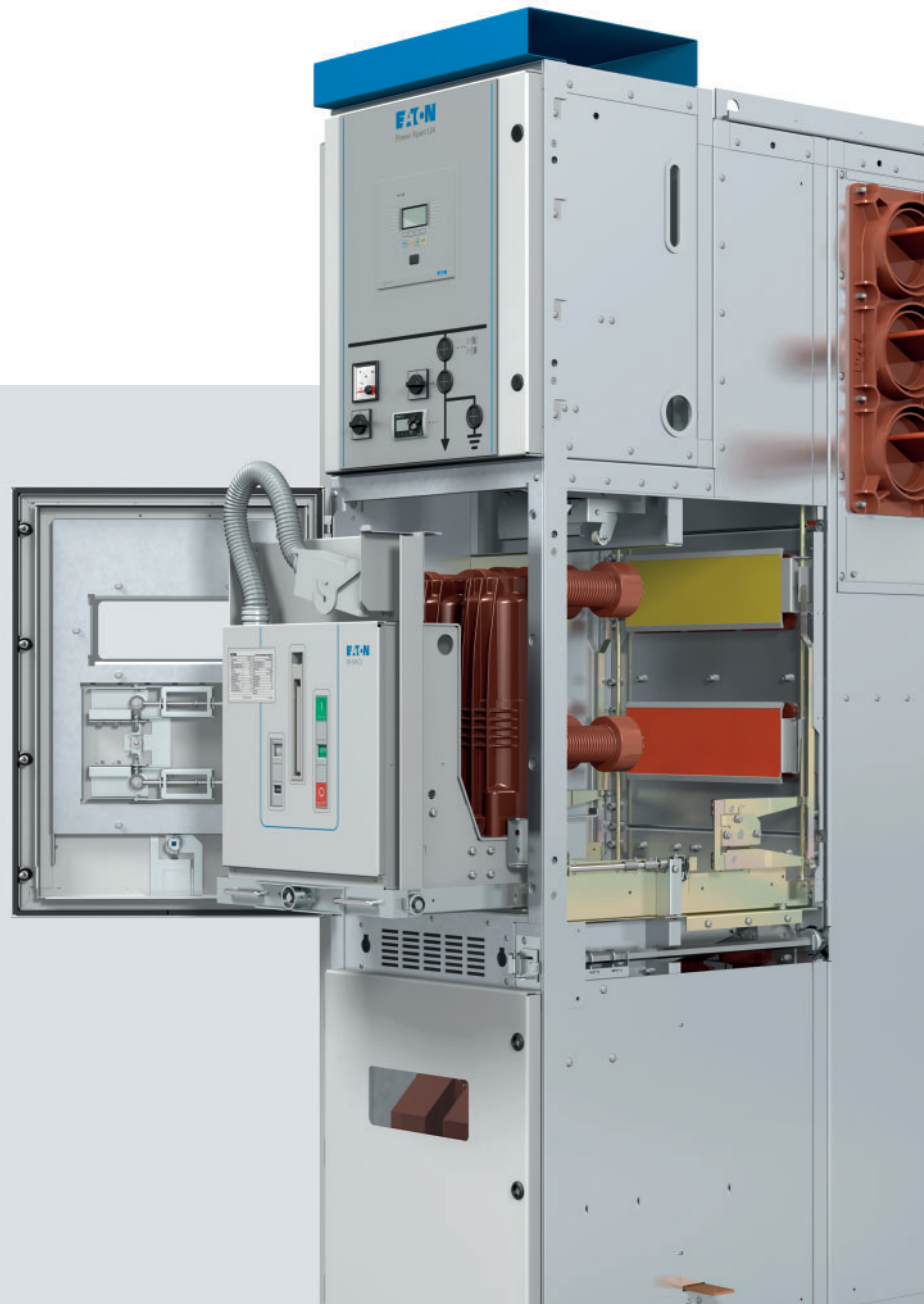

# Sustainability

## Environmentally friendly

The UX is designed to be environmentally friendly throughout the life-cycle: from production, during service and at the end-of-life.

One of Eaton's key strategic initiatives is to provide environmentally friendly products. This requires examination of the total life-cycle, from design to decommissioning.

The product life-cycle can be divided into five main blocks. These blocks are

- The design
- Materials used
- The assembly
- The operational phase
- The decommissioning

Eaton's production plants act entirely in accordance with the rules and procedures of the ISO 14001 environmental certificate during development and production processes.



## Environmentally friendly design

Material selection and the number of parts that are used to manufacture the UX are critical to determining how environmentally friendly the manufacturing process is.

Eaton selects its materials to ensure that they have the

lowest possible impact on the environment. It is essential that they are equally safe for people - not just during use, but at the end of service life too.

Within UX and the W-VACi circuit breaker, a combination of solid (cast-resin) and air is used

as insulation. The cast-resin technology, in combination with electrical field calculations, provides a very compact, environmentally friendly design for the circuit breaker and the switchgear. Because the switching medium - vacuum - is

used, UX can be completely recycled at the end of its life without any issues relating to safety procedures, special handling or safe disposal.

## No use of SF<sub>6</sub>-gas for insulation or switching

From the very beginning Eaton made a fundamental choice not to use SF<sub>6</sub> as a switching and insulation medium for medium voltage equipment - it is on the list of greenhouse gasses in the Kyoto protocol and is the most potent of the six main greenhouse gasses, with a Global Warming Potential (GWP) of 23,000.

Some medium voltage switchgear systems use SF<sub>6</sub> gas as the insulating medium. Leakage of SF<sub>6</sub> gas from switchgear contributes significantly to the threat of the greenhouse effect and associated climate change. They also require additional safety measures and special handling requirements at the end of life.



## Minimum service checks on site

UX is designed for a lifetime of at least 30 years; therefore the energy usage for maintenance activities during this long period is minimal. Due to the green insulation and switching technology, there is also no leakage of the harmful SF<sub>6</sub> gas during its lifetime and no need for performing extra maintenance activities on SF<sub>6</sub> gas pressure checks.

## Minimal energy loss during operation

The number of electrical contact or changeover points within the UX system has been kept to an absolute minimum. This reduces the potential number of "hot spots" and prevents additional energy loss associated with contact surfaces.

## Energy efficient assembly

UX is produced in an energy efficient environment. Standard processes and materials are used in the design and require no special handling or manufacturing processes, thus reducing the amount of energy required to manufacture and assemble the switchgear.

## Efficient use of materials

Besides the energy sources, special focus is placed on the efficient use of material during assembly. For example by using advanced nesting tools the sheet steel plates are cut with the least amount of waste, and similar principles are followed in the design and manufacture of other product components.

## Re-use or recycling of materials

All materials within UX can be re-used or recycled. Because the UX uses no SF<sub>6</sub> gas, there is no possibility of leakage of this greenhouse gas during decommissioning the switchgear.



# Low total cost of ownership

Designed to provide at least 30 years of reliable service the UX design guarantees low overall cost of ownership when considered over the lifetime of the switchgear.

Life-time costs can be split into initial costs, costs incurred during service and finally, costs for disposal of the switchgear. All costs of ownership are influenced by different features of the switchgear provided with no concession to quality and reliability.



## Low initial costs

### Panel dimensions

With panel dimensions of 600 mm, 800 mm and 1000 mm with only 3 depths of panel across all ratings of 1320 mm, 1500 mm and 1550 mm, UX is one of the most compact designs of air insulated medium voltage switchgear available today. The compact design of UX allows for smaller switchrooms to be built further reducing the overall cost of installation.

### Flexible cable access

The UX offers top and bottom cable entry with cable access from either front or rear. If front access is chosen it is possible to mount the UX panels flush against the wall thus reducing further the space needed in the building.

## Low cost during service

Costs during service of switchgear can accumulate due to damaged parts requiring replacement, or by maintenance cycles set up for critical parts that will not reach their expected lifetime without being serviced.

Keeping this in mind during the initial design of the UX, the first design steps undertaken were to:

- Minimise the number of parts used in the construction
- Design using industry standard or readily available raw materials
- Prevent internal parts from being damaged during the lifetime of the unit.

This robust construction, using only the minimum number of parts, is based on our long experience of building switchgear. During production of the panels, routine tests are carried out by specialists, to ensure that the panels achieve the quality that they are designed for.

## Minimal inspection

By designing a simple, modular, efficient, proven, low energy spring charged mechanism with the fewest possible number of parts for the vacuum circuit breaker, the maintenance requirements normally associated with this type of mechanism is dramatically reduced.

With proven reliability of up to 20,000 operations the Universal Mechanism Assembly used in the W-VAC*i* breaker helps to provide a virtually maintenance-free circuit breaker.

Vacuum interrupter design plays an important role in the reduction of maintenance. Eaton's vacuum interrupters employ a 'diffuse discharge' design which practically eliminates contact wear. Coupled with the proven solid insulation technology Eaton employs in the manufacture of the encapsulated pole unit, the W-VAC*i* range of vacuum circuit breakers is considered virtually maintenance free.

Switchgear that uses SF<sub>6</sub> gas as an insulation medium has an inherent leakage rate. To maintain an adequate insulation level within this type of switchgear, the pressure of the SF<sub>6</sub> gas present in the switchgear tanks must be checked and refilled on a regular basis during the unit's lifetime.

With UX the extra costs involved in checking and maintaining the required insulation level are not incurred. The combination of vacuum interrupters for switching, cast-resin technology and clean air as the insulation medium, is environmentally friendly and maintains the same quality level during the complete lifetime of UX. By not using SF<sub>6</sub> gas in UX, an owner is also not faced with the administration costs involved in registering the number of kilograms of SF<sub>6</sub> gas in the installation.

## Low disposal cost

UX switchgear has a typical lifetime of at least 30 years. Depending on the location of the installation, this lifetime can be extended. If, for any reason, a decision is made not to use the switchgear any further it can be fully recycled.

When decommissioned, the switchgear can be dismantled and the different materials can either be re-used or recycled with total safety. Because no SF<sub>6</sub> gas is used, decommissioning is a less complicated, more cost effective and an environmentally friendly operation. There are no special precautions, tools or decommissioning methods required.

# Flexibility in design

Every application of this type of system is unique, so Eaton offers a wide range of different panel types and field versions.

If, in due course, additional capacity in the form of more panels is required, UX can easily be extended to the right or left with only minimal disruption to the supply for final connection of the busbars.

Eaton realises that customers often have their own requirements with respect to the use of protection and control components within switchgear, so the need for specific components was taken into account during product development and resulted in a basic primary design that enables customers to integrate secondary protection and control components according to their own specification requirements.

## Range of voltage transformers

All UX panels can be fitted with cast-resin insulated voltage transformers, of the requested transformer ratio and class, for voltage measurement on the cable side, or on the busbar side.

The standard configuration is for a fixed voltage transformer with withdrawable fuses - although an option for truck mounted withdrawable voltage transformers is also available.



## Range of current transformers

In order to provide protection and metering, the cast-resin insulated current transformers are housed in the fixed section near the feeder cable terminals. All common transformer ratios, outputs, rated currents and classes are possible. For higher current ratings above 2500 A cast-resin ring-type current transformers are used.

It is also possible, as an option, to fit low voltages wire-wound current transformers onto a screened primary conductor instead of the standard cast-resin block or ring type transformers.

## Smart Grids and substation automation

Equipment for remote communication between panels or automation systems can also be installed in the low voltage compartment, making the system the perfect solution for current and future Smart Grid applications.

## Protection and control equipment

The protection and control equipment is located in a completely separate low voltage compartment with its own access door. There is space on the door for a mimic diagram and for mounting equipment such as protection relays, voltage detection systems, meters, etc.

In case additional space is required, the low voltage compartment can be extended.



## Standards

### UX complies with the following international standards

IEC 62271-1	Common specifications
IEC 62271-100	Circuit breakers (E2, M2, C2)
IEC 62271-102	Disconnectors and earthing switches (E2, M0)
IEC 62271-200	Metal enclosed switchgear and controlgear
IEC 60044-1	Current transformers
IEC 60044-2	Voltage transformers
IEC 60529	Degrees of protection (IP Code)
IEC 61850	Communication networks and systems in substations
IEC 61243-5	Live working - voltage detectors - Part 5: voltage detecting systems



## Electrical Data

System		12 kV	17.5 kV	24 kV
Rated voltage	kV	12	17.5	24
Lightning impulse withstand voltage	kV	75	95	125
Power frequency withstand voltage	kV	28	38	50
Rated frequency	Hz	50/60	50/60	50/60
Internal arc class			AFLR	
Loss of service continuity category			LSC2B	
Partition class			PM	
Earthing circuit	kA - s	25 - 3; 26.3 - 3; 31.5 - 3; 40 - 3; 50 - 1		20 - 3; 25 - 3

### Accessibility of compartments

Circuit breaker compartment			Interlock-controlled	
Busbar compartment			Tool-based/non-accessible	
Cable compartment			Tool-based or Interlock-controlled	
External degree of protection			IP4X (IP41 / IP42 as an option)	
Internal degree of protection			IP2X	
Installation			Indoor	
Temperature classification	°C		-5 to +40	
Relative humidity (max)	%		95	

### Busbar system

Rated normal current	A	1250, 1600, 2000, 2500, 3150, 4000 (FC <sup>[1]</sup> )		1250, 2000, 2500
Rated short-time withstand current	kA - 3 s	25 / 26.3 / 31.5 / 40 / 50		20 / 25
Rated peak withstand current	kA/50 Hz	63 / 66 / 80 / 100 / 125		63 / 80
	kA/60 Hz	65 / / 82 / 104 / 130		65 / 82

### Circuit breaker ratings

Rated normal current	A	630, 1250, 2000, 2500, 3150, 4000 (FC <sup>[1]</sup> )		800, 1250, 2000, 2500
Rated short-circuit breaking current	kA	26.3 / 31.5 / 40 / 50		20 / 25
Rated short-circuit making current	kA	65 / 82 / 104 / 130		65 / 82
Rated short-time withstand current	kA - 3 s	26.3 / 31.5 / 40 / 50		20 / 25
Single capacitor bank switching	C2 A	400		
Multiple capacitor bank switching back to back	C1 A	400		
Class				S1, E2
Auxiliary voltage	V		110/120/127 Vac 50/60Hz, 208/220/240 Vac 50/60Hz, 24/48/60 Vdc, 110/125 Vdc, 220/250 Vdc	

### Mechanism

Rated operating sequence	A		O - 0.3s - CO - 15s - CO	
Class			M2	
Number of operations			up to 20,000	
Number of operations interrupter			up to 20,000	

[1] FC = Fan cooled.

## Dimensions (mm)

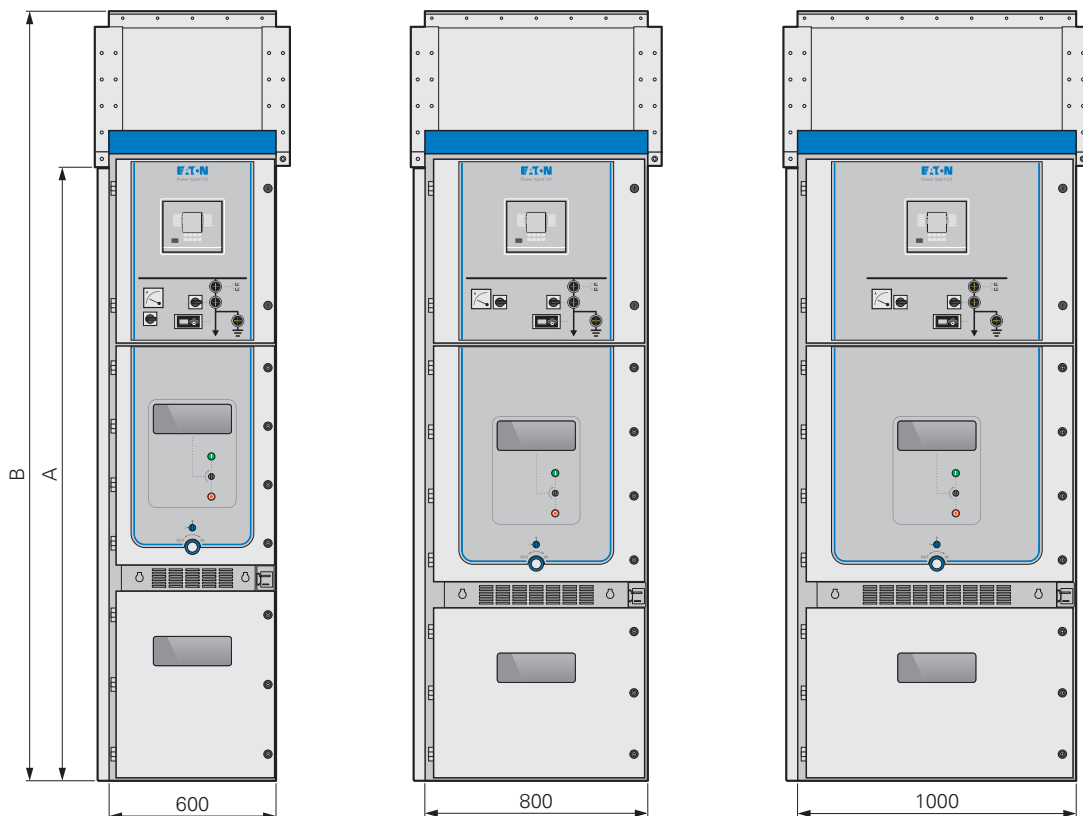

Panel width	600 mm	800 mm	1000 mm
<b>12 kV and 17.5 kV</b>			
<b>Max. rating</b>	<b>630 A / 1250 A</b>	<b>2000 A</b>	<b>3150 A / 4000 A (FC)</b>
Depth	1320 / 1500	1320 / 1500*	1500
Height (A)	2200	2200	2200
Height including arc chamber (B)	2760	2760	2760
<b>24 kV</b>			
<b>Max. rating</b>		<b>800 A / 1250 A</b>	<b>2000 A / 2500 A</b>
Depth		1570	1570
Height (A)		2320	2320
Height including arc chamber (B)		2870	2870

\*) 1500 mm for IAC classification ratings of 40 kA - 1 s and 50 kA - 1 s only.

## Weights (kg)

Circuit breaker panel				Max weight including circuit breaker
<b>12 kV and 17.5 kV</b>				
UX17	25 kA	630 A	600 mm wide	860
UX17	31.5 kA	1250 A	600 mm wide	880
UX17	40 kA	2000 A	800 mm wide	1200
UX17	50 kA	2000 A	800 mm wide	1230
UX17	40 kA	3150 A	1000 mm wide	1650
UX17	50 kA	3150 A	1000 mm wide	1650
<b>24 kV</b>				
UX24	20 kA	800A	800 mm wide	1460
UX24	25 kA	1250 A	800 mm wide	1480
UX24	25 kA	2000 A	1000 mm wide	1820
UX24	25 kA	2500 A	1000 mm wide	1820

## Product range

The UX product range is very flexible and has a variety of circuit options that enable almost all types of application to be configured.

The truck design is common for all the types enabling the reconfiguration of the panel while in service.

Flexibility is provided by the Equipped Riser Panel option. In this configuration any standard equipment truck can be fitted into the Equipped Riser, offering options for busbar

metering, earthing, and a disconnect truck.

A wide range of additional options are also available for mounting within the main primary compartments. The low voltage control and protection compartment also offers many options for control and indication.

## Panel configurations

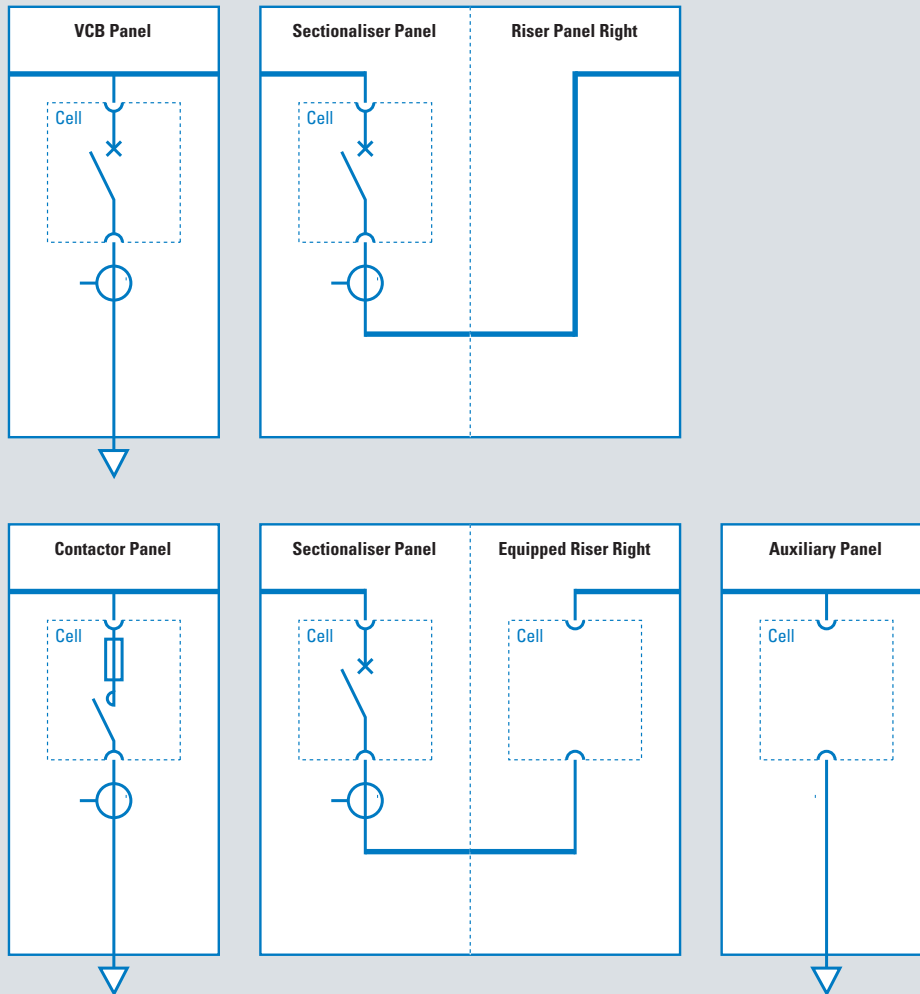

## Truck configurations

