

# IGS-9848GPF(X) Series

➤ **Industrial 20-port managed Gigabit Ethernet switch with 8x10/100/1000Base-T(X) ports and 4x100/1000Base-X SFP socket and 8x 100Base-FX or 8x1000Base-X fiber ports**

## Features

- Supports **O-Ring** (recovery time < 30ms over 250 units of connection) and MSTP(RSTP/STP compatible) for Ethernet Redundancy
- **Open-Ring** support the other vendor's ring technology in open architecture
- **O-Chain** allow multiple redundant network rings
- Support standard IEC 62439-2 **MRP** (Media Redundancy Protocol) function
- Support IEEE 1588v2 clock Synchronization
- Supports IPV6 new internet protocol version
- Support Modbus TCP protocol
- Provided HTTPS/SSH protocol to enhance network security
- Support IEEE 802.3az **Energy-Efficient Ethernet** technology
- Supports SMTP client
- Supports IP-based bandwidth management
- Supports application-based QoS management
- Supports Device Binding security function
- Supports DOS/DDOS auto preven<sup>o</sup>tion<sup>o</sup>
- IGMP v2/v3 (IGMP snooping support) for filtering multicast traffic
- Supports SNMP v1/v2c/v3 & RMON & 802.1Q VLAN Network Management
- Support ACL, TACACS+ and 802.1x User Authentication for security
- Supports 9.6K Bytes Jumbo Frame
- Multiple notification for warning of unexpected event
- Web-based , Telnet, Console (CLI), and Windows utility (Open-Vision) configuration
- Support LLDP Protocol
- Rigid IP-30 housing design
- DIN-Rail and wall mounting enabled



## Introduction

IGS-9848GPF(X) series are managed redundant ring Ethernet switch with 8x10/100/1000Base-T(X) ports and 4x100/1000Base-X SFP ports and 8x100Base-FX (IGS-9848GPF(X) series) or 8x1000Base-X (IGS-9848GPF series) optical fiber port with SC connector. With completely support of Ethernet Redundancy protocol, O-Ring (recovery time < 30ms over 250 units of connection) and MSTP (RSTP/STP compatible) can protect your mission-critical applications from network interruptions or temporary malfunctions with its fast recovery technology. And support wide operating temperature from -40 to 70°C. IGS-9848GPF(X) series can also be managed centralized and convenient by Open-Vision, Except the Web-based interface, Telnet and console (CLI) configuration. Therefore, the switch is one of the most reliable choice for highly-managed and Fiber Ethernet application.

- **O-Ring** : O-Ring is ORing's proprietary redundant ring technology, with recovery time of less 30 milliseconds and up to 250 nodes. The O-Ring redundant ring technology can protect mission-critical application from network interruptions or temporary malfunction with its fast recovery technology.

- **Open-Ring** : Open-Ring is an enhanced redundant technology that makes ORing's switches compatible with other vendor's proprietary redundant ring technologies. It enables ORing's switches to form a single ring with other vendor's switch. In cases where the ring is setup using proprietary technology, ORing offers a compatibility service where ORing can make its switches compatible with your particular network requirements.
- **O-Chain** : O-Chain is the revolutionary network redundancy technology that provides the add-on network redundancy topology for any backbone network, O-Chain allows multiple redundant network rings of different redundancy protocols to join and function together as a larger and more robust compound network topology. O-Chain providing ease-of-use while maximizing fault-recovery swiftness, flexibility, compatibility, and cost-effectiveness in one set of network redundancy topology.
- **MRP** : Media Redundancy Protocol (MRP) is a data network protocol standardized by the IEC 62439-2. It allows rings of Ethernet switches to overcome any single failure with recovery time much faster than achievable with Spanning Tree Protocol.
- **IP-based Bandwidth Management** : The switch provide advanced IP-based bandwidth management which can limit the maximum bandwidth for each IP device. User can configure IP camera and NVR with more bandwidth and limit other device bandwidth.
- **Application-Based QoS** : The switch also support application-based QoS. Application-based QoS can set highest priority for data stream according to TCP/UDP port number.
- **Device Binding Function** : ORing special Device Binding function can only permit allowed IP address with MAC address to access the network. Hacker cannot access the IP surveillance network without permission. It can avoid hacker from stealing video privacy data and attacking IP camera, NVR and controllers.
- **Advanced DOS/DDOS Auto Prevention** : The switch also provided advanced DOS/DDOS auto prevention. If there is any IP flow become big in short time, the switch will lock the source IP address for certain time to prevent the attack. It's hardware based prevention so it can prevent DOS/DDOS attack immediately and completely.
- **IEEE 1588v2 Technology** : The IEEE 1588v2 technology can fulfill precision time synchronization requirements for protection and control applications.
- **Modbus TCP** : This is a Modbus variant used for communications over TCP/IP networks.
- **IEEE 802.3az Energy-Efficient Ethernet** : This is a set of enhancements to the twisted-pair and backplane Ethernet family of networking standards that will allow for less power consumption during periods of low data activity. The intention was to reduce power consumption by 50% or more.

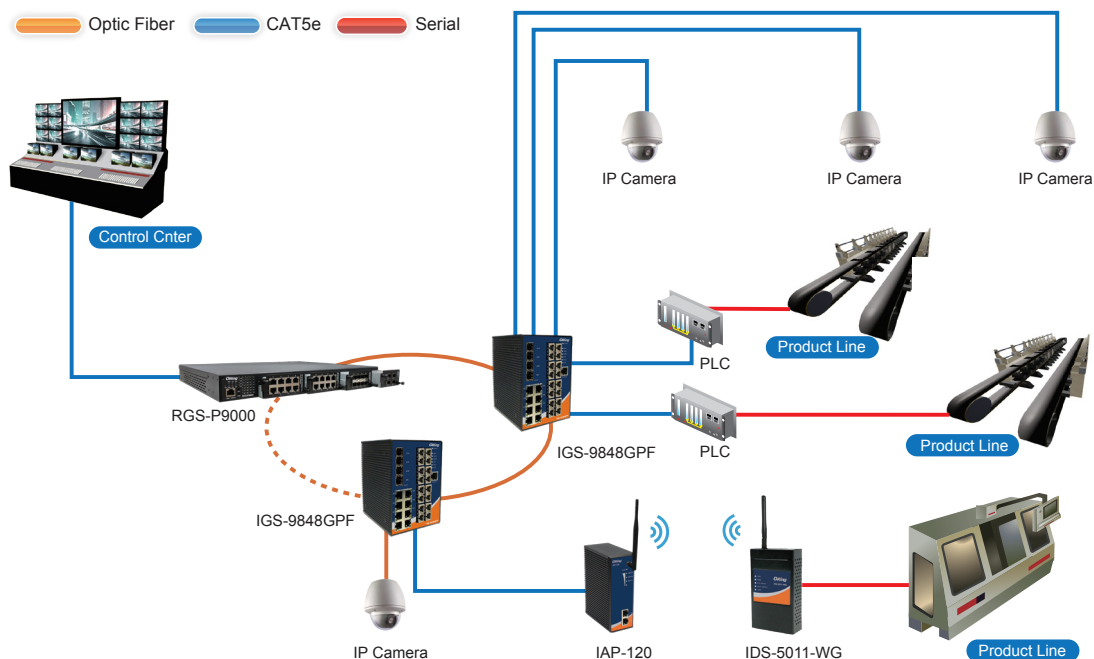

## Dimensions

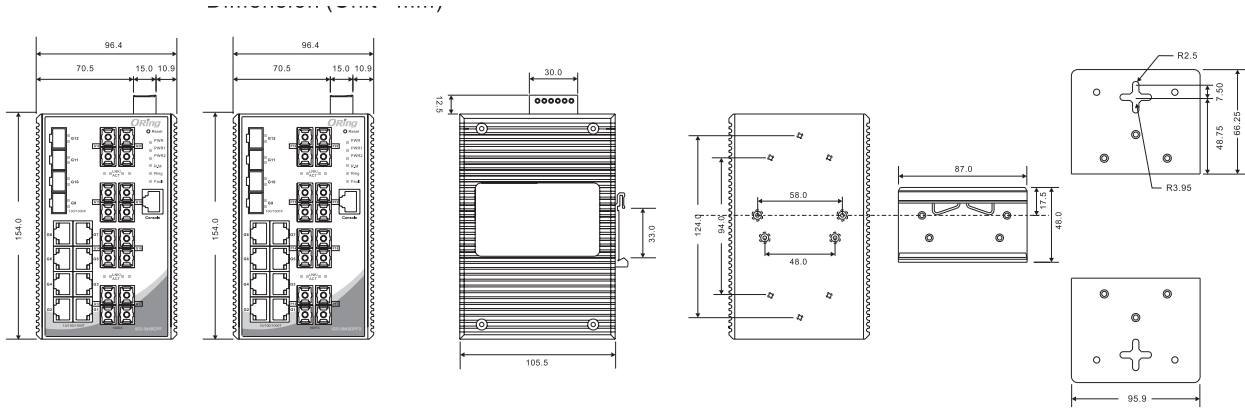

(Unit=mm)

## Open-Vision

ORing's switches are intelligent switches. Different from other traditional redundant switches, ORing provides a set of Windows utility (Open-Vision) for user to manage and monitor all of industrial Ethernet switches on the industrial network.

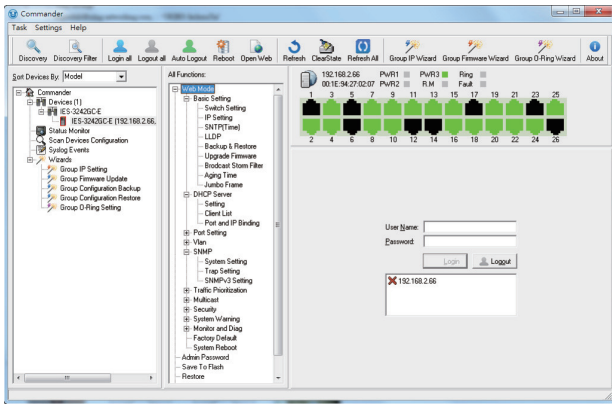

Commander

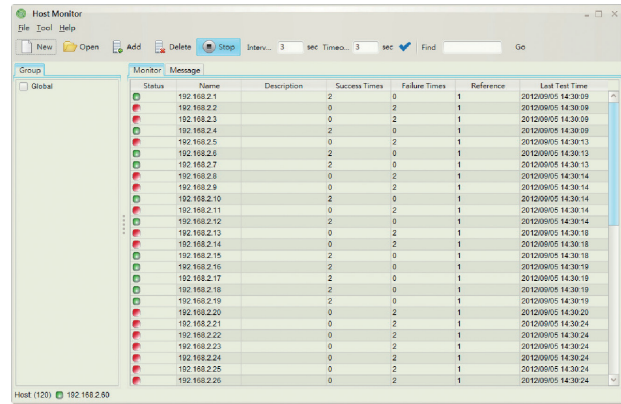

Host Monitor

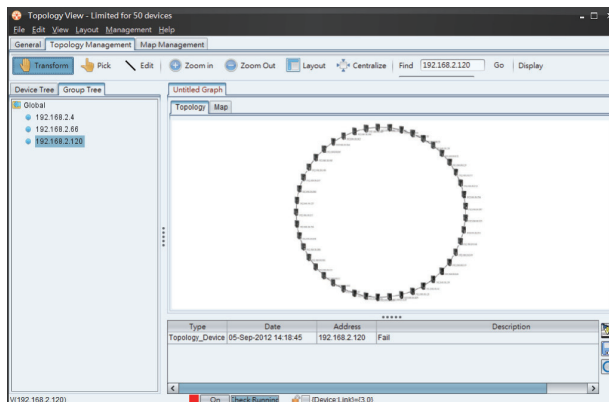

Topology View

## Specifications

ORing Switch Model		IGS-9848GPF-MM	IGS-9848GPFX-MM	IGS-9848GPF-SS	IGS-9848GPFX-SS
<b>Physical Ports</b>					
10/100/1000Base-T(X) Ports in RJ45 Auto MDI/MDIX		8	8	8	8
100/1000Base-X with SFP port		4	4	4	4
Fiber Ports Specifications	Fiber Ports Number	8	8	8	8
	Fiber Ports Standard	1000Base-SX	100Base-FX	1000Base-LX	100Base-FX
	Fiber Mode	Multi-mode	Multi-mode	Single-mode	Single-mode
	Fiber Diameter (μm)	62.5/125 μm 50/125 μm	62.5/125 μm 50/125 μm	9/125 μm	9/125 μm
	Fiber Optical Connector	SC	SC	SC	SC
	Typical Distance (km)	0.55 km	2 km	10 km	30 km
	Wavelength (nm)	850 nm	1310 nm	1310 nm	1310 nm
	Max. Output Optical Power (dBm)	-4 dBm	-14 dBm	-3 dBm	-8 dBm
	Min. Output Optical Power (dBm)	-9.5 dBm	-23.5 dBm	-9.5 dBm	-15 dBm
	Max. Input Optical Power (Saturation)	0 dBm	0 dBm	-3 dBm	0 dBm
	Min. Input Optical Power (Sensitivity)	-18 dBm	-31 dBm	-20 dBm	-34 dBm
	Link Budget (dB)	8.5 dB	7.5 dB	10.5 dB	19 dB
<b>Technology</b>					
Ethernet Standards	IEEE 802.3 for 10Base-T IEEE 802.3u for 100Base-TX and 100Base-FX IEEE 802.3ab for 1000Base-T IEEE 802.z for 1000Base-X IEEE 802.3x for Flow control IEEE 802.3ad for LACP (Link Aggregation Control Protocol) IEEE 802.1p for COS (Class of Service) IEEE 802.1Q for VLAN Tagging IEEE 802.1w for RSTP (Rapid Spanning Tree Protocol) IEEE 802.1s for MSTP (Multiple Spanning Tree Protocol) IEEE 802.1x for Authentication IEEE 802.1AB for LLDP (Link Layer Discovery Protocol)				
MAC Table	8K				
Priority Queues	8				
Processing	Store-and-Forward				
Switch Properties	Switching latency: 7 us Switching bandwidth: 40Gbps Max. Number of Available VLANs: 256 IGMP multicast groups: 128 for each VLAN Port rate limiting: User Define Https / SSH enhance network security				
Jumbo frame	Up to 9.6K Bytes				
Security Features	Device Binding security feature Enable/disable ports, MAC based port security Port based network access control (802.1x) VLAN (802.1Q) to segregate and secure network traffic Radius centralized password management SNMPv3 encrypted authentication and access security Https / SSH enhance network security				

Software Features	STP/RSTP/MSTP (IEEE 802.1D/w/s) Redundant Ring (O-Ring) with recovery time less than 30ms over 250 units TOS/Diffserv supported Quality of Service (802.1p) for real-time traffic VLAN (802.1Q) with VLAN tagging and GVRP supported IGMP Snooping IP-based bandwidth management Application-based QoS management DOS/DDOS auto prevention Port configuration, status, statistics, monitoring, security DHCP Server/Client/Relay SMTP Client Modbus TCP
Network Redundancy	O-Ring Open-Ring O-Chain MRP MSTP (RSTP/STP compatible)
RS-232 Serial Console Port	RS-232 in RJ45 connector with console cable. 115200bps, 8, N, 1
<b>LED Indicators</b>	
Power Indicator(PWR)	Green : Power LED x 2
Ring Master Indicator (R.M.)	Green : Indicates that the system is operating in O-Ring Master mode
O-Ring Indicator (Ring)	Green : Indicates that the system operating in O-Ring mode Green Blinking : Indicates that the Ring is broken.
Fault Indicator(Fault)	Amber : Indicate unexpected event occurred
10/100/1000Base-T(X) RJ45 Port Indicator	Up Green LED for Link/Act indicator. Down dual color LED : Green for 1000Mbps indicator, Amber for 10/100Mbps indicator
100/1000Base-X SFP Port Indicator	Green for port Link/Act.
100Base-FX or 1000Base-X Fiber Port Indicator	Green for port Link/Act.
<b>Fault Contact</b>	
Relay	Relay output to carry capacity of 1A at 24VDC
<b>Power</b>	
Redundant Input Power	Dual DC inputs. 12~48 VDC on 6-pin terminal block
Power Consumption (Typ.)	15 Watts
Overload Current Protection	Present
Reverse Polarity Protection	Present
<b>Physical Characteristics</b>	
Enclosure	IP-30
Dimensions (W x D x H)	96.4 (W) x 105.5 (D) x 154 (H) mm (3.8 x 4.15 x 6.06 inch)
Weight (g)	1250 g
<b>Environmental</b>	
Storage Temperature	-40 to 85°C (-40 to 185°F)
Operating Temperature	-40 to 70°C (-40 to 158°F)
Operating Humidity	5% to 95% Non-condensing
<b>Regulatory Approvals</b>	
EMI	FCC Part 15, CISPR (EN55022) class A
EMS	EN61000-4-2 (ESD), EN61000-4-3 (RS), EN61000-4-4 (EFT), EN61000-4-5 (Surge), EN61000-4-6 (CS), EN61000-4-8, EN61000-4-11
Shock	IEC60068-2-27
Free Fall	IEC60068-2-32
Vibration	IEC60068-2-6
Safety	EN60950-1
Warranty	5years

## Ordering Information

IGS-9 **A** **B** **C** **D** **E** **E** **-FF-** **GG**

Code Definition	10/100/1000Base-T(X) Port Number	Additional Port 1 Number	Additional Port 2 Number	Additional Port 1 Type	Additional Port 2 Type	Fiber Optical Mode	Fiber Optical Connector
<b>Option</b>	- <b>8</b> : 8 ports	- <b>4</b> : 4 ports	- <b>8</b> : 8 ports	- <b>GP</b> : 100/1000Base-X SFP port	- <b>F</b> : 1000Base-X fiber port - <b>FX</b> : 100Base-FX fiber port	- <b>MM</b> : Multi-mode - <b>SS</b> : Single-mode	- <b>SC</b> : SC connector

	Model Name	Description
Available Model	IGS-9848GPFX-MM-SC	Industrial 16-port managed Gigabit Ethernet switch with 8x10/100/1000Base-T(X) ports and 4x100/1000Base-X SFP socket and 8x100Base-FX, multi-mode, 2km/1310nm, SC connector
	IGS-9848GPFX-SS-SC	Industrial 16-port managed Gigabit Ethernet switch with 8x10/100/1000Base-T(X) ports and 4x100/1000Base-X SFP socket and 8x100Base-FX, single-mode, 30Km/1310nm, SC connector
	IGS-9848GPF-MM-SC	Industrial 16-port managed Gigabit Ethernet switch with 8x10/100/1000Base-T(X) ports and 4x100/1000Base-X SFP socket and 8x1000Base-SX, multi-mode, 550m/850nm, SC connector
	IGS-9848GPF-SS-SC	Industrial 16-port managed Gigabit Ethernet switch with 8x10/100/1000Base-T(X) ports and 4x100/1000Base-X SFP socket and 8x1000Base-LX, single-mode, 10Km/1310nm, SC connector

### Packing List

- IGS-9848GPF(X)
- DIN-Rail Kit
- Wall-mount Kit
- Console Cable
- ORing Tool CD
- Quick Installation Guide

### Optional Accessories (Can be purchased separately)

- Open-Vision M500, Powerful Network Management Windows Utility Suite, 500 IP devices
- SFP100 series, 100Mbps SFP optical transceiver
- SFP1G series, 1Gbps SFP optical transceiver
- DR-45 series, 45W DIN-Rail power supply
- DR-75 series, 75W DIN-Rail power supply
- DR-120 series, 120W DIN-Rail power supply