

iConverter® GX/X User Manual

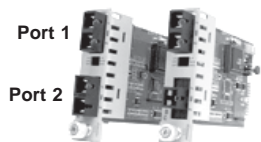

ABOUT THIS MANUAL

This document supports revision “xx/10” of the GX/X. Please refer to the serial number label on the GX/X for the revision number of your product. This revision incorporates the following improvements to the GX/X:

1. Product enhancements now prevent unpredictable behavior under undefined or incompatible DIP-Switch selections.
2. LINK MODES have been increased to include RFD+LS and RFD+LP modes. Improvements to LED behavior have been made to accommodate these new link modes.

OVERVIEW

The *iConverter* GX/X manageable two-port Gigabit Ethernet switch and media converter is a member of the modular *iConverter* product family. It provides fiber-to-fiber conversion for extending network distances and connecting dissimilar fiber network connections. The *iConverter* GX/X regenerates, reshapes and re-times the fiber optic signal, and multiple GX/X converters can be cascaded to extend total network distances.

The GX/X can be used as a standard two-port fiber converter. It can also use its two additional 10/100 backplane ports to connect to adjacent modules and accommodate flexible network configurations like In-Band management and multi-module configurations. The *iConverter* 19-Module, 5-Module or 2-Module Chassis have backplanes that facilitate connectivity between adjacent modules.

The GX/X can be used in an unmanaged or managed fashion. When unmanaged, it can be installed in a chassis without a management module and can be configured by using two onboard DIP-Switches. To be managed, a Network Management Module (NMM) or an *iConverter* module with built-in management (such as a GX/TM or 10/100M) must be installed in the same chassis.

Advanced Features

The GX/X features Port VLAN and Tag VLAN, which allow control of traffic flow among the fiber ports and chassis backplane ports. It also features Port Access Control, which facilitates enabling and disabling of individual ports.

The GX/X supports reporting of MIB statistics. Statistics are available for 32 variables per port, reporting a wide range of real-time packet statistics to provide performance and operational monitoring.

NOTE: Using the advanced features listed above requires the use of an NMM or an iConverter module with built-in management (such as a GX/TM or 10/100M) and NetOutlook™ Management Software, or third-party SNMP management software or Telnet.

For information on using and configuring these advanced features, please refer to the NetOutlook Management Software user manual.

Fig. 1 depicts a chassis with three modules plugged into three of its adjacent backplane slots (beginning with an odd-numbered slot). The adjacent slots are connected via the backplane using the “A” and “B” 10/100 links. In this example, the module on the left is a Network Management Module (NMM) connecting via its A backplane port to the GX/X, facilitating “In-Band” management (via the fiber uplink). The module on the right is a 4-port 10/100 switch module (4Tx) connecting via its B link port to the GX/X, facilitating a 4-port 10/100 Ethernet switch with a fiber uplink configuration. This 3-module configuration provides an effective 4-port 10/100 managed switch with a gigabit fiber uplink and a fiber link to another *iConverter* chassis configuration in a daisy chain.

This example shows how the GX/X can be used either as a traditional managed or unmanaged media converter or as a building block to create flexible and effective network switch configurations.

For more information on individual chassis A and B backplane links, refer to the specific chassis’ user manual.

LINK MODES

In order to accommodate different user needs, the GX/X supports five different linking modes (see Fig. 2).

In Link Segment (LS), a port transmits a Link signal independently of any received Link at any other port. For example, the UTP transmits a Link regardless of the fiber receiving a Link [Fig. 2(a) & (b)].

In Link Propagate (LP), a port transmits a Link signal only when receiving a Link at its other port. For example,

GX/X MODEL NUMBER REFERENCE CHART

<i>iConverter</i> GX/X					
Port 1 (Fiber Type / Distance / Wavelength)	Port 2 (Fiber Type / Distance / Wavelength)	Connector Types			
		SC	MT-RJ	LC	
MM / 220m / 550m ¹ / 850nm	MM / 220m / 550m ¹ / 850nm	8542-00	8544-00	-	
MM / 220m / 550m ¹ / 850nm	SM / 12km / 1310nm	8543-10	-	-	
SM / 12km / 1310nm	SM / 12km / 1310nm	8543-11	8545-11	8547-11	
SM / 34km / 1310nm	SM / 34km / 1310nm	8543-22	-	8547-22	
SM / 34km / 1310nm	SM / 80km / 1550nm	8543-23	-	-	
SM / 80km / 1550nm	SM / 80km / 1550nm	8543-33	-	8547-33	
MM / 220m / 550m ¹ / 850nm	SM / SF / 20km / Tx 1310nm, Rx 1550nm	8550-01	-	-	
MM / 220m / 550m ¹ / 850nm	SM / SF / 20km / Tx 1550nm, Rx 1310nm	8551-01	-	-	

Consult the factory for wide temperature (-40 to 60° C) and extended temperature (-40 to +75° C) models.
When using single-fiber (SF) media converter models, the Tx wavelength on one end has to match the Rx wavelength on the other.
¹62.5/125µm, 100/140µm multimode fiber up to 220m. 50/125µm multimode fiber up to 550m. Refer to the fiber cable manufacturer for multimode distance specifications.

PORT STRUCTURE

Using a 4-port switch design, the GX/X features two front-plane 100Mbps fiber ports (Port 1 is the top port, and Port 2 is the lower port nearest the thumb screw). It also features two 10/100 Ethernet backplane ports (“A” and “B”) that can connect to adjacent modules within the same chassis.

When the GX/X “A” and “B” Ethernet backplane ports are enabled (using the “BPAEN” and “BPBEN” DIP-Switches), they connect via the backplane of the chassis to the slots on the left and right sides of the GX/X module. When another switch-based module with backplane port connections such as a second GX/X or an NMM is installed in an adjacent slot, it can be connected via the backplane to the GX/X to facilitate a multi-module configuration.

GX/X APPLICATION EXAMPLE

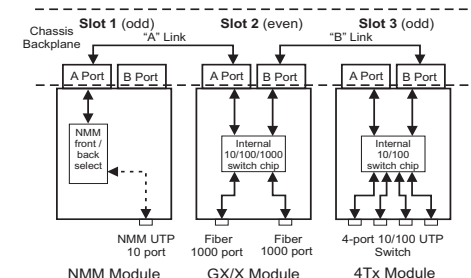

Fig. 1 In-Band Managed GX/X Application

the UTP transmits a Link only when receiving a Link at the fiber port [Fig. 2(c)].

In Remote Fault Detection + Link Segment (RFD+LS), the fiber port transmits a Link signal only when receiving a Link at the fiber port. As a result, fiber faults (no Link received at the fiber) are looped-back and can be reported to the network core [Fig. 2(d)].

In “Remote Fault Detection + Link Propagate” (RFD+LP) mode, a port transmits a Link signal only when both itself and the other port are receiving Link signals. A loss of a received Link signal at a port is “Looped-back” and the port stops transmitting a Link signal. The same loss of Link is propagated to the other port which also stops transmitting the Link signal. For example, the loss of Link into P2 causes both P1 and P2 ports to stop transmission of the Link signal [Fig. 2(e)].

NOTE: Connecting two converters with both acting in RFD mode is not supported and will cause a “deadly embrace” lockup.

When the fiber is set to Auto-Negotiation Mode, the device receiving the fault acts as if it is in RFD mode [Fig. 2(d), (e) and (f)].

NOTE: In older versions of firmware, RFD was not defined on ports set to Auto-Negotiation.

“Symmetrical Fault Detection” (SFD) mode operates similarly to the Remote Fault Detection (RFD) mode. In SFD mode, the loss of a received Link at P1 is Looped-Back to P1 and propagated to P2, causing both to stop transmitting the Link signal [Fig. 2(f)] and also causing blinking in a connected GX/X P1 “Link” LED indicator.

Connecting two converters which are both set to SFD is permitted and facilitates a dual-loop-back feature where P1 fiber faults can be reported to both ends of the network.

NOTE: Converters in SFD mode must be deployed in pairs, and the “LS” DIP-Switch position must also be selected.

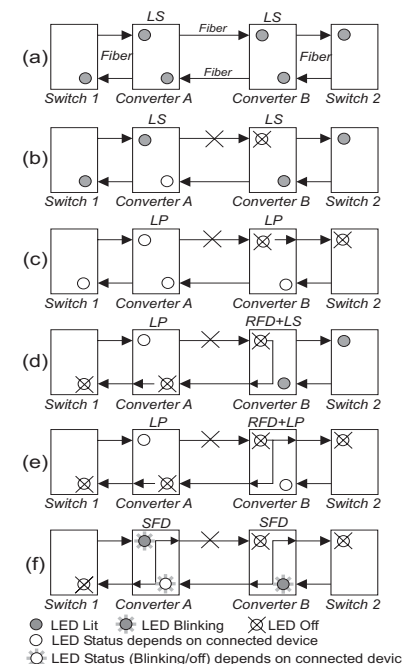

Fig. 2 GX/X Link Modes

DIP-SWITCH SETTINGS

Front Panel DIP-Switch Settings



Fig. 3 Front Panel DIP-Switches

Link Segment/Link Propagate “LS/LP” DIP-Switch

This DIP-Switch controls the Link Propagate or Link Segment modes. When the DIP-Switch is in the “LS” position (factory setting), Link Segment mode is enabled. In the “LP” position, Link Propagate mode is enabled.

Remote Fault Detection “RFD” DIP-Switch

To enable Remote Fault Detection mode, set the “RFD” DIP-Switch to the “RFD” position.

To enable RFD + LS mode, also set the LS/LP DIP-Switch to the “LS” position. To enable RFD + LP mode, set the LS/LP DIP-Switch to the “LP” position.

The RFD DIP-Switch selection is ignored on ports set to Auto-Negotiation mode.

NOTE: Connecting two converters with both set to RFD mode is not supported and will cause a “deadly embrace” lockup.

Symmetrical Fault Detection “SFD” DIP-Switch

To enable Symmetrical Fault Detection mode, set the “SFD” DIP-Switch to the “SFD” position, the “LS/LP” DIP-Switch to the “LS” position and the “RFD” DIP-Switch to the “Off” position.

Any other DIP-Switch configuration will disable Symmetrical Fault Detection mode.

NOTE: Converters in SFD mode must be deployed in pairs.

Board Mounted DIP-Switch Settings



Fig. 4 Board Mounted DIP-Switches

Backplane A Enable “BPAEN” DIP-Switch

When the “BPAEN” DIP-Switch is in the right position, the A 10/100 Ethernet backplane port is enabled. This port allows connection to an adjacent module (in the same chassis) via the backplane A link of the chassis. When the “BPAEN” DIP-Switch is in the left “off” position (factory setting), the A port is isolated from the backplane.

Backplane B Enable “BPBEN” DIP-Switch

When the “BPBEN” DIP-Switch is in the right position, the B 10/100 Ethernet backplane port is enabled. This port allows connection to an adjacent module (in the same chassis) via the chassis’ backplane B link. When the “BPBEN” DIP-Switch is in the left “off” position (factory setting), the B port is isolated from the backplane.

Fiber Port 1 Auto/Manual “ P1 AN/MAN” DIP-Switch

When the P1 AN/MAN switch is in the “AN” (left) position (factory setting) it enables Port 1 to determine duplex

mode automatically. If the device connected to Port 1 cannot provide the proper signal to indicate its own mode of operation, then the DIP-Switch should be set to the “MAN” (right) position, forcing Port 1 to Full-Duplex mode.

Fiber Port 2 Auto/Manual DIP-Switch (P2 AN/MAN)

When the P2 AN/MAN switch is in the “AN” (left) position (factory setting) it enables Port 2 to determine duplex mode automatically. If the device connected to Port 2 cannot provide the proper signal to indicate its own mode of operation, then the DIP-Switch should be set to the “MAN” (right) position, forcing Port 2 to Full-Duplex mode.

NOTE: When a fiber port is in manual mode, sometimes a link-up will not occur with other devices. Both devices must be set to the same mode (either Manual or Auto-Negotiate) for the link-up to occur.

LED INDICATORS

LED	Color	Description
Pwr:	Yellow	On--Power
F/O P1 FDX:	Green	On--Full-Duplex detected
F/O P1 Lk/Act:	Green	On--Link / Blink--activity
F/O P2 Lk/Act:	Green	On--Link / Blink--activity
F/O P2 FDX:	Green	On--Full-Duplex detected

MOUNTING AND CABLE ATTACHMENT

The *iConverter* modules are hot-swappable and can be installed into any chassis in the *iConverter* family. To install the module in a chassis, perform the following steps:

- Carefully slide the *iConverter* module into the installation slot, aligning the module with the installation guides. Ensure that the module is firmly seated against the backplane.
- Secure the module in the chassis by using the panel fastener screw (attached to the module).
- Connect the appropriate multimode or single-mode fiber cable to a 1000BASE-X Ethernet device.

NOTE: The iConverter transmit (Tx) must attach to the receive side on other device; the receive (Rx) must attach to the transmit.

- When using single-fiber (SF) media converter models, the Tx wavelength on one end has to match the Rx wavelength on the other.

NOTE: Based on this guideline, the SF media converter models must be used in pairs, such as the 8550-01 matched with the 8551-01.

GX/X SPECIFICATIONS

Model Type	GX/X
Protocols	1000BASE-SX/LX
Fiber Connectors	SC, MT-RJ, LC, Single-Fiber SC
Controls	BP Enable, LS/LP, RFD, SFD, F/O Auto/Man
LED Displays	Power, FO link, FDX/HDX
Dimensions	W:0.85" x D:4.5" x H:2.8"
Weight	8 oz.
Compliance	UL, CE, FCC Class A
Power Requirement	2.2A @ 3.3VDC (typical)
Temperature	Standard: 0 to 50° C Storage: -40 to 80° C
Humidity	5 to 95% (non-condensing)
Altitude	-100m to 4000m
MTBF (hrs)	640,000

It is recommended when connecting two GX/X modules together to use port 1 as the common port between modules (or port 1 to port 2).

The GX/X should not be installed in the 1-slot chassis because of power and heat constraints.

Warning

The operating description in this Instruction Manual is for use by qualified personnel only. To avoid electrical shock, do not perform any servicing of this unit other than that contained in the operating instructions, unless you are qualified and certified to do so by Omnitron Systems Technology, Inc.

Warranty

This product is warranted to the original purchaser against defects in material and workmanship for a period of TWO YEARS from the date of shipment. A LIFETIME warranty may be obtained by the original purchaser by REGISTERING this product with Omnitron within 90 days from the date of shipment. TO REGISTER, COMPLETE AND MAIL OR FAX THE ENCLOSED REGISTRATION FORM. Or you may register your product on the Internet at www.omnitron-systems.com. During the warranty period, Omnitron will, at its option, repair or replace a product which is proven to be defective.

For warranty service, the product must be sent to an Omnitron designated facility, at Buyer’s expense. Omnitron will pay the shipping charge to return the product to Buyer’s designated US address using Omnitron’s standard shipping method.

Limitation of Warranty

The foregoing warranty shall not apply to defects resulting from improper or inadequate use and/or maintenance of the equipment by Buyer, Buyer-supplied equipment, Buyer-supplied interfacing, unauthorized modifications or tampering with equipment (including removal of equipment cover by personnel not specifically authorized and certified by Omnitron), or misuse, or operating outside the environmental specification of the product (including but not limited to voltage, ambient temperature, radiation, unusual dust, etc.), or improper site preparation or maintenance.

No other warranty is expressed or implied. Omnitron specifically disclaims the implied warranties of merchantability and fitness for any particular purpose.

Exclusive Remedies

The remedies provided herein are the Buyer’s sole and exclusive remedies. Omnitron shall not be liable for any direct, indirect, special, incidental, or consequential damages, whether based on contract, tort, or any legal theory.

TECHNICAL SUPPORT

For help with this product, contact our Technical Support:

Phone: (949) 250-6510
 Fax: (949) 250-6514
 Address: Omnitron Systems Technology, Inc.
 140 Technology Dr., #500
 Irvine, CA 92618 USA
 E-mail: support@omnitron-systems.com
 URL: www.omnitron-systems.com