

User Guide  
6642-22521

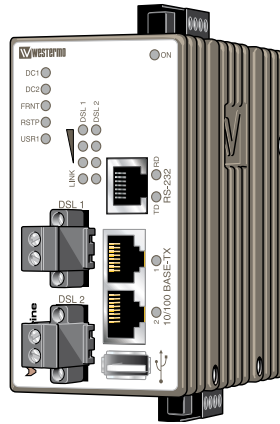

# Wolverine

## DDW-142-EX



***Industrial Ethernet Extender***

[www.westermo.com](http://www.westermo.com)



## **License Information**

This device contains public available software which is under the GPL license.

For more information see legal.pdf included with all firmware releases.

This product includes software developed by the OpenSSL Project for use in the **OpenSSL Toolkit**. <http://www.openssl.org>

## **Legal information**

The contents of this document are provided "as is". Except as required by applicable law, no warranties of any kind, either express or implied, including, but not limited to, the implied warranties of merchantability and fitness for a particular purpose, are made in relation to the accuracy and reliability or contents of this document. Westermo reserves the right to revise this document or withdraw it at any time without prior notice.

Under no circumstances shall Westermo be responsible for any loss of data or income or any special, incidental, and consequential or indirect damages howsoever caused.

More information about Westermo can be found at the following Internet address:

<http://www.westermo.com>

**6642-22501**

## Safety



### **Before installation:**

Read this manual completely and gather all information on the unit. Make sure that you understand it fully. Check that your application does not exceed the safe operating specifications for this unit.

This unit should only be installed by qualified personnel.

This unit should be built-in to an apparatus cabinet, or similar, where access is restricted to service personnel only.

The power supply wiring must be sufficiently fused, and if necessary it must be possible to disconnect manually from the power supply. Ensure compliance to national installation regulations.

This unit uses convection cooling. To avoid obstructing the airflow around the unit, follow the spacing recommendations (see Cooling section).

"Note that this unit can be connected to two different power sources."



### **Before mounting, using or removing this unit:**

Prevent access to hazardous voltage by disconnecting the unit from power supply.

**Warning!** Do not open connected unit. Hazardous voltage may occur within this unit when connected to power supply.

When this unit is operated at an ambient temperature above +60°C (+140°F), the External Surface of Equipment may exceed Touch Temperature Limit according to EN/IEC/UL 60950-1. To reduce the risk of fire, use only No. 26 AWG or larger telecommunication line cord.

## Care recommendations

Follow the care recommendations below to maintain full operation of unit and to fulfil the warranty obligations.

This unit must not be operating with removed covers or lids.

Do not attempt to disassemble the unit. There are no user serviceable parts inside.

Do not drop, knock or shake the unit, rough handling above the specification may cause damage to internal circuit boards.

Do not use harsh chemicals, cleaning solvents or strong detergents to clean the unit.

Do not paint the unit. Paint can clog the unit and prevent proper operation.

Do not expose the unit to any kind of liquids (rain, beverages, etc). The unit is not waterproof. Keep the unit within the specified humidity levels.

Do not use or store the unit in dusty, dirty areas, connectors as well as other mechanical part may be damaged.

If the unit is not working properly, contact the place of purchase, nearest Westermo distributor office or Westermo Tech support.

A readily accessible disconnect device shall be incorporated external to the equipment.

This unit may have hot surfaces when used in high ambient temperature.

## Maintenance

No maintenance is required, as long as the unit is used as intended within the specified conditions.



### **ATEX certification number**

Baseefa 14ATEX 0151x

### **Standards**

EN 60079-0:2012, EN 60079-15:2010

### **Certification code**

Ex nA IIC T4 Gc ( $-40^{\circ}\text{C} \leq \text{Ta} \leq +70^{\circ}\text{C}$ )

### **ATEX code**

 II 3G

### **Specific Conditions of Use**

The equipment must be installed in an area of not more than pollution degree 2 in accordance with IEC/EN 60664-1, and in an enclosure that provides a minimum degree of protection of at least IP54 and complies with the relevant requirements of EN 60079-0 and EN 60079-15.

All external connections to the equipment must not be inserted or removed unless either the area in which the equipment is installed is known to be non-hazardous, or the circuits connected have been de-energized.

The network cables once installed must be properly fixated by the use of cable ties or similar to reduce the risk of accidentally withdrawing the plugs.

### **Equipment input parameters**

Power Connector: +DC1, +DC2 & -COM

Working Voltage Range = 24 V to 48 VDC.

I/O Connector: 'Status +' & 'Status -' and 'Digital in +' and 'Digital in -'

Maximum I/P Voltage = 60 VDC.



## ATEX-Zulassungsnummer

Baseefa 14ATEX 0151x

## Standards

EN 60079-0:2012, EN 60079-15:2010,

## Zertifizierungscode

Ex nA IIC T4 Gc ( $-40^{\circ}\text{C} \leq T_a \leq +70^{\circ}\text{C}$ )

## ATEX-Code

 II 3G

## Spezifische Einsatzbedingungen

Die Geräte müssen in einem Bereich welcher einem maximalen Verschmutzungsgrad der Stufe 2 gemäß IEC/EN 60664-1 entspricht und in einem Gehäuse, das einen Schutzgrad von mindestens IP54 bietet und die relevanten Anforderungen von N 60079-0 und EN 60079-15 erfüllt, installiert werden.

Alle Anschlüsse des Gerätes dürfen nur dann angeschlossen oder abgeschlossen werden, wenn der Bereich, in dem das Gerät installiert ist, nachweislich ungefährlich oder das Gerät völlig spannungsfrei ist.

Die Netzkabel müssen nach der Installation mithilfe von Kabelbindern oder ähnlichem Material ordnungsgemäß befestigt werden, um ein versehentliches Abziehen der Stecker zu verhindern.

## Eingangsparameter der Geräte

Stromversorgung: +DC1, +DC2 & -COM

Betriebsspannungsbereich = 24 V to 48 VDC.

I/O-Anschluss: 'Status +' & 'Status -' und 'Digital in +' und 'Digital in -'

Maximale I/P-Spannung = 60 VDC.



**Certification ATEX**



## **Numéro de certification ATEX**

Baseefa 14ATEX 0151x

## **Normes**

EN 60079-0:2012, EN 60079-15:2010

## **Code de certification**

Ex nA IIC T4 Gc ( $-40^{\circ}\text{C} \leq T_a \leq +70^{\circ}\text{C}$ )

## **Code ATEX**

 II 3G

## **Conditions spéciales d'utilisation**

L'équipement doit être installé dans une zone où le degré de pollution ne dépasse pas le degré 2 conformément à l'IEC/EN 60664-1, et dans un boîtier qui fournit un niveau de protection au moins égal à IP54 et conforme aux exigences applicables à EN 60079-0 et EN 60079-15

Toutes les connexions externes à l'équipement ne doivent pas être insérées ou retirés sauf si la zone dans laquelle l'équipement est installé est reconnue comme non dangereuse, ou si les circuits raccordés sont hors-tension.

Une fois les câbles réseau installés, ils doivent être correctement fixé grâce à des attaches de câbles ou autre élément semblable afin de réduire le risque de débranchement accidentel.

## **Paramètres d'entrée des équipements**

Connecteur d'alimentation : +DC1, +DC2 & –COM

Double entrée d'alimentation 24 V à 48 VCC

Connecteur E/S : « Statut + » et « Statut – » et « Entrée digitale + » et « Entrée digitale – »

Tension maximale I/P = 60 VCC.



## ATEX Information

### General

This unit is intended for use in Zone 2 hazardous location only.

### Marking

 II 3G

Ex nA IIC T4 Gc

SPECIAL CONDITION

	Indicate that this unit complies with relevant European standards that are harmonised with the 94/9/EC Directive (ATEX).
<b>II</b>	Equipment group II. This unit can be installed in all places with an explosive gas atmosphere other than mines susceptible to firedamp.
<b>3</b>	Equipment category 3. A category is the classification according to the required level of protection. This unit ensures the requisite level of protection during normal operation and is intended for use in areas in which explosive atmosphere caused by gases, vapours, mists, or dust mixtures are unlikely to occur or, if they do occur, are likely to do so only infrequently and for a short period only.
<b>G</b>	Indicates protection concerning explosive atmospheres caused by gases, vapours or mists (G).
<b>Ex</b>	Indicates that this unit is in conformity with relevant European Ex standard(s).
<b>nA</b>	The type of protection used. This unit is a non-sparking device "nA" which is constructed to minimize the risk of occurrence of arcs or sparks capable of creating an ignition hazard during conditions of normal operation.
<b>IIC</b>	Gas group, a typical gas is hydrogen.
<b>T4</b>	Temperature class T4 (T4 = 135 °C). This unit is classified in accordance with its maximum surface temperature (external and internal).
<b>Gc</b>	Equipment protection level Gc (EPL Gc). Equipment for explosive gas atmospheres, having a "enhanced" level of protection, which is not a source of ignition in normal operation and which may have some additional protection to ensure that it remains inactive as an ignition source in the case of regular expected occurrences. EPL Gc are analogous to the ATEX Categories (Category 3 G = EPL Gc).
<b>SPECIAL CONDITION</b>	This unit has a special condition for safe use. The special condition for safe use contains safety related information that is necessary for the correct installation and safe use.



## **SPECIAL CONDITION FOR SAFE USE**

### *Ambient temperature:*

This unit is designed for use in extreme ambient temperature conditions according to the following:  $-40^{\circ}\text{C} \leq T_a \leq +70^{\circ}\text{C}$

### *Installation in an apparatus cabinet:*

This unit requires installation in an Ex certified apparatus cabinet suitable for the area of use and providing a degree of protection of at least IP54.

### *Resistance to impact:*

This unit requires installation in an apparatus cabinet where adequate resistance to impact is provided by the apparatus cabinet.

See "Installation in an apparatus cabinet" above for requirements on the external apparatus cabinet.

### *Resistance to light:*

This unit requires installation in an apparatus cabinet where it is protected from light (for example daylight or light from luminaires).

See "Installation in an apparatus cabinet" above for requirements on the external apparatus cabinet.

### *Secureness of plugs:*

When this unit is installed in an explosive atmospheres, all connectors must be mechanically secured to prevent loosening.

### *Conductor temperature:*

When this unit is installed in locations with high ambient temperature, special precautions shall be taken upon the choice of external conductor(s) and the temperature rating of the conductor(s).

### *Directive 94/9/EC alongside with other directives:*

Directive 2004/108/EC (EMC) applies and to assure a safe performance of this unit under the scope of Directive 94/9/EC, refer to the electromagnetic immunity level specified under "Type tests and environmental conditions" in this manual.

### *Warning marking:*

When this unit is installed in an explosive atmospheres, the warning label submitted together with this unit shall be attached on the unit and visible to the end user.

## **Standards and date of compliance**

EN 60079-0 and EN 60079-15

2011-03-24

## Agency approvals and standards compliance

Type	Approval / Compliance
EMC	EN 55024 + A1 + A2, Electromagnetic compatibility - Immunity IT equipment
	EN 55022 + A1, Information technology equipment. Radio disturbance characteristics. Limits and methods of measurement
	EN 61000-6-1, Immunity residential environments
	EN 61000-6-2, Immunity industrial environments
	EN 61000-6-4, Emission industrial environments
	EN 61000-6-3, Emission residential, commercial and light-industrial environments
	FCC part 15 Class A and Class B
	EN 50121-4, Railway signalling and telecommunications apparatus
	IEC 62236-4, Railway signalling and telecommunications apparatus
Safety	EN 60950-1
Ex	EN 60079-0 and EN 60079-15
Marine	DNV Standard for Certification no. 2.4

### FCC Part 15.105 Notice:

This equipment has been tested and found to comply with the limits for a Class B digital device, pursuant to Part 15 of the FCC Rules. These limits are designed to provide reasonable protection against harmful interference in a residential installation. This equipment generates, uses and can radiate radio frequency energy and, if not installed and used in accordance with the instructions, may cause harmful interference to radio communications. However, there is no guarantee that interference will not occur in a particular installation. If this equipment does cause harmful interference to radio or television reception, which can be determined by turning the equipment off and on, the user is encouraged to try to correct the interference by one or more of the following measures:

- ⌘ Reorient or relocate the receiving antenna
- ⌘ Increase the separation between the equipment and receiver
- ⌘ Connect the equipment into an outlet on a circuit different from that to which the receiver is connected
- ⌘ Consult the dealer or an experienced radio/TV technician for help.

# Declaration of Conformity



Westermo Teleindustri AB

## Declaration of conformity

The manufacturer Westermo Teleindustri AB  
SE-640 40 Stora Sundby, Sweden

Herewith declares that the product(s)

Type of product	Model	Article number
Industrial Ethernet SHDSL Extender	DDW-142-EX	3642-5300

is in conformity with the following EC directive(s).

No	Short name
2004/108/EC	Electromagnetic Compatibility (EMC)
94/9/EC	Equipment for explosive atmospheres (ATEX)
2011/65/EU	Restriction of the use of certain hazardous substances in electrical and electronic equipment (RoHS)

References of standards applied for this EC declaration of conformity.

No	Title	Issue
EN 61000-6-1	Electromagnetic compatibility – Immunity for residential environments	2007
EN 61000-6-2	Electromagnetic compatibility – Immunity for industrial environments	2005 + C1: 2005
EN 61000-6-3	Electromagnetic compatibility – Emission residential environments	2007
EN 61000-6-4	Electromagnetic compatibility – Emission for industrial environments	2007
EN 50121-4	Railway applications – Electromagnetic compatibility – Emission and immunity of the signalling and telecommunications apparatus	2006 + C1: 2008
EN 55022	Information technology equipment – Radio disturbance characteristics – Limits and methods of measurement	2010
EN 60079-0	Explosive atmospheres - Equipment - General requirements	2012
EN 60079-15	Electrical apparatus for explosive gas atmospheres - Construction, test and marking of type of protection "n" electrical apparatus	2010
EN 50581	Technical documentation for the assessment of electrical and electronic products with respect to the restriction of hazardous substances	2012

The last two digits of the year in which the CE marking was affixed: 14



Signature

Pierre Öberg  
Technical Manager  
22<sup>th</sup> May 2014

---

Postadress/Postal address	Tel.	Telefax	Postgiro	Bankgiro	Org.nr/ Corp. identity number	Registered office
S-640 40 Stora Sundby Sweden	016-428000	016-428001	52 72 79-4	5671-5550	556361-2604	Eskilstuna
	Int+46 16428000	Int+46 16428001				

## Type tests and environmental conditions

Electromagnetic Compatibility			
Environmental phenomena	Basic standard	Description	Test levels
Electrostatic discharge	EN 61000-4-2	Enclosure	Contact: $\pm 6$ kV Air: $\pm 8$ kV
Fast transients	EN 61000-4-4	Power port	$\pm 2$ kV
		Ethernet ports	$\pm 2$ kV
		SHDSL ports	$\pm 2$ kV
		RS-232 port	$\pm 2$ kV
		Status out / Digital in	$\pm 2$ kV
Surge	EN 61000-4-5	Power port	L-L: $\pm 0.5$ kV, 2 $\Omega$ , 18 $\mu$ F L-E: $\pm 0.5$ kV, 12 $\Omega$ , 9 $\mu$ F L-E: $\pm 2$ kV, 42 $\Omega$ , 0.5 $\mu$ F L-L: $\pm 1$ kV, 42 $\Omega$ , 0.5 $\mu$ F
		Ethernet ports	L-E: $\pm 2$ kV, 2 $\Omega$
		SHDSL ports	L-E: $\pm 2$ kV, 42 $\Omega$ , 0.5 $\mu$ F
		RS-232 port	L-E: $\pm 2$ kV, 2 $\Omega$
		Status out / Digital in	L-E: $\pm 2$ kV, 42 $\Omega$ , 0.5 $\mu$ F
Pulse magnetic field	EN 61000-4-9	Enclosure	300 A/m
Radiated RF immunity	EN 61000-4-3	Enclosure	20 V/m 80% AM, 1 kHz sine, 80 – 1000 MHz 12 V/m 80% AM, 1 kHz sine, 1000 – 2700 MHz
Conducted RF immunity	EN 61000-4-6	Power port	10 V, 80% AM, 1 kHz sine; 0.15 – 80 MHz
		Ethernet ports	10 V, 80% AM, 1 kHz sine; 0.15 – 80 MHz
		SHDSL ports	10 V, 80% AM, 1 kHz sine; 0.15 – 80 MHz
		RS-232 port	10 V, 80% AM, 1 kHz sine; 0.15 – 80 MHz
		Status out / Digital in	10 V, 80% AM, 1 kHz sine; 0.15 – 80 MHz
Voltage dips and interruption	EN 61000-4-29	DC Power port	10, 20 and 5000 ms, interruption 500 ms, 30% reduction 200 ms, 60% reduction +20 above & -20% below rated voltage
Radiated RF emission	EN 55022	Enclosure	Class B
	FCC part 15		Class B
Conducted RF emission	EN 55022	Power port	Class B
	FCC part 15		Class B
	EN 55022	Ethernet ports	Class B
	FCC part 15		Class B
Dielectric strength	EN 60950-1	Power port to other isolated ports	2000 Vrms 50 Hz 1 min
		Ethernet ports to all other isolated ports	1500 Vrms 50 Hz 1 min
		RS-232 port to all other isolated ports	
		SHDSL ports to all other isolated ports	
		Status out / Digital in port to all other isolated ports	

<b>Electromagnetic Compatibility</b>			
<b>Environmental phenomena</b>	<b>Basic standard</b>	<b>Description</b>	<b>Test levels</b>
<b>Environmental</b>			
Temperature		Operating	-40 to +70°C (-40 to +158°F)
		Storage & Transport	-40 to +85°C (-40 to +185°F)
Humidity		Operating	5 to 95% relative humidity
		Storage & Transport	5 to 95% relative humidity
Altitude		Operating	2 000 m / 70 kPa
Service life		Operating	10 years
Reliability prediction (MTBF)		Operating	437,000 hours (MIL-HDBK- 217F2, GB, 25°C)
Vibration	IEC 60068-2-64 (random)	Operating	5 – 20 Hz: 2 m <sup>2</sup> /s <sup>3</sup> 20 – 500 Hz: - 3 dB/oct 3 axis = 3 * 30 min
Shock	IEC 60068-2-27	Operating	6 ms 1000 m/s <sup>2</sup> 6 directions, 3 shocks/direction
Bump	IEC 60068-2-27	Operating	11 ms 100 m/s <sup>2</sup> 6 directions, 100 shocks/direction
<b>Packing</b>			
Enclosure material	EN 60950-1		Zinc (fire enclosure)
Dimension W x H x D		Without connectors	52.5 x 100 x 92 mm
		With connectors	52.5 x 100 x 111 mm
Weight			0.8 kg
Degree of protection	EN 60529	Enclosure	IP 40
Cooling			Convection
Mounting		Enclosure	Horizontal on 35 mm DIN-rail

# Description

## Functional description

The Wolverine DDW-142 allows effective Ethernet networks to be created over long distances up to 15 km (9.3 mi) at data rates up to 15.3 Mbit/s on a single twisted pair cable. By using two pairs “bonded” this rate can be doubled up to 30.4 Mbit/s. The integral switch allows 2 Ethernet devices to be attached and an RS-232 port allows for a legacy piece of equipment to be incorporated into the IP network.

The operating system in DDW-142 (WeOS) can deliver unique security functionality for this class of product as well as allowing the DDW-142 to form part of a resilient multimedia ring network using the Westermo FRNT protocol or industry standard STP/RSTP. WeOS has been developed to provide industrial networking solutions and contains amazing serial connectivity capability – from being able to simulate an old AT modem, convert Modbus RTU to TCP or encapsulate serial data into an IP packet.

The DDW-142 is incredibly flexible and easy to use. A basic point to point or multidrop network can be created without the need for any kind of configuration. If however a more complex solution requires some kind of network configuration the Web based setup is simple to use. A CLI interface is also provided making the unit easy for networking professionals to quickly master. Once the system is configured an easy solution is also available for the maintenance engineer – USB backup and restore means that stored configurations can be automatically downloaded from a USB stick.

The DDW-142 is often used in applications on railways, roads or with utilities where failure could result in significant costs. All Westermo products are designed with high MTBF in mind to improve operational reliability and also give long service life. Even features like the SHDSL diagnostics and management allow indication of line degradation allowing planned maintenance. As the unit is designed for these applications Westermo also ensure that testing is carried out to ensure the unit can operate at extremes of temperature, EMC and vibration and still provide robust communications.

## Interface specifications

<b>Power</b>	
Rated voltage	24 to 48 VDC
Operating voltage	19 to 60 VDC
Rated current	245 mA (405 mA) @ 24 VDC (with 500 mA USB load) 124 mA (200 mA) @ 48 VDC (with 500 mA USB load)
Rated frequency	DC
Inrush current, I <sup>2</sup> t	10.6 mA <sup>2</sup> s @ 24 VDC 24.7 mA <sup>2</sup> s @ 36 VDC 42.4 mA <sup>2</sup> s @ 48 VDC
Startup current <sup>*</sup> )	2 x Rated current
Polarity	Reverse polarity protected
Redundant power input	Yes
Isolation to	All other
Connection	Detachable screw terminal
Connector size	0.2 – 2.5 mm <sup>2</sup> (AWG 24 – 13) Connect the unit using at least 18 AWG (0.75 mm <sup>2</sup> ) wiring
Shielded cable	Not required

\* External supply current capability for proper start-up.

<b>RS-232</b>	
Electrical specification	EIA RS-232
Data rate	300 bit/s – 115.2 kbit/s
Data format	7 or 8 data bits, Odd, even or none parity, 1 or 2 stop bits
Protocol	Transparent, optimised by packing algorithm
Circuit type	SELV
Transmission range	15 m / 49 ft
Isolation to	Power, SHDSL, Ethernet
Galvanic connection to	USB, Console
Connection	RJ-45 according to EIA-561
Shielded cable	Recommended
Conductive housing	Yes
Number of ports	1

<b>Ethernet TX</b>	
Electrical specification	IEEE std 802.3. 2005 Edition
Data rate	10 Mbit/s, 100 Mbit/s, manual or auto
Duplex	Full or half, manual or auto
Circuit type	TNV-1
Transmission range	Up to 150 m, with CAT5e cable or better
Isolation to	All other
Connection	RJ-45, auto MDI/MDIX
Shielded cable	Not required, except when installed in Railway applications as signalling and telecommunications apparatus and located close to rails.*
Conductive housing	Yes
Number of ports	2

\* To minimise the risk of interference, a shielded cable is recommended when the cable is located inside 3 m boundary to the rails and connected to this port.

The cable shield should be properly connected (360°) to an earthing point within 1 m from this port.

This earthing point should have a low impedance connection to the conductive enclosure of the apparatus cabinet, or similar, where the unit is built-in. This conductive enclosure should be connected to the earthing system of an installation and may be directly connected to the protective earth.

<b>Console</b>	
Electrical specification	LVTTL/LVCMOS-level
Data rate	115.2 kbit/s
Data format	8 data bits, none parity, 1 stop bit, no flow control
Circuit type	SELV
Connection	2.5 mm jack, use Westermo cable 1211-2027

<b>USB</b>	
Electrical specification	USB 2.0 host interface
Data rate	Up to 12 Mbit/s (full-speed mode)
Circuit type	SELV
Maximum supply current	500 mA
Connection	USB receptacle connector type A



<b>I/O / Relay output</b>	
Maximum voltage/current	60 VDC / 80 mA
Connect resistance	Max 30 $\Omega$
Isolation to	All other
Connection	Detachable screw terminal
Connector size	0.2 – 2.5 mm <sup>2</sup> (AWG 24 – 13)
<b>I/O / Digital in</b>	
Maximum voltage / load current	60 VDC / 2 mA
Voltage levels	Logic one >12 V, Logic zero <1V
Isolation to	All other
Connection	Detachable screw terminal
Connector size	0.2 – 2.5 mm <sup>2</sup> (AWG 24 – 13)
<b>SHDSL</b>	
Electrical specification	ITU-T G.991.2 Annex B
Data rate	32 kbit/s to 30.4 Mbit/s with bonding
Protocol	EFM according to IEEE 802.3-2005
Transmission range	According to ITU-T G.991.2 depending on line quality
Isolation to	All other
Connection	Detachable screw terminal
Connector size	0.2 – 2.5 mm <sup>2</sup> (AWG 24 – 13)
Shielded cable	Not required
Number of ports	2

# Location of interface ports and LED's

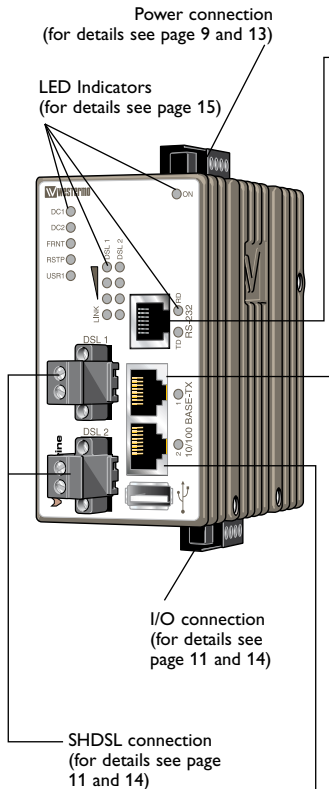

## RS-232 Connection

(for more details see also page 9)

Position	Signal	Direction*	Description
No. 1	DSR	Out	Data Set Ready
No. 2	DCD	Out	Data Carrier Detect
No. 3	DTR	In	Data Terminal Ready
No. 4	SG	–	Signal Ground, not chassis ground
No. 5	RD	Out	Receive Data
No. 6	TD	In	Transmit Data
No. 7	CTS	Out	Clear To Send
No. 8	RTS	In	Request To Send

### Female

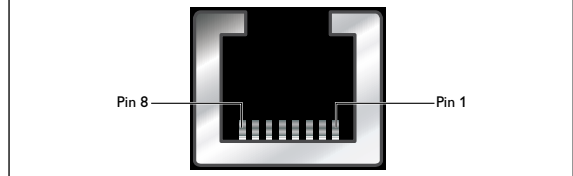

\* Direction relative this unit.

## Ethernet connection TX (2 ports)

(for more details see also page 10)

Position	Direction*	Description
No.1	In/Out	Transmitted/Received data
No. 2	In/Out	Transmitted/Received data
No. 3	In/Out	Transmitted/Received data
No. 4		Not Connected
No. 5		Not Connected
No. 6	In/Out	Transmitted/Received data
No. 7		Not Connected
No. 8		Not Connected

\* Direction relative this unit.

## USB

(for more details see also page 10)

Position	Direction*	Description
No.1	Out	VBUS
No. 2	In/Out	D–
No. 3	In/Out	D+
No. 4	Out	GND
Shield	In/Out	Connected to protective earth

\* Direction relative this unit.

## Power connection

(for more details see also page 9)

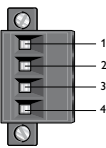
	4-position	Product marking	Direction	Description
	No. 1	+DC1	Input	Supply voltage input DC1
	No. 2	+DC2	Input	Supply voltage input DC2
	No. 3	-COM	Input	Common
	No. 4	-COM	Input	Common

This unit supports redundant power connection. The positive inputs are +DC1 and +DC2, the negative input for both supplies are -COM. Connect the primary voltage (e.g. +24VDC) to the +DC1 pin and return to one of the -COM pins on the power input.

## Console port

(for more details see also page 10)

Position	Direction* / description
No.1	In / out / GND
No. 2	Out / Tx
No. 3	In / Rx

\* Direction relative to this unit.

I/O connection (for details see page 11 and 14)

### Connection to console port

The console port can be used to connect to the CLI (Command Line Interface).

### The following steps needs to be taken

1. Connect the serial diagnostic cable to the console port (use only Westermo cable 1211-2027).
2. Connect cable to your computer (USB port, if drivers are needed they can be downloaded from our Web page).
3. Use a terminal emulator and connect with correct speed and format (115200, 8N1) to the assigned port.

For more information about the CLI, see the WeOS management guide.

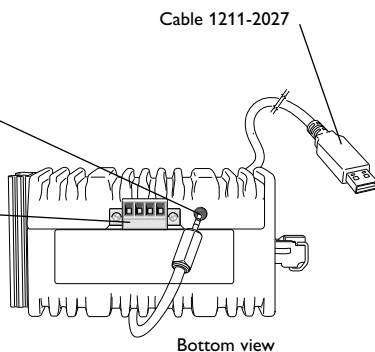

Accessories	
Description	Art no
Westermo console cable	1211-2027
RJ45 to DB9 cable	1211-2210

## SHDSL

	Position	Direction*	Description
	No.1	In/Out	2-wire Receive/Transmit SHDSL
	No. 2	In/Out	2-wire Receive/Transmit SHDSL

\* Direction relative this unit.

## I/O connection

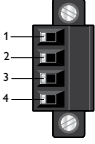
	4-position	Product marking	Direction	Description
	No. 1	Status +	Output	Alarm relay (status) contact
	No. 2	Status -	Output	Alarm relay (status) contact
	No. 3	Digital in +	Input	Digital in +
	No. 4	Digital in -	Input	Digital in -

The Status output is a potential free, opto-isolated normally closed solid-state relay. This can be configured to monitor various alarm events within the unit, see VveOS Management Guide. An external load in series with an external voltage source is required for proper functionality. For voltage/current ratings, see Interface Specification section.

The Digital in is an opto-isolated digital input which can be used to monitor external events. For voltage/current ratings, see Interface Specification section:

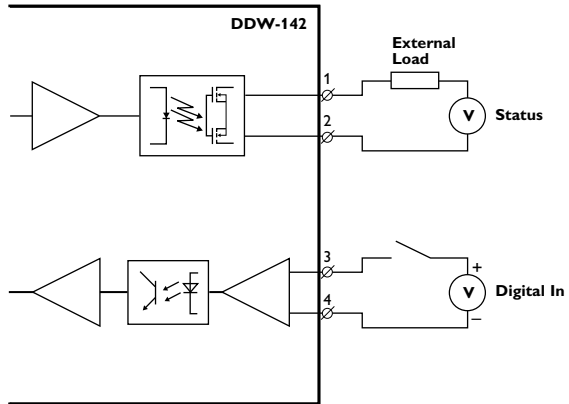

## LED indicators

LED	Status	Description
ON	OFF	Unit has no power.
	GREEN	All OK, no alarm condition.
	RED	Alarm condition, or until unit has started up. (Alarm conditions are configurable, see "WeOS Management Guide").
	FLASH	Location indicator ("Here I am!"). Activated when connected to IPConfig Tool, or upon request from Web or CLI.
DC1	OFF	Unit has no power.
	GREEN	Power OK on DC1.
	RED	Power failure on DC1.
DC2	OFF	Unit has no power.
	GREEN	Power OK on DC2.
	RED	Power failure on DC2.
RSTP	OFF	RSTP disabled.
	GREEN	RSTP enabled.
	BLINK	Unit elected as RSTP/STP root switch.
FRNT	OFF	FRNT disabled.
	GREEN	FRNT OK.
	RED	FRNT Error.
	BLINK	Unit configured as FRNT focal point.
LNK SHDSL ports Link indicator Port 1-2	OFF	No DSL link.
	GREEN	DSL link established.
	GREEN FLASH	DSL link negotiation.
	YELLOW	Port alarm and no link. Or if FRNT or RSTP mode, port is blocked.
SHDSL ports Quality indicator Port 1-2	All OFF	No DSL link.
	3 RED	Signal to noise value below 3 dB. <b>Unstable DSL link.</b>
	1 GREEN	Signal to noise value 3-5 dB. <b>Marginal DSL link.</b>
	2 GREEN	Signal to noise value 6-9 dB. <b>Normal DSL link.</b>
	3 GREEN	Signal to noise value above 9 dB. <b>Strong DSL link.</b>
RD	OFF	No serial data transmitted.
	GREEN FLASH	Serial data transmitted.
TD	OFF	No serial data received.
	GREEN FLASH	Serial data received.
Copper ports Port 1-2	OFF	No link.
	GREEN	Link established.
	GREEN FLASH	Data traffic indication.
	YELLOW	Port alarm and no link. Or if FRNT, RSTP or Link Aggregation mode, port is blocked.

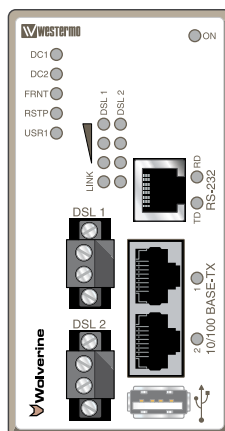

## Mounting

This unit should be mounted on 35 mm DIN-rail, which is horizontally mounted inside an apparatus cabinet or similar. It is recommended that the DIN-rail is connected to ground. Snap on mounting, see figure.

Mounting DDW-142 with integrated DIN-clip:

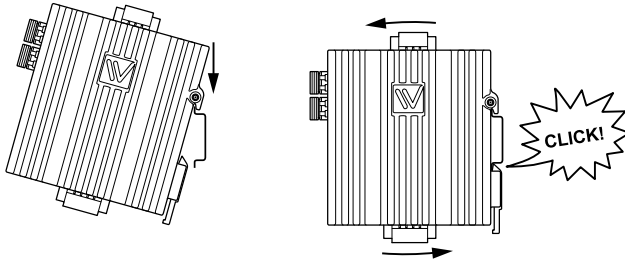

## Removal

Removing DDW-142 with integrated DIN-clip:

Press down the support at the back of the unit using a screwdriver. See figure.

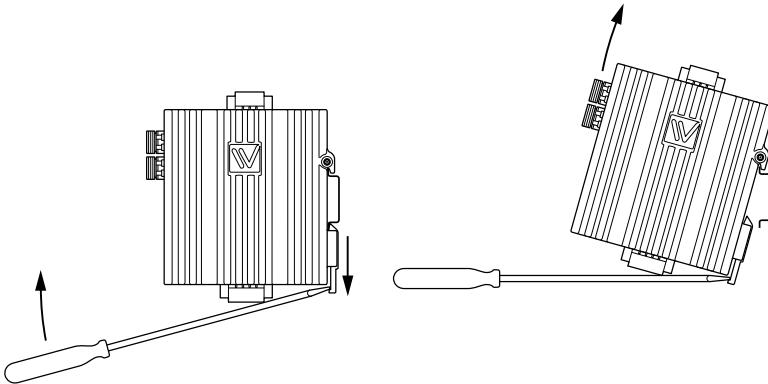

## Cooling

This unit uses convection cooling. To avoid obstructing the airflow around the unit, use the following spacing rules. Minimum spacing 25 mm (1.0 inch) above / below and 10 mm (0.4 inches) left / right the unit. Spacing is recommended for the use of unit in full operating temperature range and service life.

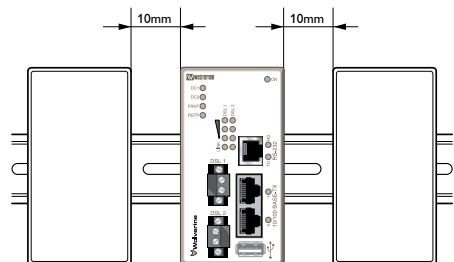

## Getting Started

This product runs Westermo Operating System (WeOS) which provides several management tools that can be used for configuration of the unit.

- **IPConfig tool**  
This is a custom Westermo tool used for discovery of attached Westermo units.
- **Web**  
Configuration of the unit using the web browser.
- **CLI**  
Configuration of the unit via the Command Line Interface.

If the computer is located in the same subnet as the switch you can easily use a web browser to configure the unit. Within the web you can configure most of the available functions.

For advanced network settings and more diagnostic information, please use the CLI. Detailed documentation is available in the chapter "The Command Line Management Tool" in the WeOS management guide.

Factory default	IP address:	192.168.2.200
	Netmask:	255.255.255.0
	Gateway:	Disabled

**Note!** If you are not sure about the subnet – consult your network administrator.

## Configuration

### Configure the unit via web browser

The unit can easily be configured via a web browser.

Open the link <http://192.168.2.200> in your web browser, and you will be prompted with a Login screen, where the default settings for Username and Password are:

*Username:* admin

*Password:* westermo

Once you have logged in, you can use the extensive integrated help function describing all configuration options. Two common task when configuring a new switch is to assign appropriate IP settings, and to change the password of the admin account.

The password can be up to 64 characters long, and should consist of printable ASCII characters (ASCII 33-126); 'Space' is not a valid password character.

## Referring documents

Type	Description	Document number
Management Guide	Westermo OS management guide	6101-3201

### Cable factory reset on DDW-142

It is possible to set the unit to factory default settings by using a standard Ethernet RJ-45 cable.

1. Power off the unit and disconnect all cables.
  2. Connect an Ethernet cable between Ethernet ports 1 and 2.  
The unit needs to be connected directly by an Ethernet cable i.e., not via a hub or switch.  
Use a straight cable – not a cross-over cable, when connecting the ports.
  3. Power on the unit.
  4. Wait for the unit to start-up. Control that the ON LED is flashing red.  
The ON LED flashing indicates that the unit is now ready to be reset to factory default. You now have the choice to go ahead with the factory reset, or to skip factory reset and boot as normal.
    - Go ahead with factory reset:  
Acknowledge that you wish to conduct the factory reset by unplugging the Ethernet cable. The ON LED will stop flashing.  
This initiates the factory reset process\*, and the unit will restart with factory default settings. When the switch has booted up, the ON LED will show a green light, and is now ready to use.
    - Skip the factory reset:  
To skip the factory reset process, just wait for approximately 30 seconds (after the ON LED starts flashing RED) without unplugging the Ethernet cable.  
The switch will conduct a normal boot with the existing settings.
- \* **Note** Do not power off the unit while the factory reset process is in progress.



## Dimensions

Measurements are stated in millimeters.

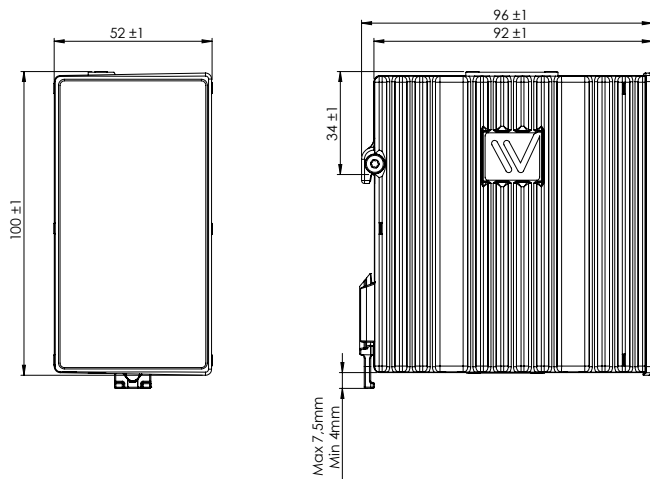







Westermo • SE-640 40 Stora Sundby, Sweden  
Tel +46 16 42 80 00 Fax +46 16 42 80 01  
E-mail: [info@westermo.com](mailto:info@westermo.com)  
[www.westermo.com](http://www.westermo.com)

## Sales Units

### Westermo Data Communications

---

#### China

[sales.cn@westermo.com](mailto:sales.cn@westermo.com)  
[www.cn.westermo.com](http://www.cn.westermo.com)

#### France

[infos@westermo.fr](mailto:infos@westermo.fr)  
[www.westermo.fr](http://www.westermo.fr)

#### Germany

[info@westermo.de](mailto:info@westermo.de)  
[www.westermo.de](http://www.westermo.de)

#### North America

[info@westermo.com](mailto:info@westermo.com)  
[www.westermo.com](http://www.westermo.com)

#### Singapore

[sales@westermo.com.sg](mailto:sales@westermo.com.sg)  
[www.westermo.com](http://www.westermo.com)

#### Sweden

[info.sverige@westermo.se](mailto:info.sverige@westermo.se)  
[www.westermo.se](http://www.westermo.se)

#### United Kingdom

[sales@westermo.co.uk](mailto:sales@westermo.co.uk)  
[www.westermo.co.uk](http://www.westermo.co.uk)

#### Other Offices



*For complete contact information, please visit our website at [www.westermo.com/contact](http://www.westermo.com/contact) or scan the QR code with your mobile phone.*